

DI

SECTION

DRIVER INFORMATION SYSTEM

CONTENTS

<p>PRECAUTION 3</p> <p>Precautions for Supplemental Restraint System (SRS) "AIR BAG" and "SEAT BELT PRE-TENSIONER" 3</p> <p>Wiring Diagrams and Trouble Diagnosis 3</p> <p>COMBINATION METERS 4</p> <p>System Description 4</p> <p>UNIFIED METER CONTROL UNIT 4</p> <p>UNIFIED METER AND A/C AMP. 4</p> <p>HOW TO CHANGE THE DISPLAY FOR ODO/TRIP METER 5</p> <p>POWER SUPPLY AND GROUND CIRCUIT 5</p> <p>WATER TEMPERATURE GAUGE 6</p> <p>TACHOMETER 6</p> <p>FUEL GAUGE 6</p> <p>SPEEDOMETER 6</p> <p>Component Parts and Harness Connector Location... 6</p> <p>Combination Meter 7</p> <p>CHECK 7</p> <p>Circuit Diagram 8</p> <p>Wiring Diagram — METER — 9</p> <p>Terminals and Reference Value for Combination Meter 11</p> <p>Terminals and Reference Value for Unified Meter and A/C Amp. 12</p> <p>Meter/Gauge Operation and Odo/Trip Meter 13</p> <p>SELF-DIAGNOSIS FUNCTION 13</p> <p>HOW TO ALTERNATE DIAGNOSIS MODE 13</p> <p>CONSULT-II Function 13</p> <p>How to Proceed With Trouble Diagnosis 14</p> <p>Diagnosis Flow 14</p> <p>Power Supply and Ground Circuit Inspection 15</p> <p>Symptom Chart 1 17</p> <p>Symptom Chart 2 18</p> <p>Vehicle Speed Signal Inspection 18</p> <p>Engine Speed Signal Inspection 20</p> <p>Water Temperature Signal Inspection 21</p> <p>Fuel Level Sensor Signal Inspection 1 22</p> <p>FUEL GAUGE 22</p> <p>Fuel Level Sensor Signal Inspection 2 23</p>	<p>LOW-FUEL WARNING LAMP 23</p> <p>CAN Communication System Inspection 24</p> <p>Communication Line Inspection 24</p> <p>Odo/Trip Meter and Illumination Control Switch Inspection 26</p> <p>Fuel Gauge Pointer Fluctuates, Indicator Wrong Value or Varies 27</p> <p>Fuel Gauge Does Not Move to FULL position 27</p> <p>Electrical Components Inspection 28</p> <p>CHECK FUEL LEVEL SENSOR UNIT 28</p> <p>Removal and Installation 28</p> <p>COMBINATION METER ASSEMBLY 28</p> <p>Disassembly and Assembly for Combination Meter.. 29</p> <p>DISASSEMBLY 29</p> <p>ASSEMBLY 30</p> <p>Removal and Installation of Odo/Trip Meter and Illumination Control Switch 30</p> <p>REMOVAL 30</p> <p>INSTALLATION 30</p> <p>UNIFIED METER AND A/C AMP 31</p> <p>System Description 31</p> <p>INPUT/OUTPUT SIGNALS 31</p> <p>FAIL-SAFE 32</p> <p>CAN Communication System Description 33</p> <p>CAN Communication Unit 33</p> <p>TYPE 1/TYPE2 34</p> <p>TYPE 3 37</p> <p>TYPE 4/TYPE5 40</p> <p>TYPE 6 43</p> <p>Schematic 47</p> <p>CONSULT-II Function 48</p> <p>CONSULT-II BASIC OPERATION 48</p> <p>SELF-DIAGNOSTIC RESULTS 49</p> <p>DATA MONITOR 49</p> <p>Removal and Installation of Unified Meter and A/C Amp. 51</p> <p>REMOVAL 51</p> <p>INSTALLATION 51</p> <p>COMPASS 52</p> <p>System Description 52</p>
----------------------------------------------------------------------------------------------------------------------------------------------------------------------------------------------------------------------------------------------------------------------------------------------------------------------------------------------------------------------------------------------------------------------------------------------------------------------------------------------------------------------------------------------------------------------------------------------------------------------------------------------------------------------------------------------------------------------------------------------------------------------------------------------------------------------------------------------------------------------------------------------------------------------------------------------------------------------------------------------------------------------------------------------------------------------------------------------------------------------------------------------------------------------------------------------------------------------------------------------------------------------------------------------------------------------------------------------------------------------------------------------------------------------------------------------------------------------------------------------------------------------------------------------------------------------------------------------------------------------------------------	------------------------------------------------------------------------------------------------------------------------------------------------------------------------------------------------------------------------------------------------------------------------------------------------------------------------------------------------------------------------------------------------------------------------------------------------------------------------------------------------------------------------------------------------------------------------------------------------------------------------------------------------------------------------------------------------------------------------------------------------------------------------------------------------------------------------------------------------------------------------------------------------------------------------------------------------------------------------------------------------------------------------------------------------------------------------------------------------------------------------------------------------------------------------------------------------------------------------------------------------------------------------------------------------------------------------------------------------------------------------------------------------------------------------------------------------------------------------------------------------------------------------------------------------

DIRECTION DISPLAY	52	SELF-DIAGNOSTIC RESULTS	98
Wiring Diagram – COMPAS –	54	All Warnings Are Not Operated	99
Removal and Installation of Compass	55	Key Warning Chime and Light Warning Chime Does Not Operate (Seat Belt Warning Chime Does Operate)	100
WARNING LAMPS	56	Key Warning Chime Does Not Operate (Without Intelligent Key)	101
Schematic	56	Key Warning Chime Does Not Operate (With Intelligent Key, When Mechanical Key Is Used)	104
Wiring Diagram — WARN —	57	Key Warning Chime Does Not Operate (With Intelligent Key, When Intelligent Key Is Carried With The Driver)	106
Oil Pressure Warning Lamp Stays Off (Ignition Switch ON)	65	Light Warning Chime Does Not Operate	108
Oil Pressure Warning Lamp Does Not Turn Off (Oil Pressure Is Normal)	66	Seat Belt Warning Chime Does Not Operate	108
Component Inspection	67	CLOCK	110
OIL PRESSURE SWITCH	67	Wiring Diagram — CLOCK —	110
A/T INDICATOR	68	Removal and Installation of Clock	111
Wiring Diagram — AT/IND —	68	REMOVAL	111
A/T Indicator Is Malfunction	70	INSTALLATION	111
WARNING CHIME	72	REAR VIEW MONITOR	112
Component Parts and Harness Connector Location ..	72	System Description	112
System Description	72	POWER SUPPLY AND GROUND	112
FUNCTION	72	AV COMMUNICATION LINE	112
IGNITION KEY WARNING CHIME (WITHOUT INTELLIGENT KEY)	73	REAR VIEW CAMERA OPERATION	112
IGNITION KEY WARNING CHIME (WITH INTELLIGENT KEY)	73	Component Parts and Harness Connector Location ..	113
LIGHT WARNING CHIME	74	Schematic	114
SEAT BELT WARNING CHIME	74	Wiring Diagram — R/VIEW —	115
CAN Communication System Description	75	Terminals and Reference Value for Rear View Camera Control Unit	118
CAN Communication Unit	75	CONSULT-II Function	119
TYPE 1/TYPE 2	76	CONSULT-II BASIC OPERATION	119
TYPE 3	79	WORK SUPPORT	120
TYPE 4/TYPE 5	82	DATA MONITOR	120
TYPE 6	85	Side Distance Guideline Correction	121
Schematic	89	SIDE DISTANCE GUIDELINE CORRECTION PROCEDURE	121
Wiring Diagram — CHIME —	90	Power Supply and Ground Circuit Inspection	123
Terminals and Reference Value for BCM	93	Rear View Is Not Displayed With The A/T Selector Lever In R-position	124
Terminals and Reference Value for Unified Meter and A/C Amp.	94	The Rear View Image Is Distorted	129
Terminals and Reference Value for Combination Meter	95	Removal and Installation of Rear View Camera Control Unit	130
How to Proceed With Trouble Diagnosis	95	REMOVAL	130
Preliminary Check	96	INSTALLATION	130
CHECK POWER SUPPLY AND GROUND CIRCUIT	96	Removal and Installation of Rear View Camera ..	130
CONSULT-II Function	97	REMOVAL	130
DIAGNOSTIC ITEMS DESCRIPTION	97	INSTALLATION	130
CONSULT-II BASIC OPERATION PROCEDURE	97		
DATA MONITOR	98		
ACTIVE TEST	98		

PRECAUTION

PRECAUTION

PPF:00011

Precautions for Supplemental Restraint System (SRS) “AIR BAG” and “SEAT BELT PRE-TENSIONER”

AKS0054B

The Supplemental Restraint System such as “AIR BAG” and “SEAT BELT PRE-TENSIONER”, used along with a front seat belt, helps to reduce the risk or severity of injury to the driver and front passenger for certain types of collision. This system includes seat belt switch inputs and dual stage front air bag modules. The SRS system uses the seat belt switches to determine the front air bag deployment, and may only deploy one front air bag, depending on the severity of a collision and whether the front occupants are belted or unbelted. Information necessary to service the system safely is included in the SRS and SB section of this Service Manual.

WARNING:

- To avoid rendering the SRS inoperative, which could increase the risk of personal injury or death in the event of a collision which would result in air bag inflation, all maintenance must be performed by an authorized NISSAN/INFINITI dealer.
- Improper maintenance, including incorrect removal and installation of the SRS, can lead to personal injury caused by unintentional activation of the system. For removal of Spiral Cable and Air Bag Module, see the SRS section.
- Do not use electrical test equipment on any circuit related to the SRS unless instructed to in this Service Manual. SRS wiring harnesses can be identified by yellow and/or orange harnesses or harness connectors.

Wiring Diagrams and Trouble Diagnosis

AKS0054D

When you read wiring diagrams, refer to the following:

- Refer to [GI-15, "How to Read Wiring Diagrams"](#) .
- Refer to [PG-3, "POWER SUPPLY ROUTING CIRCUIT"](#) for power distribution circuit.

When you perform trouble diagnosis, refer to the following:

- Refer to [GI-11, "HOW TO FOLLOW TEST GROUPS IN TROUBLE DIAGNOSES"](#) .
- Refer to [GI-27, "How to Perform Efficient Diagnosis for an Electrical Incident"](#) .

A
B
C
D
E
F
G
H
I
J
DI
L
M



COMBINATION METERS

COMBINATION METERS

PFP:24814

System Description

AKS005MH

UNIFIED METER CONTROL UNIT

- Speedometer, odo/trip meter, tachometer, fuel gauge and water temperature gauge are controlled by the unified meter control unit, which is built into the combination meter. Unified meter control unit receives signals from unified meter and A/C amp.
- Warning lamp and indicator lamp of combination meter are controlled by signals drawn from the unified meter and A/C amp.
- Digital meter is adopted for odo/trip meter*.
*The record of the odo meter is kept even if the battery cable is disconnected. The record of the trip meter is erased when the battery cable is disconnected.
- Odo/trip meter, A/T indicator and ICC system display segments can be checked in diagnosis mode.
- Meters/gauges can be checked in diagnosis mode.

Illumination Control

The unified meter control unit outputs the odo/trip meter and A/T indicator lighting when the ignition switch is turned on. When the lighting switch is turned on, light on for the combination meter dial, illumination control switch and external lighting are output. In addition, when the lighting switch is turned on, the illumination control switch on the left side of the combination meter can be used to adjust the brightness of each light. The brightness can be adjusted to sixteen different levels: From 0 (no lights) to 15 (maximum). Pressing the illumination control switch will brighten or darken the lights. When the key switch is in the START position, the combination meter dial lighting and illumination control switch lighting are turned off.

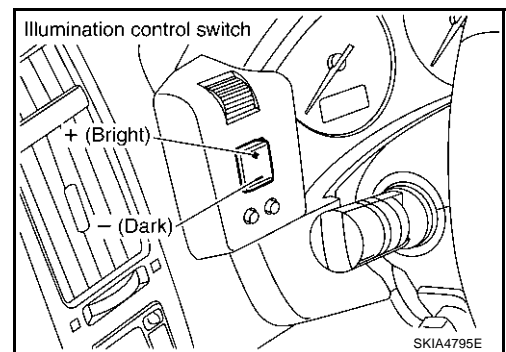

UNIFIED METER AND A/C AMP.

Refer to [DI-31, "System Description"](#) in "UNIFIED METER AND A/C AMP".

COMBINATION METERS

HOW TO CHANGE THE DISPLAY FOR ODO/TRIP METER

- The vehicle speed signal and the memory signals from the meter memory circuit are processed by the combination meter and the mileage is displayed.
- Switch modes with following procedure.

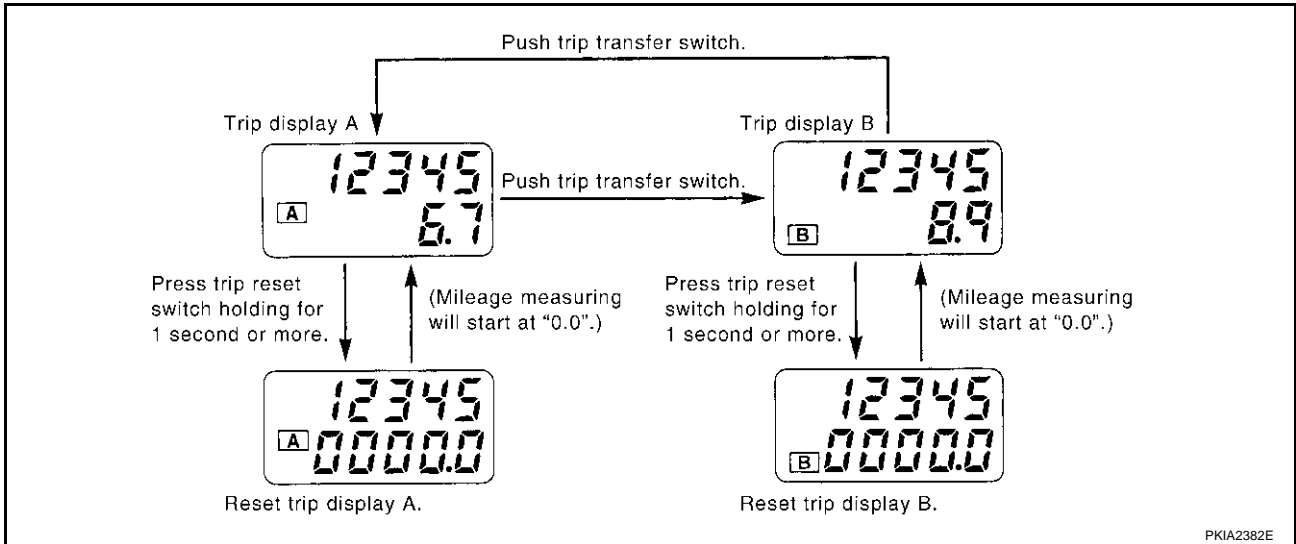

- When trip transfer switch is pressed, trip meter display changes.
- If trip reset switch is pressed for 1 second or more while trip A is displayed, only trip A is reset. (Same with trip B.)
- If the battery is disconnected, odometer mileage will be retained but the trip meter is reset to 0.0.

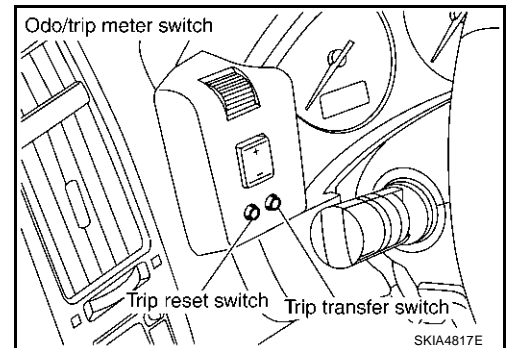

POWER SUPPLY AND GROUND CIRCUIT

Power is supplied at all times

- through 10A fuse [No. 19, located in the fuse block (J/B)]
- to combination meter terminal 8, and
- to unified meter and A/C amp. terminal 21.

With the ignition switch in the ON or START position, power is supplied

- through 10A fuse [No. 14, located in the fuse block (J/B)]
- to combination meter terminal 7
- through 10A fuse [No. 12, located in the fuse block (J/B)]
- to unified meter and A/C amp. terminal 22.

With the ignition switch in the ACC or ON position, power is supplied

- through 15A fuse [No. 10, located in the fuse block (J/B)], and
- through 15A fuse [No. 11, located in the fuse block (J/B)]
- to unified meter and A/C amp. terminal 46.

Ground is supplied

- to combination meter terminals 5, 6 and 15, and
- to unified meter and A/C amp. terminals 29 and 30
- through body grounds M35, M45 and M85.

COMBINATION METERS

WATER TEMPERATURE GAUGE

The water temperature gauge indicates the engine coolant temperature. ECM provides a water temperature signal to unified meter and A/C amp. with CAN communication line. Unified meter and A/C amp. provides a water temperature signal to combination meter for water temperature gauge with communication line between unified meter and A/C amp. and combination meter.

TACHOMETER

The tachometer indicates engine speed in revolutions per minute (rpm). ECM provides an engine speed signal to unified meter and A/C amp. with CAN communication line. Unified meter and A/C amp. provides an engine speed signal to combination meter for tachometer with communication line between unified meter and A/C amp. and combination meter.

FUEL GAUGE

The fuel gauge indicates the approximate fuel level in the fuel tank. The fuel gauge is regulated by a variable ground signal supplied

- from unified meter and A/C amp. terminal 36
- through the fuel level sensor unit and fuel pump (main) terminals 5 and 2, and
- through the fuel level sensor unit (sub) terminals 2 and 1
- to unified meter and A/C amp. terminal 28 for the fuel gauge.

Unified meter and A/C amp. provides an fuel level signal to combination meter for fuel gauge with communication line between unified meter and A/C amp. and combination meter.

SPEEDOMETER

ABS actuator and electric unit (control unit) provides a vehicle speed signal to the unified meter and A/C amp. with CAN communication line. After unified meter and A/C amp. received the vehicle speed signal, it changes the signal to 8 pulse signal and provides the 8 pulse signal to the combination meter for the speedometer.

Component Parts and Harness Connector Location

AKS005MI

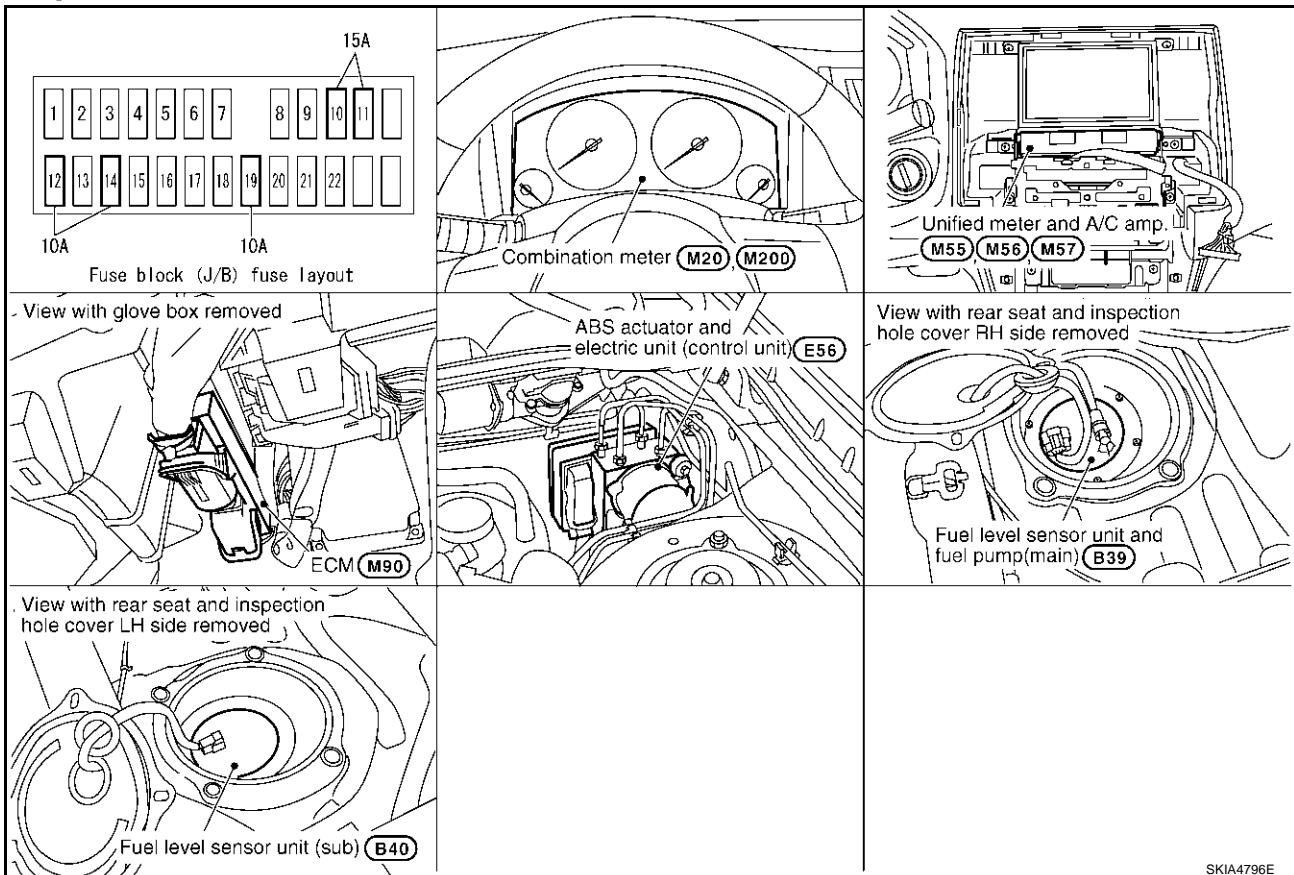

COMBINATION METERS

AKS005MJ

Combination Meter CHECK

A
B
C
D
E
F
G
H
I
J
DI
L
M

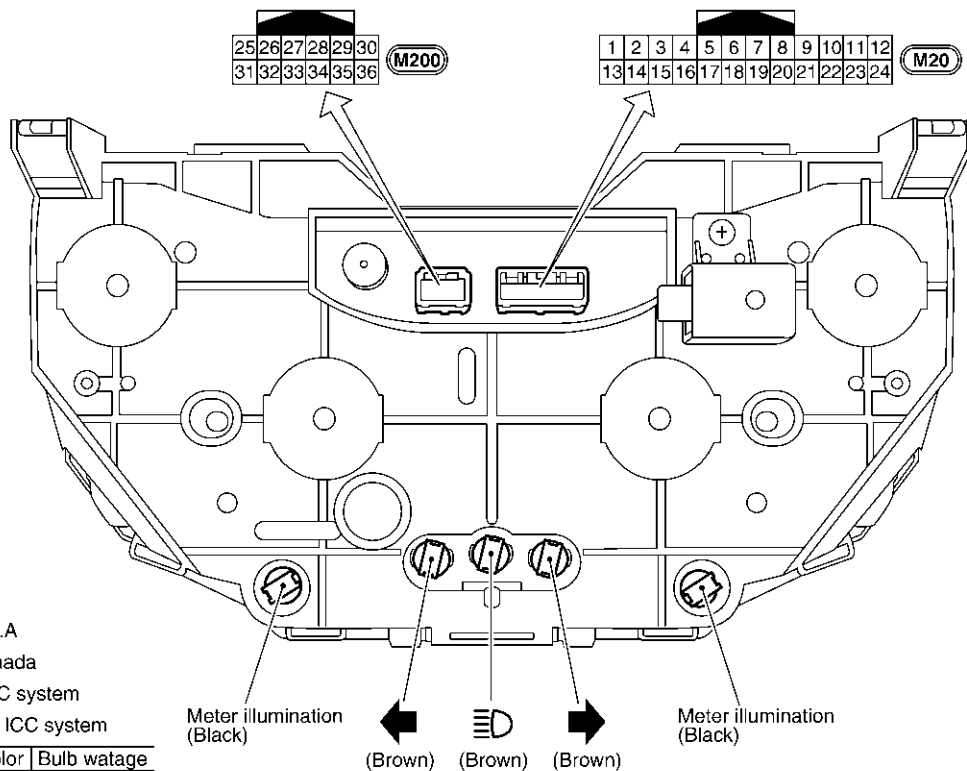
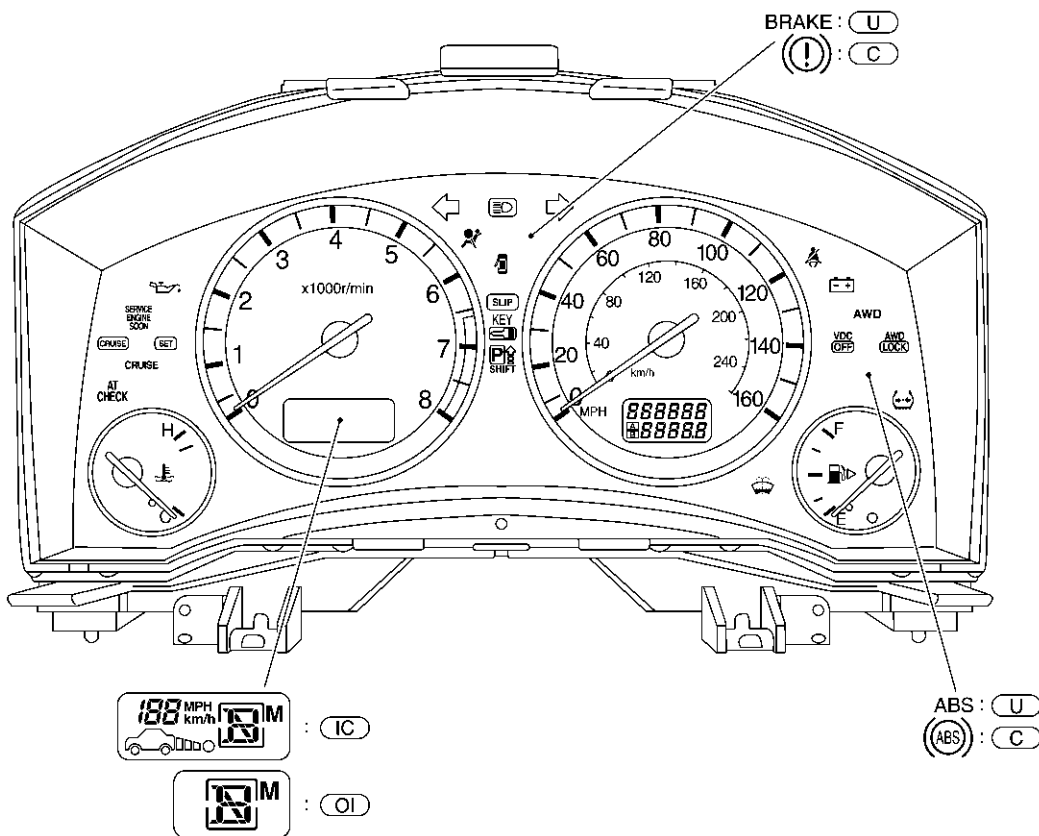

- U : For U.S.A
 - C : For Canada
 - IC : With ICC system
 - OI : Without ICC system
- | Bulb socket color | Bulb wattage |
|-------------------|--------------|
| Brown | 1.4W |
| Black | 3.0W |
- () : Bulb socket color

* THIS CONNECTOR IS NOT SHOW IN "HARNES LAYOUT" , PG SECTION.

SKIA4830E

COMBINATION METERS

Circuit Diagram

AKS005MK

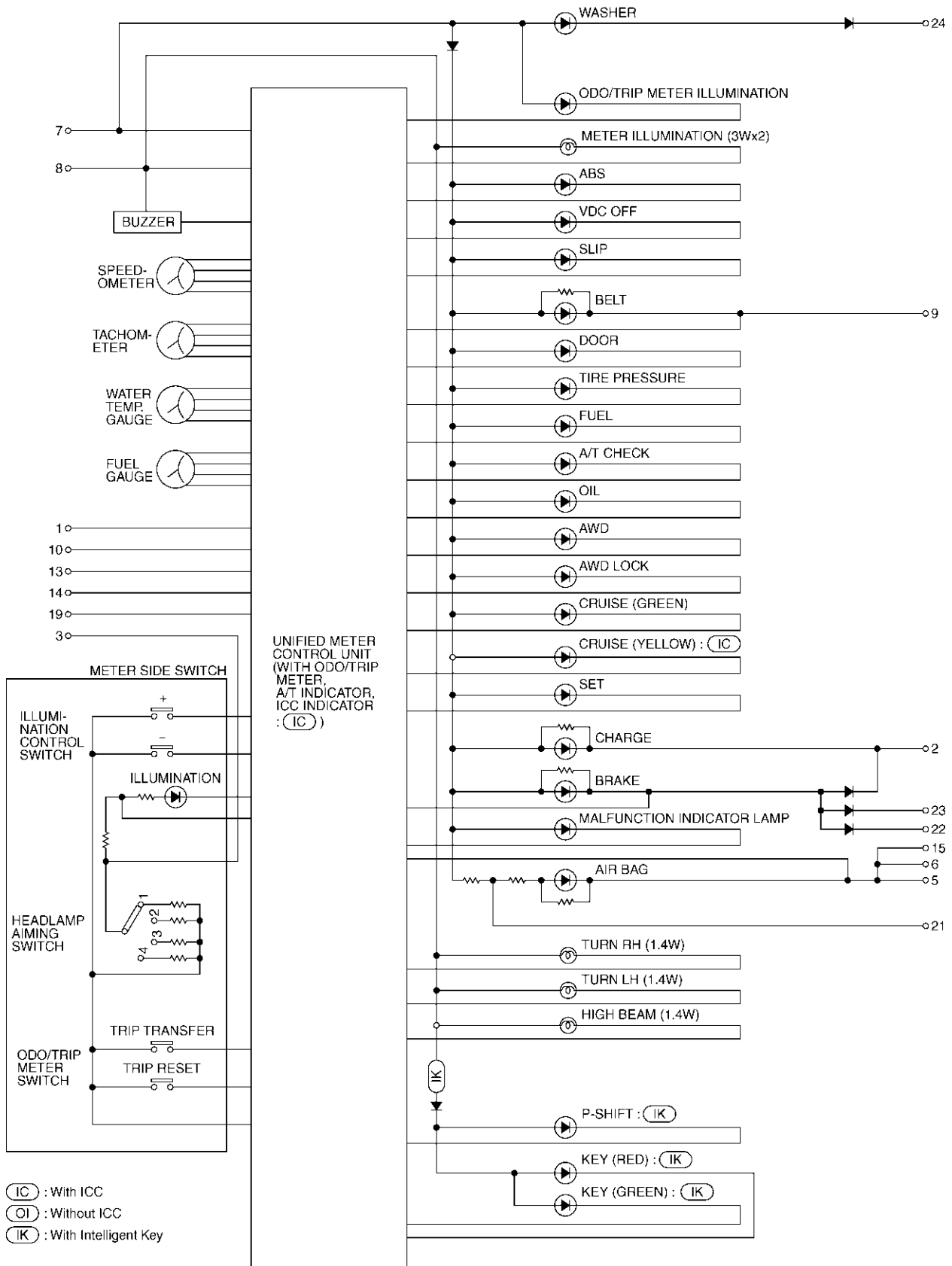

TKWM0680E

COMBINATION METERS

Wiring Diagram — METER —

AKS005ML

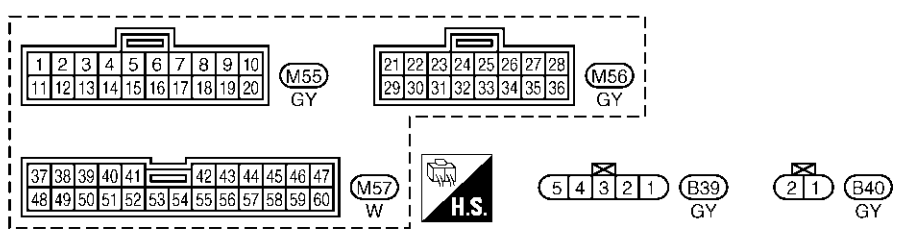
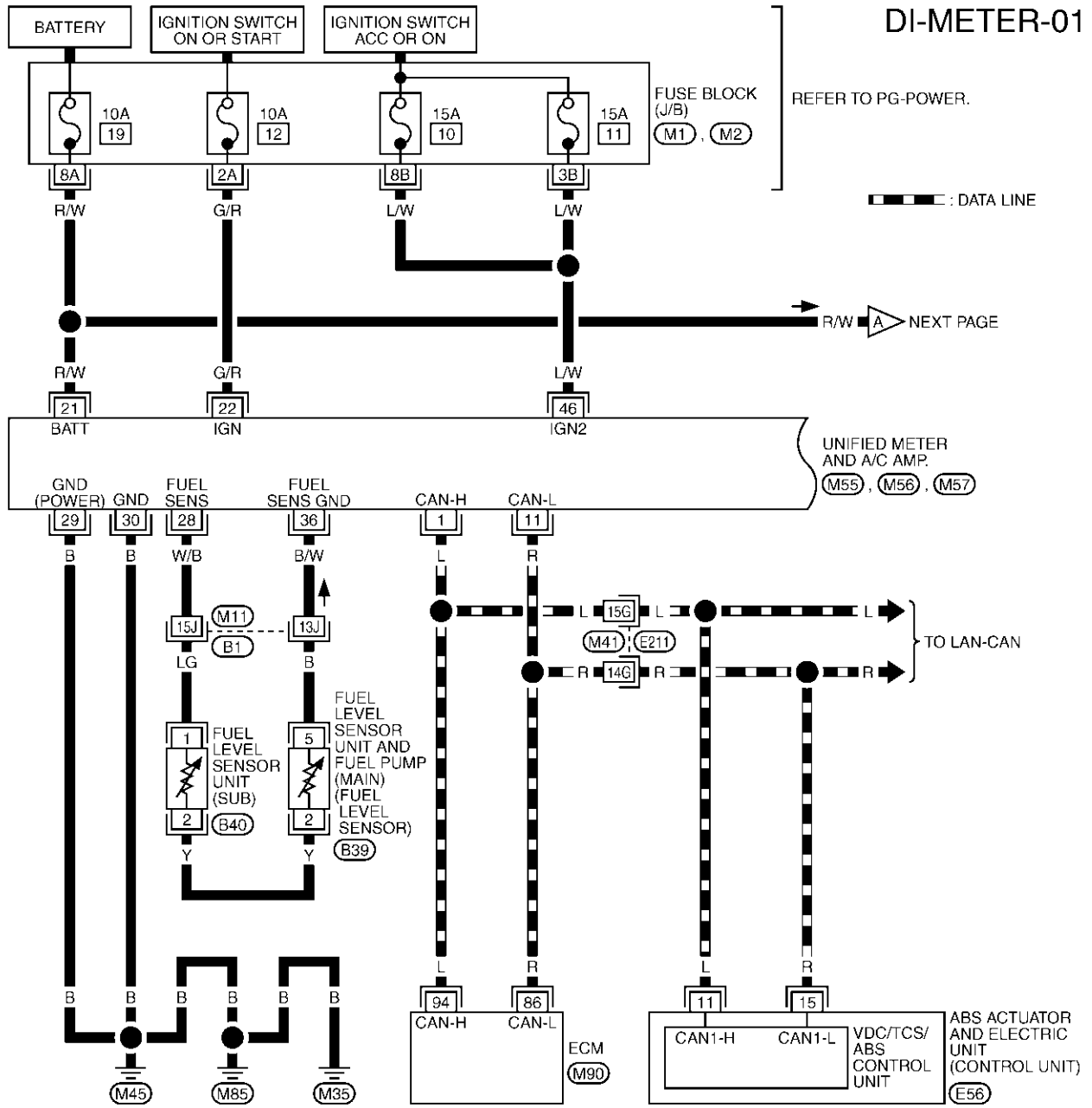

REFER TO THE FOLLOWING.

(E21), (B1) -SUPER MULTIPLE JUNCTION (SMJ)

(M1), (M2) -FUSE BLOCK-JUNCTION BOX (J/B)

(M90), (E56) -ELECTRICAL UNITS

A
B
C
D
E
F
G
H
I
J
DI
L
M

COMBINATION METERS

DI-METER-02

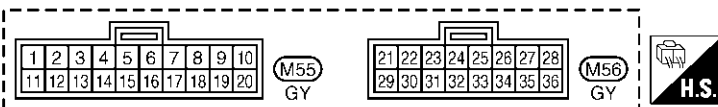
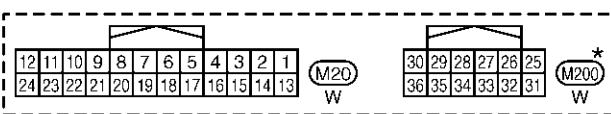
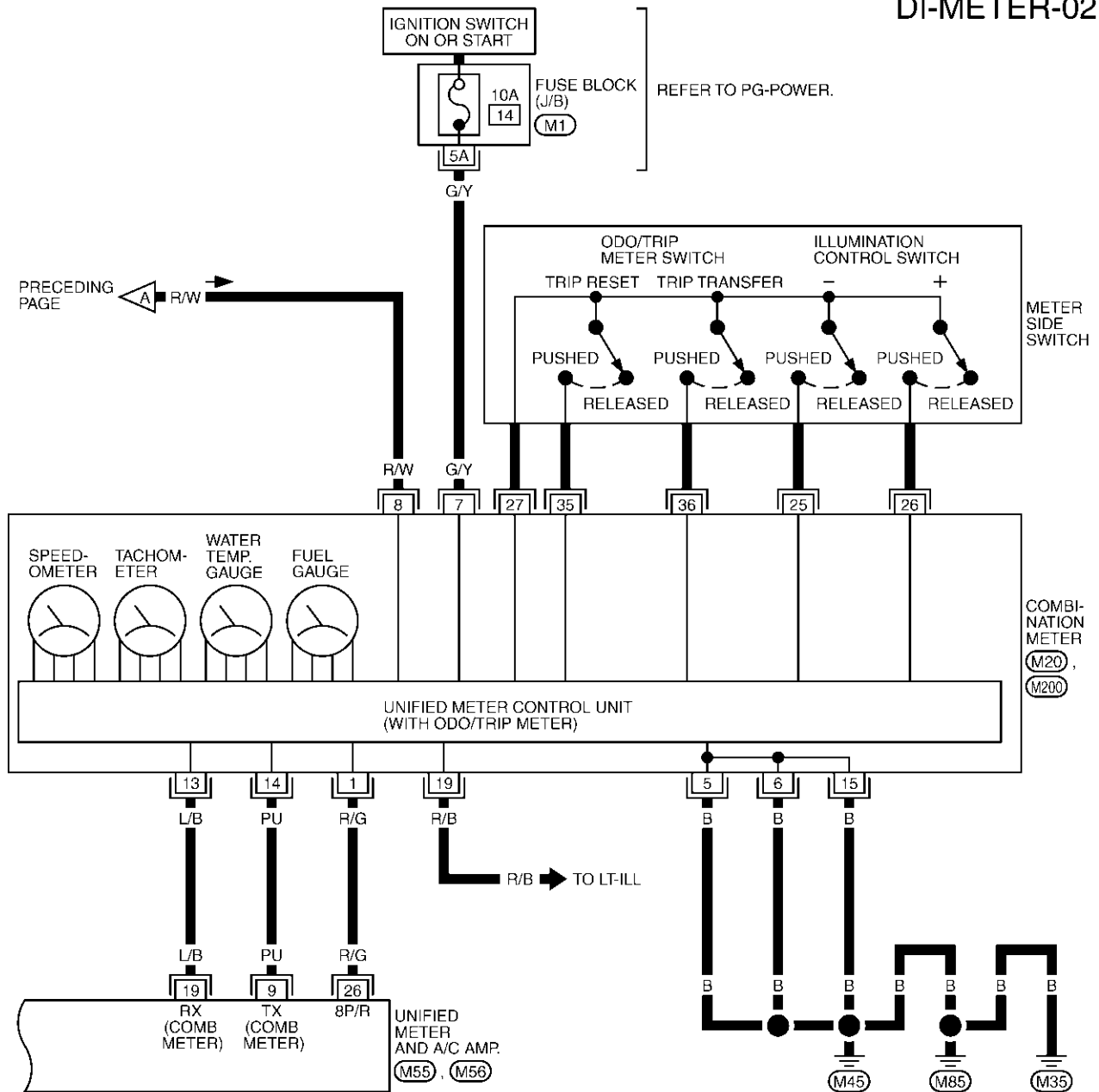

*: THIS CONNECTOR IS NOT SHOWN IN "HARNESS LAYOUT", PG SECTION.

REFER TO THE FOLLOWING.

(M1) - FUSE BLOCK-JUNCTION BOX (J/B)

TKWM0682E

COMBINATION METERS

Terminals and Reference Value for Combination Meter

AKS005MM

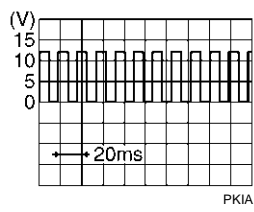
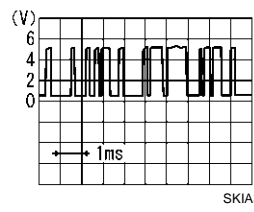
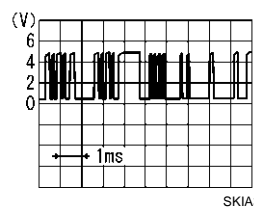
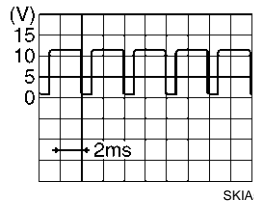
Terminal No.	Wire color	Item	Condition		Reference value
			Ignition switch	Operation or condition	
1	R/G	Vehicle speed signal (8-pulse)	ON	Speedometer operated [When vehicle speed is approx. 40 km/h (25 MPH)]	
5	B	Ground	ON	—	Approx. 0V
6					
7	G/Y	Ignition switch ON or START	ON	—	Battery voltage
8	R/W	Battery power supply	OFF	—	Battery voltage
13	L/B	TX communication line (To unified meter and A/C amp.)	ON	—	
14	PU	RX communication line (From unified meter and A/C amp.)	ON	—	
15	B	Ground	ON	—	Approx. 0V
19	R/B	Illumination signal	ON	Lighting switch ON, then operate the illumination control switch.	<p><e.g.> When brightness level is midway.</p> 
				Lighting switch OFF	Approx. 0V
25	—	Illumination control switch (-)	—	—	<p>Refer to DI-26. "Odo/Trip Meter and Illumination Control Switch Inspection" .</p>
26	—	Illumination control switch (+)	—	—	
27	—	Odo/trip meter and illumination control switch ground	—	—	
35	—	Trip reset switch	—	—	
36	—	Trip transfer switch	—	—	

A
B
C
D
E
F
G
H
I
J
DI
L
M

COMBINATION METERS

Terminals and Reference Value for Unified Meter and A/C Amp.

AKS005MN

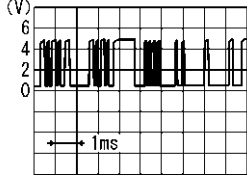
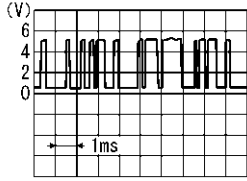
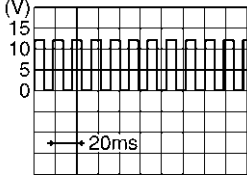
Terminal No.	Wire color	Item	Condition		Reference value
			Ignition switch	Operation or condition	
1	L	CAN H	—	—	—
9	PU	TX communication line (To combination meter)	ON	—	 <p style="text-align: right; font-size: small;">SKIA3362E</p>
11	R	CAN L	—	—	—
19	L/B	RX communication line (From combination meter)	ON	—	 <p style="text-align: right; font-size: small;">SKIA3361E</p>
21	R/W	Battery power supply	OFF	—	Battery voltage
22	G/R	Ignition switch ON or START	ON	—	Battery voltage
26	R/G	Vehicle speed signal (8-pulse)	ON	Speedometer operated [When vehicle speed is approx. 40 km/h (25 MPH)]	 <p style="text-align: right; font-size: small;">PKIA1935E</p>
28	W/B	Fuel level sensor signal	—	—	Refer to DI-28. "CHECK FUEL LEVEL SENSOR UNIT" .
29	B	Ground (for power)	ON	—	Approx. 0V
30	B	Ground	ON	—	Approx. 0V
36	B/W	Fuel level sensor signal ground	ON	—	Approx. 0V
46	L/W	Ignition switch ACC or ON	ACC	—	Battery voltage

COMBINATION METERS

AKS005MO

Meter/Gauge Operation and Odo/Trip Meter SELF-DIAGNOSIS FUNCTION

- Odo/trip meter segment, A/T indicator segment and ICC system display segment operation can be checked in self-diagnosis mode.
- Meters/gauges can be checked in self-diagnosis mode.

HOW TO ALTERNATE DIAGNOSIS MODE

1. Turn ignition switch ON, and switch the odo/trip meter to "trip A" or "trip B".

NOTE:

If the diagnosis function is activated with the trip meter A displayed, the mileage on the trip meter A will indicate 0000.0, but the actual trip mileage will be retained. (Trip B operates the same way.)

2. Turn ignition switch OFF.
3. Turn ignition switch ON while pressing trip transfer switch and trip reset switch at the same time.
4. After ignition switch is turned ON, release trip transfer switch and trip reset switch with 5 seconds.
5. All the segments on the odo/trip meter, A/T indicator and ICC system display illuminates, and simultaneously the low-fuel warning lamp indicator illuminates. At this time, the unified meter control unit is turned to diagnosis mode.

CAUTION:

If any of the segments is not displayed, replace combination meter.

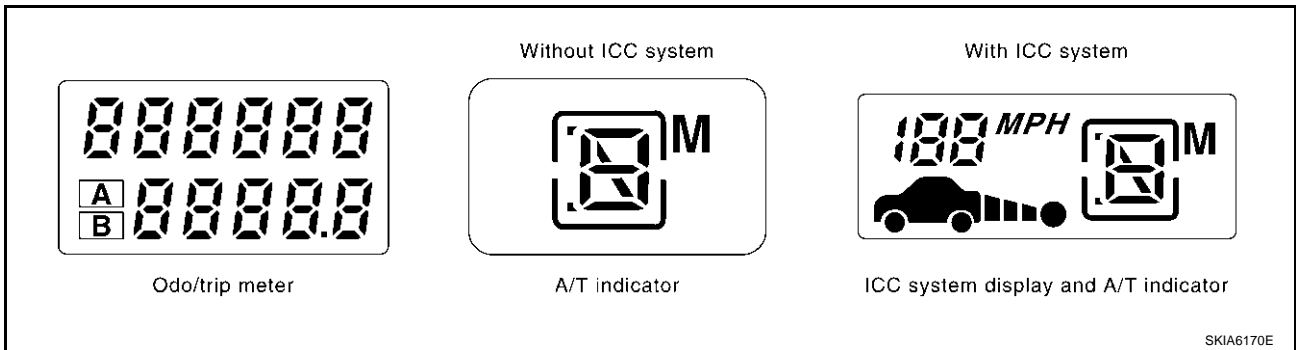
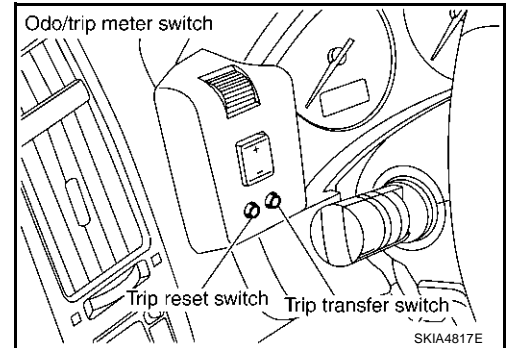

6. Push the odo/trip meter switch. Each meter/gauge should indicate as shown in the figure while pushing odo/trip meter switch. (At this time, the low-fuel warning lamp goes off.)

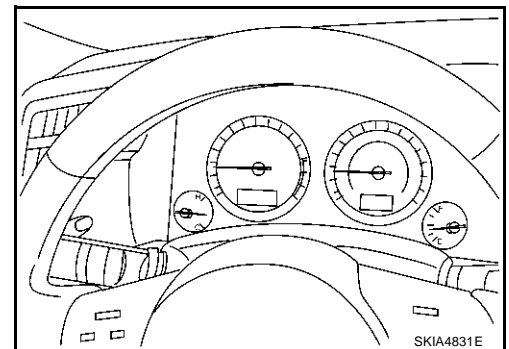

CONSULT-II Function

AKS005MP

Refer to [DI-48, "CONSULT-II Function"](#) in "UNIFIED METER AND A/C AMP".

COMBINATION METERS

AKS005MQ

How to Proceed With Trouble Diagnosis

1. Confirm the symptom or customer complaint.
2. Perform diagnosis according to diagnosis flow. Refer to [DI-14, "Diagnosis Flow"](#) .
3. According to the symptom chart, repair or replace the cause of the symptom.
4. Does the meter operate normally? If so, go to 5. If not, go to 2.
5. INSPECTION END

Diagnosis Flow

AKS005MR

1. CHECK SELF-DIAGNOSTIC RESULTS OF UNIFIED METER AND A/C AMP.

1. Start engine.
2. Select "METER A/C AMP" on CONSULT-II, and perform self-diagnosis of unified meter and A/C amp. Refer to [DI-48, "CONSULT-II Function"](#) .
3. After erasing the self-diagnostic results, perform self-diagnosis again.

Self-diagnostic results content

No malfunction detected >> GO TO 2.

Malfunction detected >> Go to [DI-18, "Symptom Chart 2"](#) .

2. CHECK WARNING LAMP ILLUMINATION

Turn ignition switch ON. (Engine stopped)

Do warning lamps (such as malfunction indicator lamp and oil pressure warning lamp) illuminate?

YES >> GO TO 3.

NO >> Check ignition power supply system of combination meter. Refer to [DI-15, "Power Supply and Ground Circuit Inspection"](#) .

3. CHECK SELF-DIAGNOSIS OPERATION OF COMBINATION METER

Perform combination meter self-diagnosis. Refer to [DI-13, "SELF-DIAGNOSIS FUNCTION"](#) .

Does self-diagnosis function operate?

YES >> GO TO 4.

NO >> Check battery power supply of combination meter and ground system. Refer to [DI-15, "Power Supply and Ground Circuit Inspection"](#) .

4. CHECK ODO/TRIP METER OPERATION

Check odo/trip meter segment, A/T indicator or ICC system display segment.

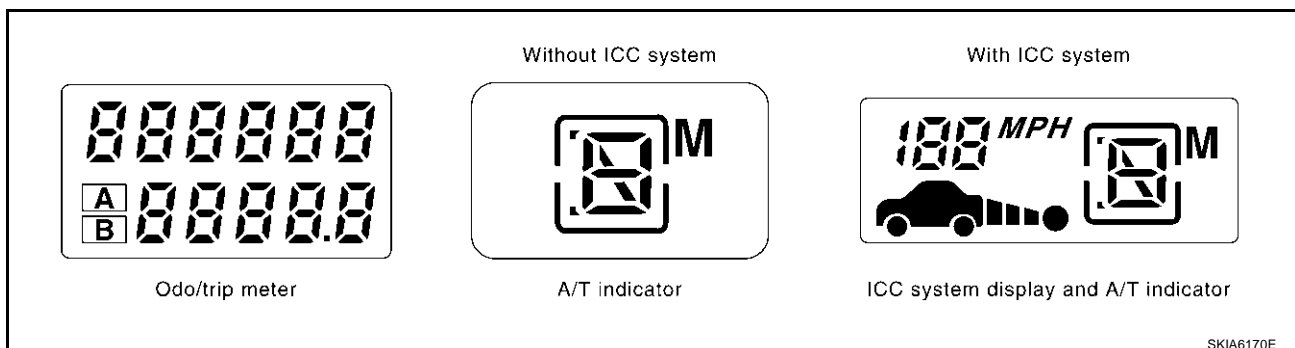

Do all segments illuminate?

YES >> GO TO 5.

NO >> Replace combination meter.

COMBINATION METERS

5. CHECK LOW-FUEL WARNING LAMP ILLUMINATION CONFIRMATION

During low-fuel warning lamp check, confirm illumination of low-fuel warning lamp.

Condition of odo/trip meter switch	Low-fuel warning lamp
Pushed	Does not illuminate.
Released	Illuminates.

OK or NG

- OK >> GO TO 6.
- NG >> Replace combination meter.

6. CHECK COMBINATION METER CIRCUIT

Check indication of each meter/gauge in self-diagnosis mode.

OK or NG

- OK >> Go to [DI-17. "Symptom Chart 1"](#).
- NG >> Replace combination meter.

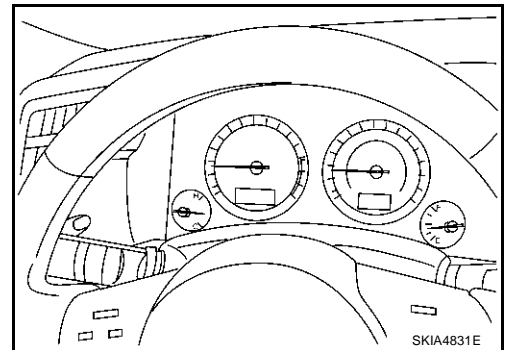

AKS005MS

Power Supply and Ground Circuit Inspection

1. CHECK FUSE

Check for blown combination meter and unified meter and A/C amp. fuses.

Unit	Power source	Fuse No.
Combination meter	Battery	19
Unified meter and A/C amp.		
Combination meter	Ignition switch ON or START	14
Unified meter and A/C amp.	Ignition switch ACC or ON	12
	Ignition switch ON or START	10, 11

Refer to [DI-9. "Wiring Diagram — METER —"](#).

OK or NG

- OK >> GO TO 2.
- NG >> If fuse is blown, be sure to eliminate cause of malfunction before installing new fuse. Refer to [PG-3. "POWER SUPPLY ROUTING CIRCUIT"](#).

COMBINATION METERS

2. CHECK POWER SUPPLY CIRCUIT

1. Disconnect the combination meter connector and the unified meter and A/C amp. connector.
2. Check voltage between combination meter harness connector terminals and ground.

Terminals		Ignition switch position		
(+)		(-)	OFF	ON
Connector	Terminal (Wire color)		Battery voltage	Battery voltage
M20	8 (R/W)	Ground	Battery voltage	Battery voltage
	7 (G/Y)		0V	Battery voltage

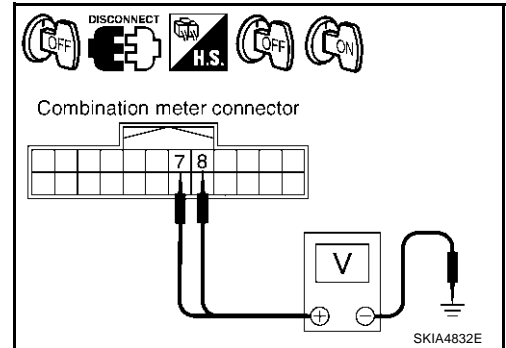

3. Check voltage between unified meter and A/C amp. harness connector terminals and ground.

Terminals		Ignition switch position			
(+)		(-)	OFF	ACC	ON
Connector	Terminal (Wire color)		Battery voltage	Battery voltage	Battery voltage
M56	21 (R/W)	Ground	Battery voltage	Battery voltage	Battery voltage
	22 (G/R)		0V	0V	Battery voltage
M57	46 (L/W)	0V	Battery voltage	Battery voltage	

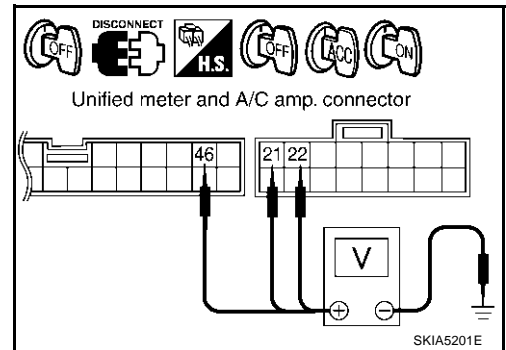

OK or NG

OK >> GO TO 3.

NG >> Check the following.

- Harness for open between combination meter and fuse
- Harness for open between unified meter and A/C amp. and fuse

COMBINATION METERS

3. CHECK GROUND CIRCUIT

1. Turn ignition switch OFF.
2. Check continuity between combination meter harness connector terminals and ground.

Terminals		(-)	Continuity
(+) Connector			
Connector	Terminal (Wire color)		
M20	5 (B)	Ground	Yes
	6 (B)		
	15 (B)		

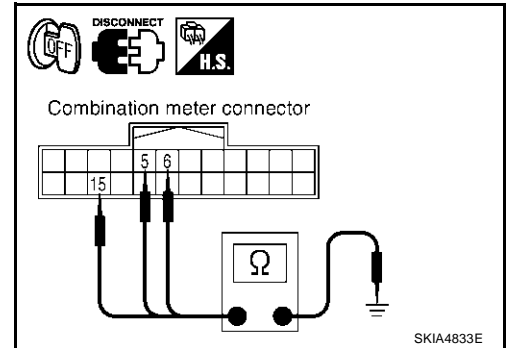

3. Check continuity between unified meter and A/C amp. harness connector terminals and ground.

Terminals		(-)	Continuity
(+) Connector			
Connector	Terminal (Wire color)		
M56	29 (B)	Ground	Yes
	30 (B)		

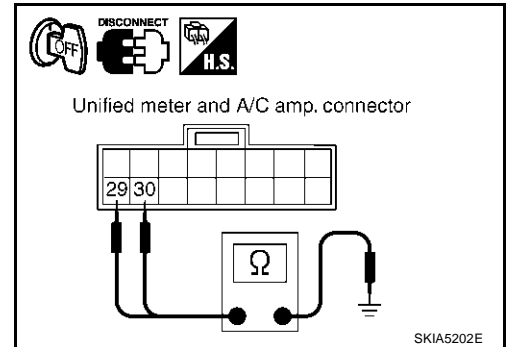

OK or NG

- OK >> INSPECTION END
 NG >> Repair harness or connector.

Symptom Chart 1

AKS005MT

Trouble phenomenon	Possible cause
Indication is irregular for the speedometer and odo/trip meter.	Refer to DI-18, "Vehicle Speed Signal Inspection" .
Tachometer indication is malfunction.	Refer to DI-20, "Engine Speed Signal Inspection" .
Water temperature gauge indication is malfunction.	Refer to DI-21, "Water Temperature Signal Inspection" .
Fuel gauge indication is malfunction.	Refer to DI-22, "Fuel Level Sensor Signal Inspection 1" .
Low-fuel warning lamp indication is irregular.	Refer to DI-23, "Fuel Level Sensor Signal Inspection 2" .
Indications are irregular for more than one gauge.	Replace combination meter.
A/T position indicator is malfunction.	Refer to DI-68, "A/T INDICATOR" .
Illumination control does not operate.	Refer to DI-26, "Odo/Trip Meter and Illumination Control Switch Inspection" .

COMBINATION METERS

Symptom Chart 2

AKS005MU

Displayed item [Code]	Inspection contents	Possible cause
CAN COMM CIRC [U1000]	Inspect the CAN communication.	Refer to DI-24, "CAN Communication System Inspection" . CAUTION: Even when there is no malfunction on CAN communication system, malfunction may be misinterpreted when battery has low voltage (when maintaining 7V-8V for about 2 seconds) or 10A fuse [No. 19, located in the fuse block (J/B)] is disconnected.
METER COMM CIRC [B2202]	Inspect the communication line between combination meter and unified meter and A/C amp.	Refer to DI-24, "Communication Line Inspection" .
VEHICLE SPEED CIRC [B2205]	Inspect the vehicle speed input signal.	<ul style="list-style-type: none"> Perform the ABS actuator and electric unit (control unit) self-diagnosis. Refer to BRC-38, "CONSULT-II Functions" . Replace unified meter and A/C amp. if the above system is normal. CAUTION: Even when there is no malfunction on speed signal system, malfunction may be misinterpreted when battery has low voltage (when maintaining 7V-8V for about 2 seconds).

Vehicle Speed Signal Inspection

AKS005MV

1. CHECK ABS ACTUATOR AND ELECTRIC UNIT (CONTROL UNIT) SELF-DIAGNOSIS

Perform the ABS actuator and electric unit (control unit) self-diagnosis. Refer to [BRC-38, "CONSULT-II Functions"](#) .

OK or NG

- OK >> GO TO 2.
- NG >> Check the applicable parts.

2. CHECK UNIFIED METER AND A/C AMP. OUTPUT SIGNAL

- Start engine and drive vehicle at approximately 40 km/h (25 MPH).
- Check voltage signal between combination meter harness connector M20 terminal 1 (R/G) and ground with simple oscilloscope of CONSULT-II.

1 (R/G) - Ground:

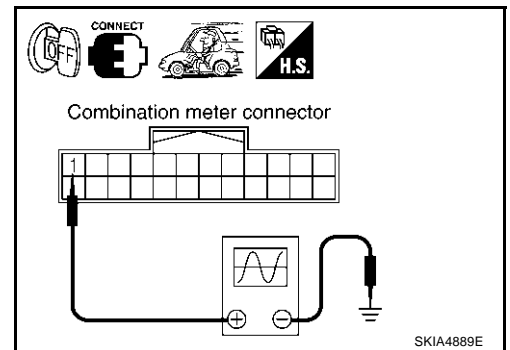
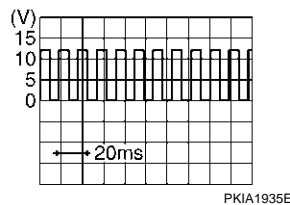

OK or NG

- OK >> Replace combination meter.
- NG >> GO TO 3.

COMBINATION METERS

3. CHECK VOLTAGE OF COMBINATION METER

1. Turn ignition switch OFF.
2. Disconnect unified meter and A/C amp. connector and display control unit connector (with navigation system) or display unit connector (without navigation system).
3. Turn ignition switch ON.
4. Check voltage between combination meter harness connector M20 terminal 1 (R/G) and ground.

Approx. 12V

OK or NG

- OK >> GO TO 4.
NG >> Replace combination meter.

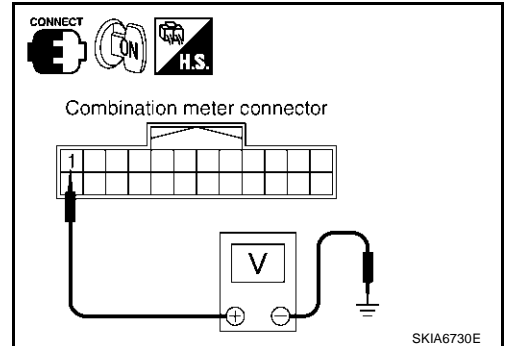

4. CHECK CONTINUITY BETWEEN COMBINATION METER AND UNIFIED METER AND A/C AMP.

1. Disconnect combination meter connector.
2. Check continuity between combination meter harness connector M20 terminal 1 (R/G) and unified meter and A/C amp. harness connector M56 terminal 26 (R/G).

Continuity should exist.

3. Check continuity between combination meter harness connector M20 terminal 1 (R/G) and ground.

Continuity should not exist.

OK or NG

- OK >> Replace unified meter and A/C amp. Refer to [DI-51, "Removal and Installation of Unified Meter and A/C Amp."](#)
- NG >> Repair harness or connector.

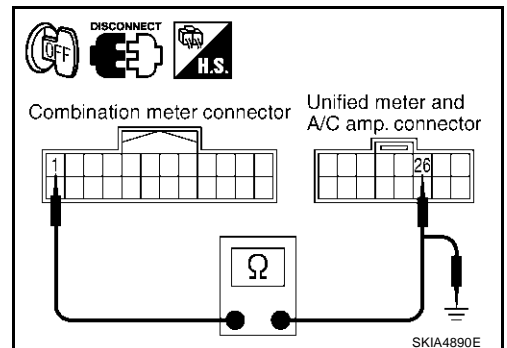

A
B
C
D
E
F
G
H
I
J
DI
L
M

COMBINATION METERS

AKS005MW

Engine Speed Signal Inspection

1. CHECK UNIFIED METER AND A/C AMP. OUTPUT SIGNAL

1. Start an engine and select "METER A/C AMP" on CONSULT-II.
2. Using "TACHO METER" on "DATA MONITOR", compare the value of "DATA MONITOR" with tachometer pointer of combination meter.

OK or NG

- OK >> GO TO 2.
NG >> Replace combination meter.

DATA MONITOR	
MONITOR	
TACHO METER	XXXX rpm

PKIA2090E

2. CHECK UNIFIED METER AND A/C AMP. INPUT SIGNAL

1. Select "ENGINE" on CONSULT-II.
2. Using "ENG SPEED" on "DATA MONITOR", print out the CONSULT-II screen when the engine is idling.
3. Select "METER A/C AMP" on CONSULT-II.
4. Using "TACHO METER" on "DATA MONITOR", compare the value of "DATA MONITOR" of the idling speed with that of the "ENG SPEED".

OK or NG

- OK >> Perform ECM self-diagnosis. Refer to [EC-123, "CONSULT-II Function"](#) (for VQ35DE) or [EC-765, "CONSULT-II Function"](#) (for VK45DE).
- NG >> Replace unified meter and A/C amp. Refer to [DI-51, "Removal and Installation of Unified Meter and A/C Amp."](#)

DATA MONITOR	
MONITOR	
ENG SPEED	XXX rpm

SKIA4367E

COMBINATION METERS

Water Temperature Signal Inspection

AKS005MX

1. CHECK UNIFIED METER AND A/C AMP. INPUT SIGNAL

1. Start engine and select "METER A/C AMP" on CONSULT-II.
2. Using "W TEMP METER" on "DATA MONITOR", compare the value of "DATA MONITOR" with water temperature gauge pointer of combination meter.

Water temperature gauge pointer	Reference value of data monitor °C (°F)
Hot	Approx. 130 (266)
Middle	Approx. 70-105 (158-221)
Cold	Approx. 50 (122)

OK or NG

- OK >> GO TO 2.
 NG >> Replace combination meter.

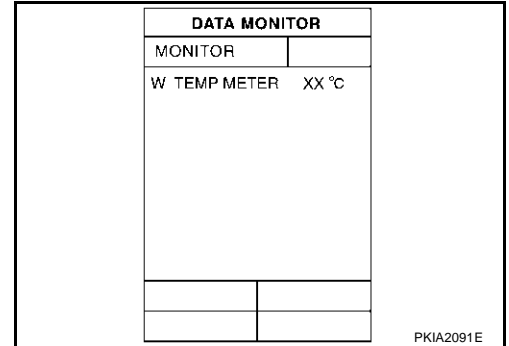

2. CHECK UNIFIED METER AND A/C AMP. INPUT SIGNAL

1. Select "ENGINE" on CONSULT-II.
2. Using "COOLAN TEMP/S" on "DATA MONITOR", print out the CONSULT-II screen.
3. Select "METER A/C AMP" on CONSULT-II.
4. Using "W TEMP METER" on "DATA MONITOR", compare the value of "DATA MONITOR" with that of the "COOLAN TEMP/S".

OK or NG

- OK >> Perform ECM self-diagnosis. Refer to [EC-123, "CONSULT-II Function"](#) (for VQ35DE) or [EC-765, "CONSULT-II Function"](#) (for VK45DE).
- NG >> Replace unified meter and A/C amp. Refer to [DI-51, "Removal and Installation of Unified Meter and A/C Amp."](#)

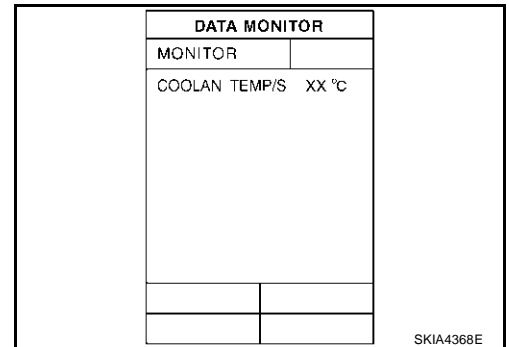

A
B
C
D
E
F
G
H
I
J
L
M

DI

COMBINATION METERS

AKS005MY

Fuel Level Sensor Signal Inspection 1

The following symptoms do not indicate a malfunction.

FUEL GAUGE

- Depending on vehicle position or driving circumstance, the fuel in the tank flows and the pointer may fluctuate.
- If the vehicle is fueled with the ignition switch ON, the pointer will move slowly.

1. CHECK UNIFIED METER AND A/C AMP. INPUT SIGNAL

1. Select "METER A/C AMP" on CONSULT-II.
2. Using "FUEL METER" on "DATA MONIOR", compare the value of "DATA MONITOR" with fuel gauge pointer of combination meter.

Fuel gauge pointer	Reference value of data monitor [lit.]
Full	Approx. 86
Three quarters	Aplox. 70
Half	Approx. 48
A quarter	Approx. 25
Empty	Approx. 9

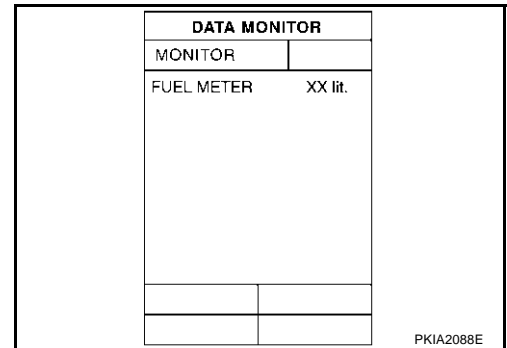

OK or NG

- OK >> GO TO 2.
- NG >> Replace combination meter.

2. CHECK FUEL LEVEL SENSOR

Check components. Refer to [DI-28. "CHECK FUEL LEVEL SENSOR UNIT"](#) .

OK or NG

- OK >> GO TO 3.
- NG >> Replace fuel level sensor unit.

3. CHECK FUEL LEVEL SENSOR (SUB) CIRCUIT

1. Disconnect unified meter and A/C amp. connector and fuel level sensor unit (sub) connector.
2. Check continuity between unified meter and A/C amp. harness connector M56 terminal 28 (W/B) and fuel level sensor unit (sub) harness connector B40 terminal 1 (LG).

Continuity should exist.

3. Check continuity between unified meter and A/C amp. harness connector M56 terminal 28 (W/B) and ground.

Continuity should not exist.

OK or NG

- OK >> GO TO 4.
- NG >> Repair harness or connector.

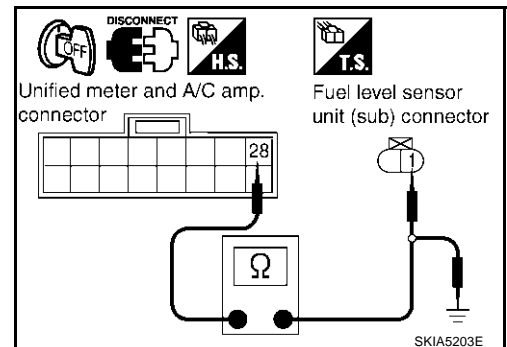

COMBINATION METERS

4. CHECK FUEL LEVEL SENSOR (MAIN-SUB) CIRCUIT

1. Disconnect fuel level sensor unit and fuel pump (main) connector.
2. Check continuity between fuel level sensor unit (sub) harness connector B40 terminal 2 (Y) and fuel level sensor unit and fuel pump (main) harness connector B39 terminal 2 (Y).

Continuity should exist.

3. Check continuity between fuel level sensor unit (sub) harness connector B40 terminal 2 (Y) and ground.

Continuity should not exist.

OK or NG

OK >> GO TO 5.

NG >> Repair harness or connector.

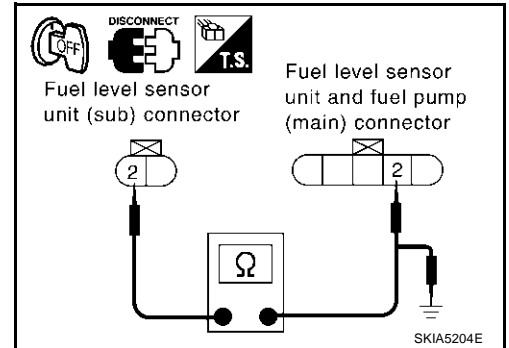

5. CHECK FUEL LEVEL SENSOR (MAIN) CIRCUIT

1. Check continuity between fuel level sensor unit and fuel pump (main) harness connector B39 terminal 5 (B) and unified meter and A/C amp. harness connector M56 terminal 36 (B/W).

Continuity should exist.

2. Check continuity between fuel level sensor unit and fuel pump (main) harness connector B39 terminal 5 (B) and ground.

Continuity should not exist.

OK or NG

OK >> GO TO 6.

NG >> Repair harness or connector.

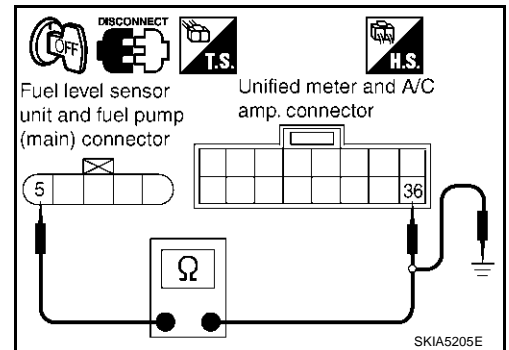

6. CHECK INSTALLATION CONDITION

Check fuel level sensor unit installation, and check whether the float arm interferes or binds with any of the internal components in the fuel tank.

OK or NG

OK >> Replace unified meter and A/C amp. Refer to [DI-51, "Removal and Installation of Unified Meter and A/C Amp."](#).

NG >> Install the fuel level sensor unit properly.

Fuel Level Sensor Signal Inspection 2

AKS005MZ

The following symptoms do not indicate a malfunction.

LOW-FUEL WARNING LAMP

Depending on vehicle position or driving circumstance, the fuel in the tank flows and the warning lamp ON timing may change.

1. CHECK FUEL GAUGE

Check if fuel gauge is normally operating.

YES >> Replace combination meter.

NO >> Go to [DI-22, "Fuel Level Sensor Signal Inspection 1"](#).

COMBINATION METERS

CAN Communication System Inspection

AKS005N0

1. CHECK CAN COMMUNICATION

1. Select "SELF-DIAG RESULTS" mode for "METER A/C AMP" with CONSULT-II.
2. Print out CONSULT-II screen.

>> Go to "CAN system". Refer to [LAN-4, "Precautions When Using CONSULT-II"](#).

Communication Line Inspection

AKS005N1

1. CHECK CONNECTOR

Check combination meter, unified meter and A/C amp. and terminals (combination meter-side, unified meter and A/C amp. side, and harness side) for looseness or bent terminals.

OK or NG

- OK >> GO TO 2.
NG >> Repair terminal or connector.

2. CHECK METER/GAUGES VISUALLY

Does the pointer on the meter/gauge fluctuate at the engine start?

Is the fluctuation acceptable?

- YES >> GO TO 3.
NO >> GO TO 6.

3. CHECK CONTINUITY COMMUNICATION CIRCUIT (TX: COMBINATION METER)

1. Turn ignition switch OFF.
2. Disconnect the combination meter connector and unified meter and A/C amp. connector.
3. Check continuity between combination meter harness connector M20 terminal 13 (L/B) and unified meter and A/C amp. harness connector M55 terminal 19 (L/B).

Continuity should exist.

4. Check continuity between combination meter harness connector M20 terminal 13 (L/B) and ground.

Continuity should not exist.

OK or NG

- OK >> GO TO 4.
NG >> Repair harness or connector.

4. CHECK VOLTAGE OF UNIFIED METER AND A/C AMP.

1. Connect unified meter and A/C amp. connector.
2. Turn ignition switch ON.
3. Check voltage between combination meter harness connector M20 terminal 13 (L/B) and ground.

Approx. 5V

OK or NG

- OK >> GO TO 5.
NG >> Replace unified meter and A/C amp. Refer to [DI-51, "Removal and Installation of Unified Meter and A/C Amp."](#).

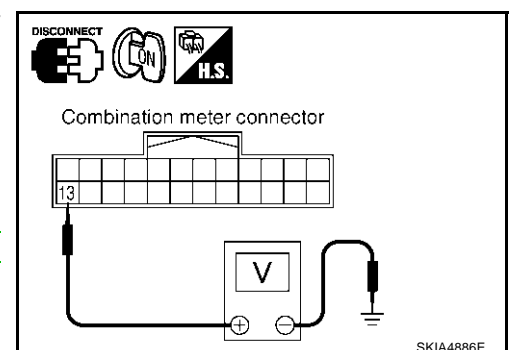
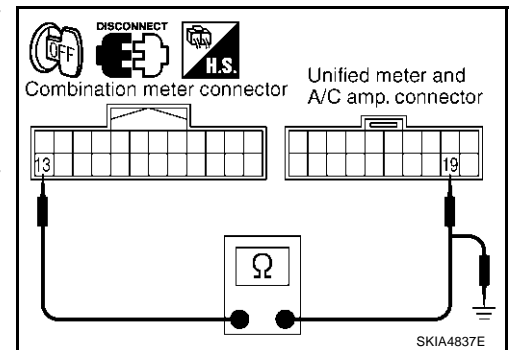

COMBINATION METERS

5. CHECK VOLTAGE SIGNAL OF COMBINATION METER

1. Turn ignition switch OFF and connect combination meter connector.
2. Turn ignition switch ON.
3. Check voltage signal between combination meter harness connector M20 terminal 13 (L/B) and ground with simple oscilloscope of CONSULT-II.

13 (L/B) - Ground:

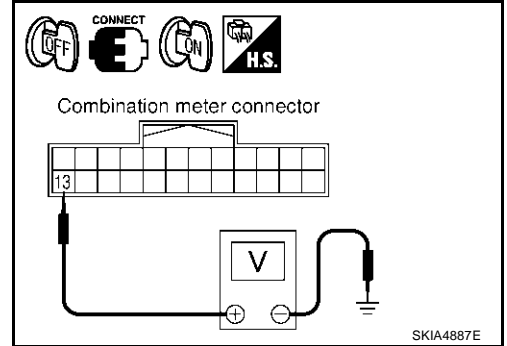
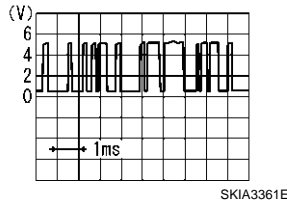

OK or NG

- OK >> Replace unified meter and A/C amp. Refer to [DI-51, "Removal and Installation of Unified Meter and A/C Amp."](#)
- NG >> Replace combination meter.

6. CHECK CONTINUITY COMMUNICATION CIRCUIT (RX: COMBINATION METER)

1. Turn ignition switch OFF.
2. Disconnect combination meter connector and unified meter and A/C amp. connector.
3. Check continuity between combination meter harness connector M20 terminal 14 (PU) and unified meter and A/C amp. harness connector M55 terminal 9 (PU).

Continuity should exist.

4. Check continuity between combination meter harness connector M20 terminal 14 (PU) and ground.

Continuity should not exist.

OK or NG

- OK >> GO TO 7.
- NG >> Repair harness or connector.

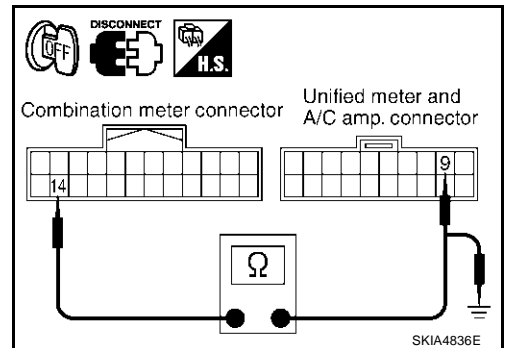

7. CHECK VOLTAGE OF COMBINATION METER

1. Connect combination meter connector.
2. Turn ignition switch ON.
3. Check voltage between unified meter and A/C amp. harness connector M55 terminal 9 (PU) and ground.

Approx. 5V

OK or NG

- OK >> GO TO 8.
- NG >> Replace combination meter.

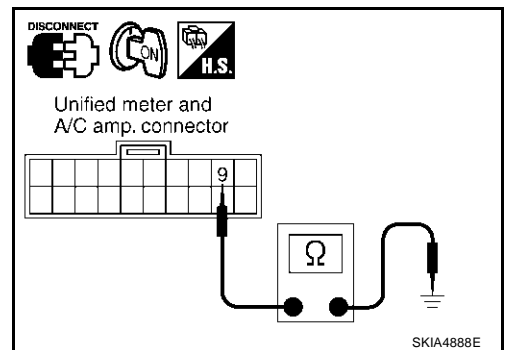

COMBINATION METERS

8. CHECK VOLTAGE SIGNAL OF UNIFIED METER AND A/C AMP.

1. Turn ignition switch OFF and connect unified meter and A/C amp. connector.
2. Turn ignition switch ON.
3. Check voltage signal between combination meter harness connector M20 terminal 14 (PU) and ground with simple oscilloscope of CONSULT-II.

14 (PU) - Ground:

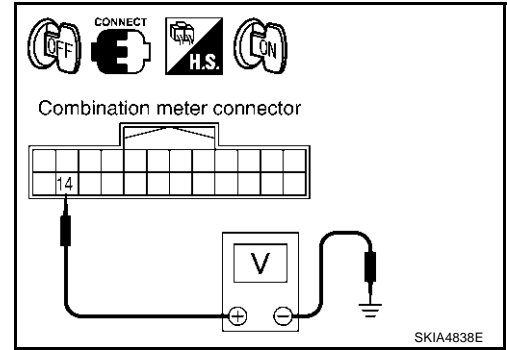
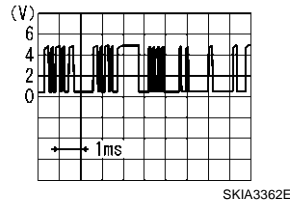

OK or NG

OK >> Replace combination meter.

NG >> Replace unified meter and A/C amp. Refer to [DI-51, "Removal and Installation of Unified Meter and A/C Amp."](#)

Odo/Trip Meter and Illumination Control Switch Inspection

AKS005N2

1. CHECK ODO/TRIP METER AND ILLUMINATION CONTROL SWITCH

1. Remove odo/trip meter and illumination control switch. Refer to [DI-30, "Removal and Installation of Odo/Trip Meter and Illumination Control Switch"](#).
2. Check continuity between odo/trip meter and illumination control switch harness connector terminals 25, 26, 35 or 36 and 27.

Terminal	Condition	Continuity
26	Illumination control switch (+) is pushed.	Yes
	Illumination control switch (+) is released.	No
25	Illumination control switch (-) is pushed.	Yes
	Illumination control switch (-) is released.	No
36	Trip transfer switch is pushed.	Yes
	Trip transfer switch is released.	No
35	Trip reset switch is pushed.	Yes
	Trip reset switch is released.	No

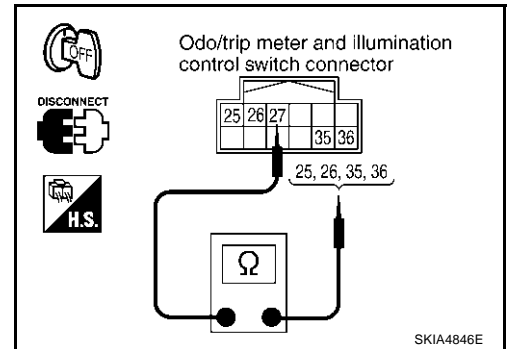

OK or NG

OK >> Replace combination meter.

NG >> Replace odo/trip meter and illumination control switch.

COMBINATION METERS

Fuel Gauge Pointer Fluctuates, Indicator Wrong Value or Varies

AKS005N3

1. CHECK FUEL GAUGE FLUCTUATION

Test drive vehicle to see if gauge fluctuates only during driving or before or after stopping.

Does the indication value vary only during driving or before or after stopping?

- YES >> The pointer fluctuation may be caused by fuel level change in the fuel tank. Condition is normal.
NO >> Ask the customer about the situation when the symptom occurs in detail, and perform the trouble diagnosis.

Fuel Gauge Does Not Move to FULL position

AKS005N4

1. QUESTION 1

Does it take a long time for the pointer to move to FULL position?

- YES >> GO TO 2.
NO >> GO TO 3.

2. QUESTION 2

Was the vehicle fueled with the ignition switch ON?

- YES >> Be sure to fuel the vehicle with the ignition switch OFF. Otherwise, it will take a long time to move to FULL position because of the characteristic of the fuel gauge.
NO >> GO TO 3.

3. QUESTION 3

Is the vehicle parked on an incline?

- YES >> Check the fuel level indication with vehicle on a level surface.
NO >> GO TO 4.

4. QUESTION 4

During driving, does the fuel gauge pointer move gradually toward EMPTY position?

- YES >> Check the fuel level sensor unit. Refer to [DI-28, "CHECK FUEL LEVEL SENSOR UNIT"](#) .
NO >> The float arm may interfere or bind with any of the components in the fuel tank.

A

B

C

D

E

F

G

H

I

J

DI

L

M

COMBINATION METERS

AKS005N5

Electrical Components Inspection CHECK FUEL LEVEL SENSOR UNIT

For removal, refer to [FL-5, "FUEL LEVEL SENSOR UNIT, FUEL FILTER AND FUEL PUMP ASSEMBLY"](#) .

Check Fuel Level Sensor Unit and Fuel Pump (Main)

1. Check the resistance between terminals 2 and 5.

Terminal		Float position		mm (in)	Resistance value Ω
(+)	(-)				
2	5	*1	Empty	29 (1.14)	Approx. 80
		*2	Full	236 (9.29)	Approx. 3

*1 and *2: When float rod is in contact with stopper.

2. If the results of check is NG, check the fuel level sensor unit and fuel pump (main) harness.

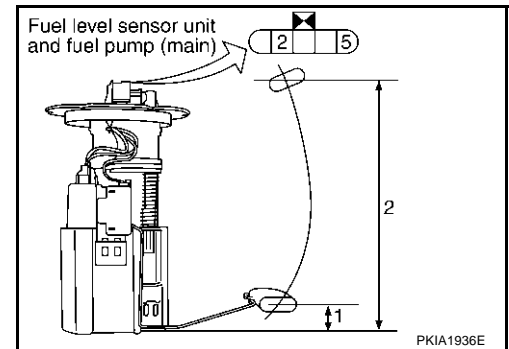

Check Fuel Level Sensor Unit and Pump (Main) Harness

1. Check continuity at following terminals.

Terminal	Continuity
2 - Signal terminal	Yes
5 - Ground terminal	

2. If the results of check is NG, replace fuel pump assembly. If the results of check is OK, replace fuel level sensor unit.

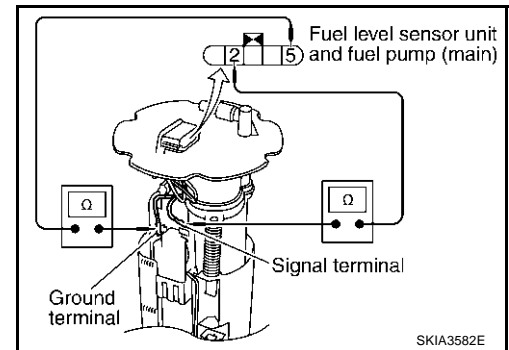

Check Fuel Level Sensor Unit (Sub)

Check resistance between terminals 1 and 2.

Terminal		Float position		mm (in)	Resistance value Ω
(+)	(-)				
1	2	*1	Full	6 (0.24)	Approx. 3
		*2	Empty	203 (7.99)	Approx. 48

*1 and *2: When float rod is in contact with stopper.

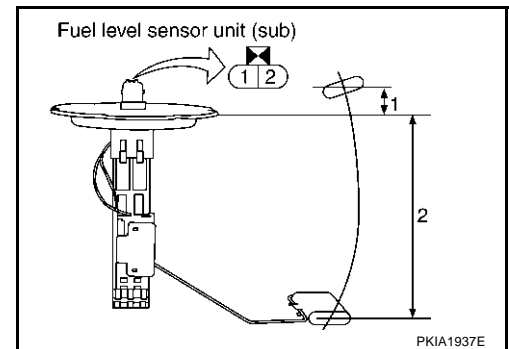

Removal and Installation COMBINATION METER ASSEMBLY

AKS005N6

Refer to [IP-10, "INSTRUMENT PANEL ASSEMBLY"](#) .

COMBINATION METERS

Disassembly and Assembly for Combination Meter

AKS007G1

SEC.248

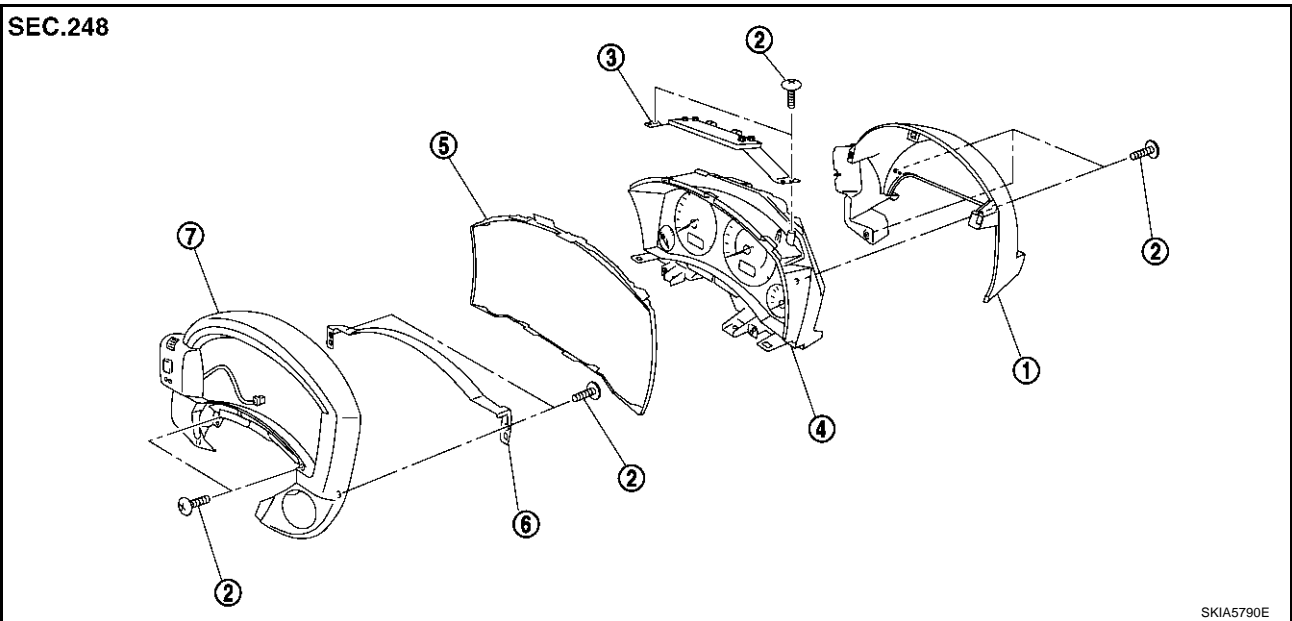

SKIA5790E

- | | | |
|----------------------------------------|----------------|----------------------|
| 1. Rear cover | 2. Screws | 3. Plate |
| 4. Unified meter control unit assembly | 5. Front cover | 6. Reinforcing metal |
| 7. Switch and meter housing | | |

DISASSEMBLY

1. Remove screws (3) and remove rear cover.
2. Disconnect odo/trip meter and illumination control switch connector.

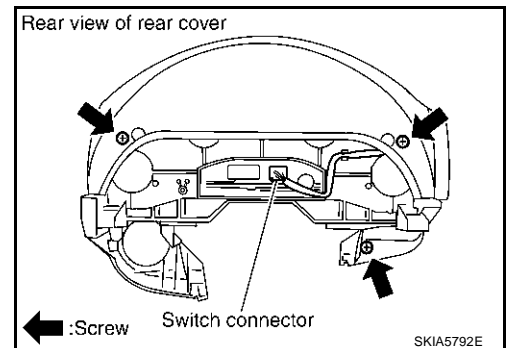

3. Remove screws (2) and remove switch and meter housing.

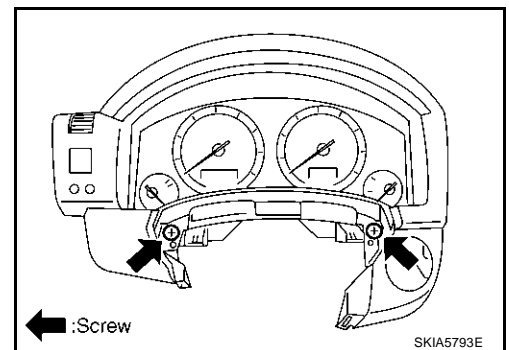

A
B
C
D
E
F
G
H
I
J
DI
L
M

COMBINATION METERS

4. Remove screws (2) and remove reinforcing metal.

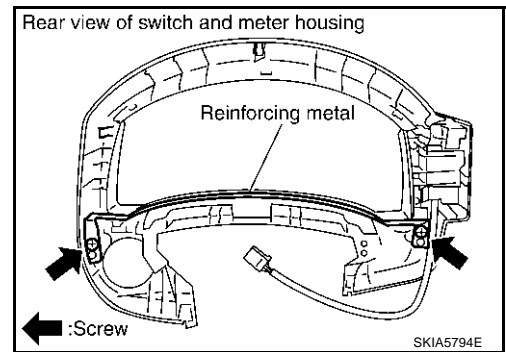

5. Disengage tabs (8) to separate front cover.
6. Remove screws (2) and remove plate.

ASSEMBLY

Assemble in the reverse order of disassembly.

Removal and Installation of Odo/Trip Meter and Illumination Control Switch AKS007G2

REMOVAL

1. Remove combination meter. Refer to [IP-10, "INSTRUMENT PANEL ASSEMBLY"](#).
2. Remove switch and meter housing. Refer to [DI-29, "Disassembly and Assembly for Combination Meter"](#).
3. Remove screws (2), and remove switch assembly.

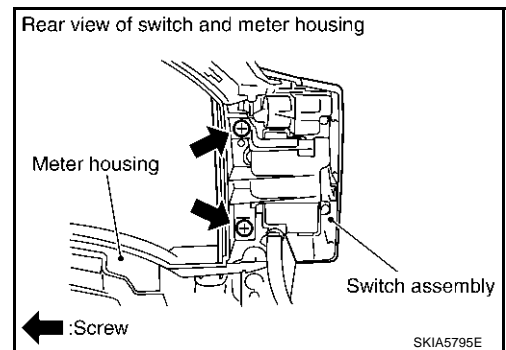

4. Remove screws (5), and remove odo/trip meter and illumination control switch.

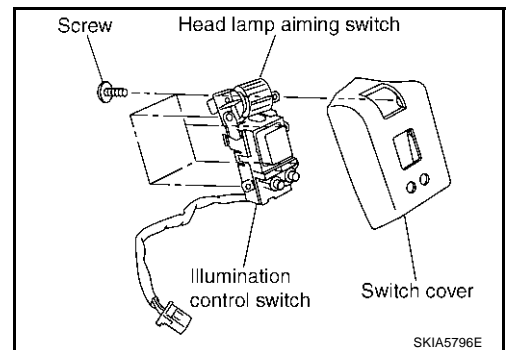

INSTALLATION

Install in the reverse order of removal.

UNIFIED METER AND A/C AMP

UNIFIED METER AND A/C AMP

PF2:27760

System Description

AKS005N8

- For the unified meter and A/C amp., the signal required for controlling the combination meter are integrated in the A/C auto amp.
- Unified meter and A/C amp. controls each operation for A/C auto amp. For information regarding A/C control, refer to [ATC-30, "AIR CONDITIONER CONTROL"](#) in ATC section.
- Unified meter and A/C amp. inputs necessary information for combination meter from each unit by CAN communication and so on.
- And unified meter and A/C amp. outputs these signals using communication line (TX, RX) between unified meter and A/C amp. and combination meter.
- The signals required for the distance to empty (DTE) display are centralized in the unified meter and A/C amp., converted into data, and sent to the display unit (without NAVI) display control unit (with NAVI) using CAN communication.
- Other input signals are also sent to the ECM, TCM, AWD control unit, BCM, display unit (without NAVI) and display control unit (with NAVI) using CAN communication.
- The unified meter and A/C amp. have a CONSULT-II function (self-diagnostic results, CAN diagnostic support monitor, data monitor).

INPUT/OUTPUT SIGNALS

Between Unified Meter and A/C amp. and Combination Meter

Unit	Input	Output
Unified meter and A/C amp.	<ul style="list-style-type: none"> ● Seat belt buckle switch signal (Driver's side) ● Parking brake signal ● Illumination control nighttime required signal ● Refuel status signal ● Low-fuel warning lamp condition signal ● Combination meter receive error signal ● Delivery destination data signal ● Combination meter specifications signal 	<ul style="list-style-type: none"> ● Vehicle speed signal (8-pulse) ● Engine speed signal ● Engine coolant temperature signal ● Fuel level sensor signal (resistance value) ● Malfunction indicator lamp signal ● ABS warning lamp signal ● Low tire pressure warning lamp signal ● Brake warning lamp signal ● AWD warning lamp signal ● A/T CHECK warning lamp signal ● High beam request signal ● Turn indicator signal ● VDC OFF indicator lamp signal ● SLIP indicator lamp signal ● ASCD CRUISE indicator lamp signal ● ASCD SET indicator lamp signal ● ICC warning lamp signal ● ICC system display signal ● AWD LOCK indicator lamp signal ● A/T position indicator signal ● Manual mode indicator signal ● Manual mode gear position signal ● CAN communication condition signal of A/T ● Door switch signal ● Oil pressure switch signal ● Position lights request signal ● Buzzer output signal

UNIFIED METER AND A/C AMP

FAIL-SAFE

Solution When Communication Error Between the Unified Meter & A/C Amp. and the Combination Meter

Function		Specifications
Speedometer		Reset to zero by suspending communication.
Tachometer		
Fuel gauge		
Water temperature gauge		
Illumination control	Combination meter illumination	When suspending communication, change to nighttime mode.
Odo/trip meter		Integrate in response to 8-pulse input.
A/T position indicator		The display turns off by suspending communication.
Warning buzzer		The warning buzzer turns off by suspending communication.
Warning lamp/indicator lamp	ABS warning lamp	The lamp turns on by suspending communication.
	VDC OFF indicator	
	SLIP indicator	
	Brake warning lamp	
	Door warning lamp	The lamp turns off by suspending communication.
	Low tire pressure warning lamp	
	ASCD SET indicator lamp	
	ASCD CRUISE indicator lamp	
	AWD warning lamp	
	AWD LOCK indicator lamp	
	Oil pressure warning lamp	
	Turn signal indicator	
	Malfunction indicator lamp	
	High beam indicator	

UNIFIED METER AND A/C AMP

CAN Communication System Description

AKS007Z1

CAN (Controller Area Network) is a serial communication line for real time application. It is an on-vehicle multiplex communication line with high data communication speed and excellent error detection ability. Many electronic control units are equipped onto a vehicle, and each control unit shares information and links with other control units during operation (not independent). In CAN communication, control units are connected with 2 communication lines (CAN H line, CAN L line) allowing a high rate of information transmission with less wiring. Each control unit transmits/receives data but selectively reads required data only.

CAN Communication Unit

AKS007YX

Body type	Wagon					
Axle	2WD			AWD		
Engine	VQ35DE			VQ35DE/VK45DE		
Transmission	A/T					
Brake control	VDC					
Navigation system			×			×
Low tire pressure warning system			×			×
ICC system			×			×
Intelligent Key system			×			×
Automatic drive positioner		×	×		×	×
CAN communication unit						
ECM	×	×	×	×	×	×
TCM	×	×	×	×	×	×
Display unit	×	×		×	×	
Display control unit			×			×
Low tire pressure warning control unit			×			×
AWD control unit				×	×	×
ICC unit			×			×
Intelligent Key unit			×			×
Data link connector	×	×	×	×	×	×
BCM	×	×	×	×	×	×
Steering angle sensor	×	×	×	×	×	×
Unified meter and A/C amp.	×	×	×	×	×	×
ICC sensor			×			×
ABS actuator and electric unit (control unit)	×	×	×	×	×	×
Driver seat control unit		×	×		×	×
IPDM E/R	×	×	×	×	×	×
CAN communication type	DI-34. "TYPE 1/TYPE2"		DI-37. "TYPE 3"	DI-40. "TYPE 4/TYPE5"		DI-43. "TYPE 6"

×: Applicable

A
B
C
D
E
F
G
H
I
J
DI
L
M

UNIFIED METER AND A/C AMP

TYPE 1/TYPER2

System Diagram

- Type1

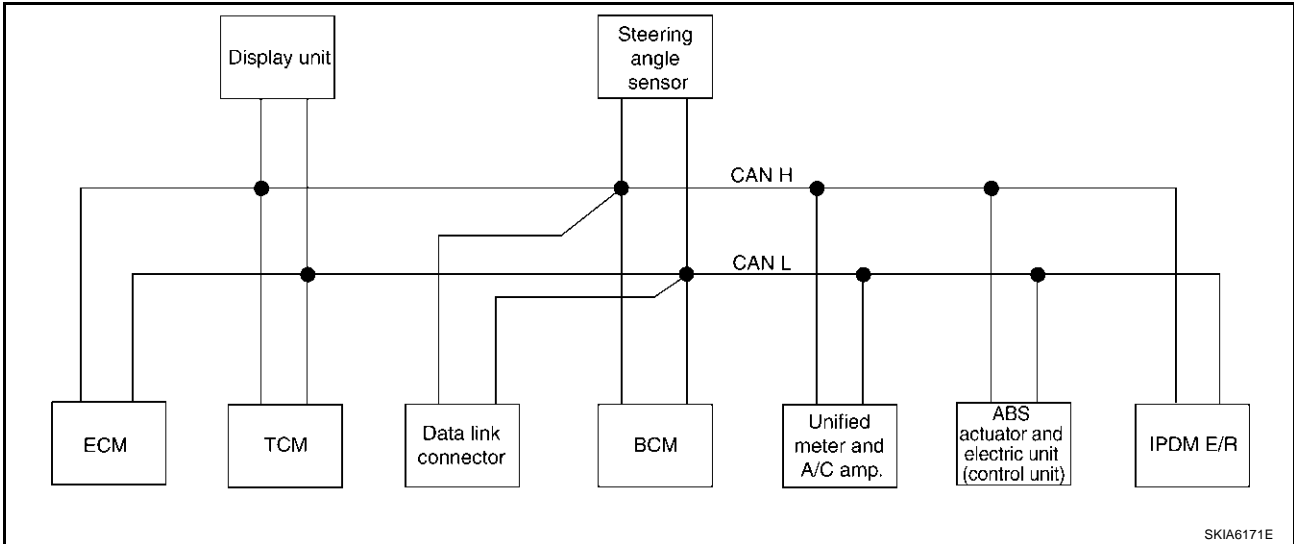

- Type2

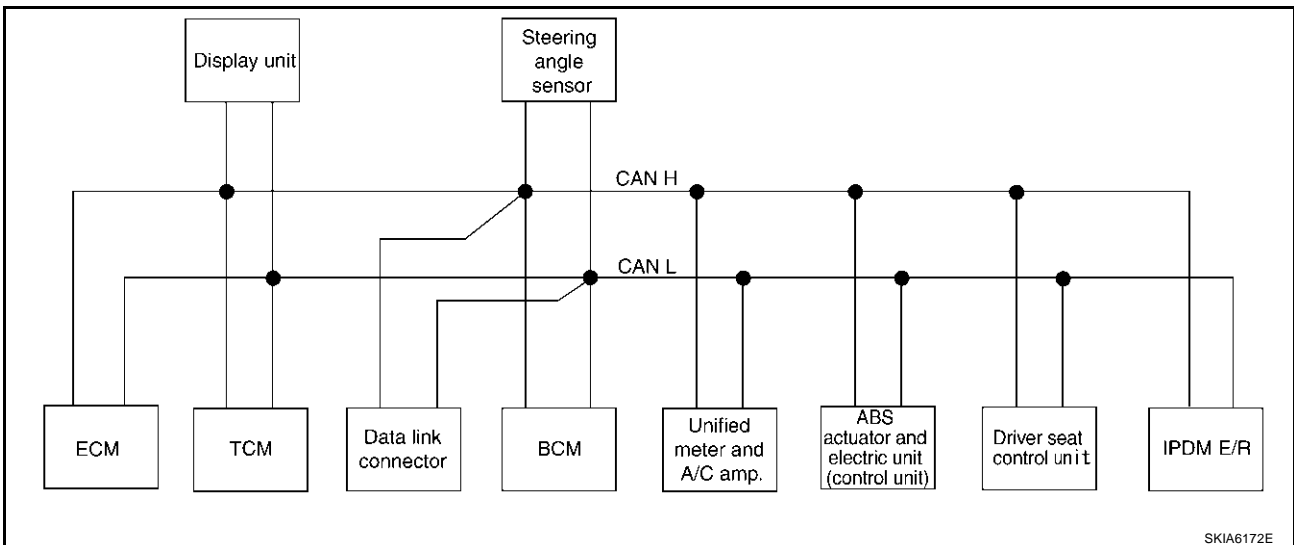

Input/output Signal Chart

T: Transmit R: Receive

Signals	ECM	TCM	Display unit	BCM	Steering angle sensor	Unified meter and A/C amp.	ABS actuator and electric unit (control unit)	Driver seat control unit	IPDM E/R
Engine speed signal	T	R	R			R	R		
Engine status signal	T			R					
Engine coolant temperature signal	T	R				R			
A/T self-diagnosis signal	R	T							
Accelerator pedal position signal	T	R					R		
Closed throttle position signal	T	R							
Wide open throttle position signal	T	R							

UNIFIED METER AND A/C AMP

Signals	ECM	TCM	Display unit	BCM	Steering angle sensor	Unified meter and A/C amp.	ABS actuator and electric unit (control unit)	Driver seat control unit	IPDM E/R
Battery voltage signal	T	R							
Key switch signal				T				R	
Ignition switch signal				T				R	R
P range signal		T					R	R	
Stop lamp switch signal		R				T			
ABS operation signal	R						T		
TCS operation signal	R						T		
VDC operation signal	R						T		
Fuel consumption monitor signal	T		R			R			
Input shaft revolution signal	R	T							
Output shaft revolution signal	R	T							
A/C switch signal	R			T					
A/C compressor request signal	T								R
A/C relay status signal	R								T
A/C compressor feedback signal	T					R			
Blower fan motor switch signal	R			T					
A/C control signal			T			R			
			R			T			
Cooling fan speed request signal	T								R
Cooling fan speed signal	R								T
Position light request signal			R	T		R			R
Low beam request signal				T					R
Low beam status signal	R								T
High beam request signal				T		R			R
High beam status signal	R								T
Front fog light request signal				T					R
Day time running light request signal				T		R			
Turn LED burnout status signal				R		T			
Vehicle speed signal						R	T		
	R	R	R	R		T		R	
Sleep wake up signal				T		R		R	R
Door switch signal			R	T		R		R	R
Turn indicator signal				T		R			
Key fob ID signal				T				R	
Key fob door unlock signal				T				R	
Oil pressure switch signal				R					T
				T		R			
Buzzer output signal				T		R			
Fuel level sensor signal	R					T			
Fuel level low warning signal			R			T			

A
B
C
D
E
F
G
H
I
J
DI
L
M

UNIFIED METER AND A/C AMP

Signals	ECM	TCM	Display unit	BCM	Steering angle sensor	Unified meter and A/C amp.	ABS actuator and electric unit (control unit)	Driver seat control unit	IPDM E/R
ASCD operation signal	T	R							
ASCD OD cancel request	T	R							
Front wiper request signal				T					R
Front wiper stop position signal				R					T
Rear window defogger switch signal				T					R
Rear window defogger control signal	R		R	R					T
Hood switch signal				R					T
Theft warning horn request signal				T					R
Horn chirp signal				T					R
Steering angle sensor signal					T		R		
ABS warning lamp signal						R	T		
VDC OFF indicator lamp signal						R	T		
SLIP indicator lamp signal						R	T		
Brake warning lamp signal						R	T		
System setting signal			T	R				R	
A/T CHECK indicator lamp signal		T				R			
A/T position indicator lamp signal		T				R			
A/T shift schedule change demand signal		R					T		
Manual mode signal		R				T			
Not manual mode signal		R				T			
Manual mode shift up signal		R				T			
Manual mode shift down signal		R				T			
Manual mode indicator signal		T				R			
Distance to empty signal			R			T			
Hand brake switch				R		T			

UNIFIED METER AND A/C AMP

TYPE 3

System Diagram

- Type3

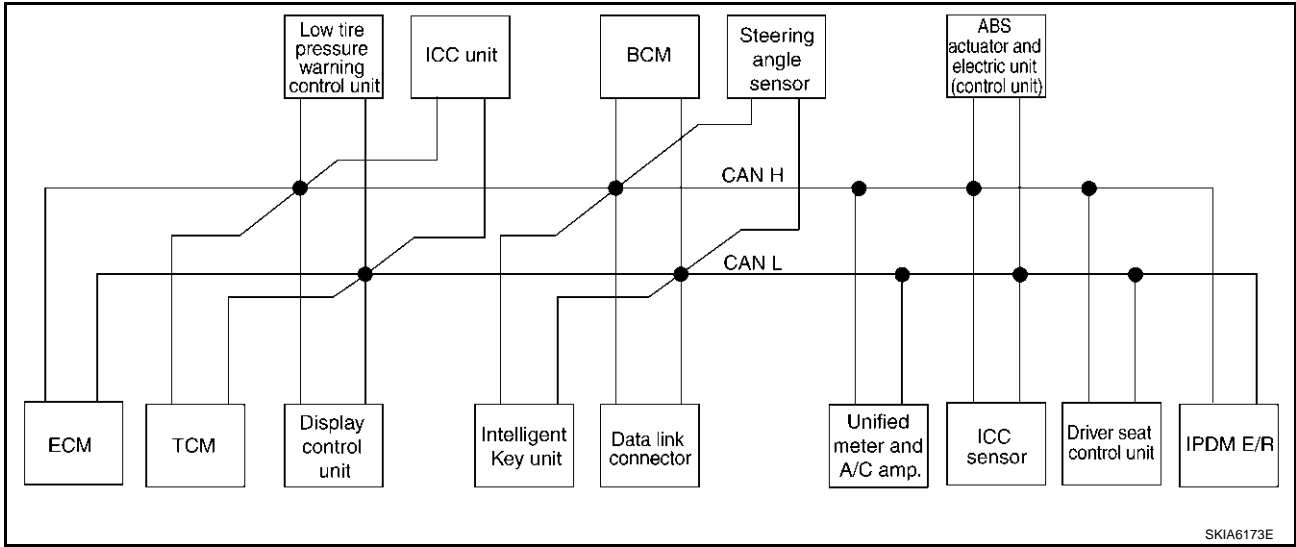

Input/output Signal Chart

T: Transmit R: Receive

Signals	ECM	TCM	Display control unit	Low tire pressure warning control unit	ICC unit	Intelligent Key unit	BCM	Steering angle sensor	Unified meter and A/C amp.	ICC sensor	ABS actuator and electric unit (control unit)	Driver seat control unit	IPDM E/R
Engine speed signal	T	R	R		R				R		R		
Engine status signal	T						R						
Engine coolant temperature signal	T	R			R				R				
A/T self-diagnosis signal	R	T											
Accelerator pedal position signal	T	R			R						R		
Closed throttle position signal	T	R			R								
Wide open throttle position signal	T	R											
Battery voltage signal	T	R											
Key switch signal							T					R	
Ignition switch signal							T					R	R
P range signal		T			R						R	R	
Stop lamp switch signal		R							T				
ABS operation signal	R				R						T		
TCS operation signal	R				R						T		
VDC operation signal	R				R						T		
Fuel consumption monitor signal	T		R						R				

UNIFIED METER AND A/C AMP

Signals	ECM	TCM	Display control unit	Low tire pressure warning control unit	ICC unit	Intelligent Key unit	BCM	Steering angle sensor	Unified meter and A/C amp.	ICC sensor	ABS actuator and electric unit (control unit)	Driver seat control unit	IPDM E/R
Input shaft revolution signal	R	T			R								
Output shaft revolution signal	R	T			R								
A/C switch signal	R						T						
A/C compressor request signal	T												R
A/C relay status signal	R												T
A/C compressor feedback signal	T								R				
Blower fan motor switch signal	R						T						
A/C control signal			T						R				
			R						T				
Cooling fan speed signal	R												T
Position light request signal	R						T		R				R
Low beam request signal							T						R
Low beam status signal	R												T
High beam request signal							T		R				R
High beam status signal	R												T
Front fog light request signal							T						R
Day time running light request signal							T		R				
Turn LED burnout status signal							R		T				
Vehicle speed signal					R				R		T		
	R	R	R	R		R	R		T	R		R	
Sleep wake up signal							T		R			R	R
						T	R						
Door switch signal			R			R	T		R			R	R
Turn indicator signal							T		R				
Key fob ID signal							T					R	
Key fob door unlock signal							T					R	
Oil pressure switch signal							R						T
							T		R				
Buzzer output signal							T		R				
						T			R				
					T				R				

UNIFIED METER AND A/C AMP

Signals	ECM	TCM	Display control unit	Low tire pressure warning control unit	ICC unit	Intelligent Key unit	BCM	Steering angle sensor	Unified meter and A/C amp.	ICC sensor	ABS actuator and electric unit (control unit)	Driver seat control unit	IPDM E/R
Fuel level sensor signal	R								T				
Fuel level low warning signal			R						T				
ICC operation signal	R				T								
Front wiper request signal					R		T						R
Front wiper stop position signal							R						T
Rear window defogger switch signal							T						R
Rear window defogger control signal	R		R				R						T
Hood switch signal							R						T
Theft warning horn request signal							T						R
Horn chirp signal							T						R
Steering angle sensor signal								T			R		
Tire pressure signal				T					R				
Tire pressure data signal			R	T									
ABS warning lamp signal					R				R		T		
VDC OFF indicator lamp signal					R				R		T		
SLIP indicator lamp signal									R		T		
Brake warning lamp signal									R		T		
System setting signal			T			R						R	
Distance to empty signal			R						T				
Hand brake switch signal							R		T				
Door lock/unlock request signal						T	R						
Door lock/unlock status signal						R	T						
Starter permission signal						T	R						
Back door open request signal						T	R						
Power window open request signal						T	R						
Alarm request signal						T	R						
Key warning signal						T			R				
ICC sensor signal					R					T			
ICC warning lamp signal					T				R				

A
B
C
D
E
F
G
H
I
J
DI
L
M

UNIFIED METER AND A/C AMP

Signals	ECM	TCM	Display control unit	Low tire pressure warning control unit	ICC unit	Intelligent Key unit	BCM	Steering angle sensor	Unified meter and A/C amp.	ICC sensor	ABS actuator and electric unit (control unit)	Driver seat control unit	IPDM E/R
ICC system display signal					T				R				
Current gear position signal		T			R						R		
Steering switch signal	T				R								
ASCD operation signal	T	R											
ASCD OD cancel request	T	R											
ICC OD cancel request	R	R			T								
A/T CHECK indicator lamp signal		T							R				
A/T position indicator lamp signal		T							R				
A/T shift schedule change demand signal		R									T		
Manual mode signal		R							T				
Not manual mode signal		R							T				
Manual mode shift up signal		R							T				
Manual mode shift down signal		R							T				
Manual mode indicator signal		T			R				R				
Ignition knob switch signal						T	R						

TYPE 4/TYP5

System Diagram

- Type4

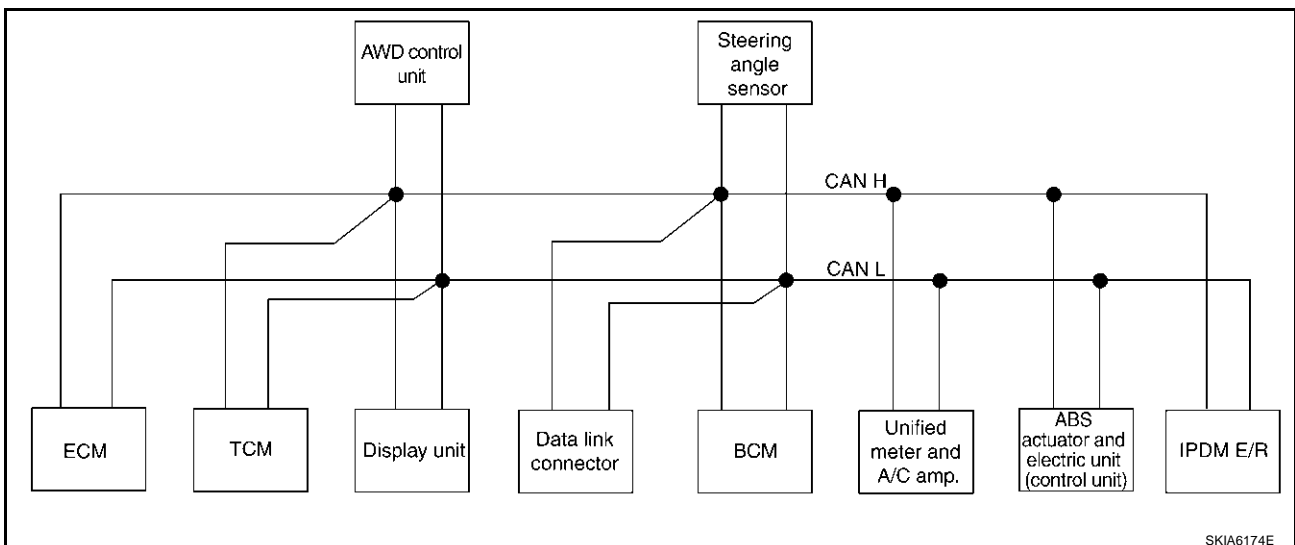

UNIFIED METER AND A/C AMP

● Type5

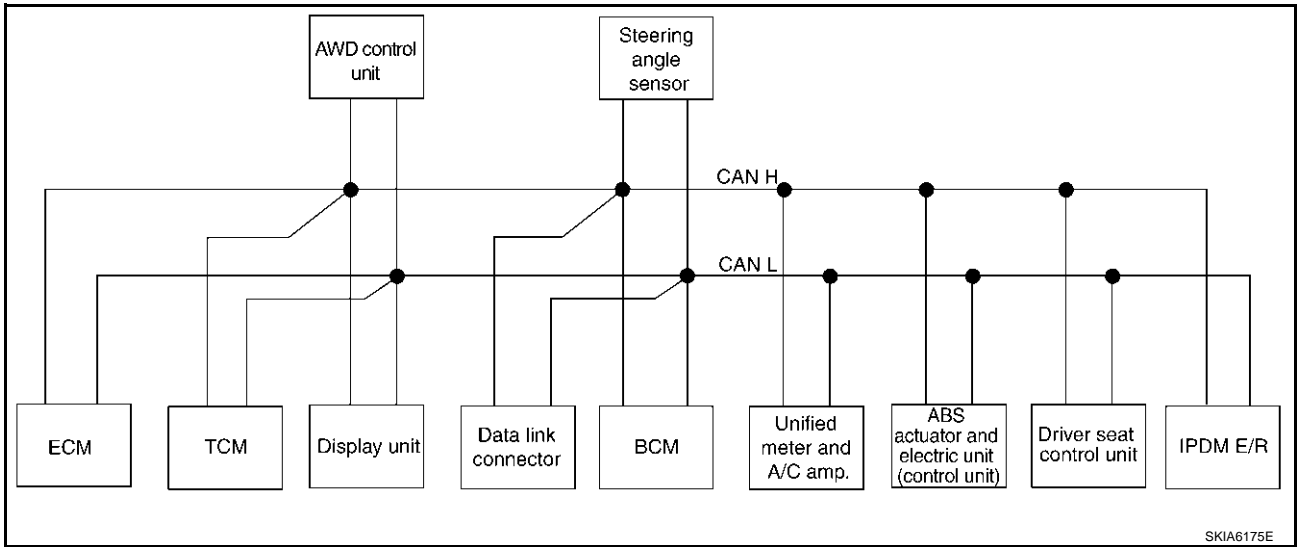

Input/output Signal Chart

T: Transmit R: Receive

Signals	ECM	TCM	Display unit	AWD control unit	BCM	Steering angle sensor	Unified meter and A/C amp.	ABS actuator and electric unit (control unit)	Driver seat control unit	IPDM E/R
A/T self-diagnosis signal	R	T								
ABS operation signal	R			R				T		
TCS operation signal	R							T		
VDC operation signal	R			R				T		
Stop lamp switch signal		R		R			T			
Battery voltage signal	T	R								
Key switch signal					T				R	
Ignition switch signal					T				R	R
P range signal		T						R	R	
Closed throttle position signal	T	R								
Wide open throttle position signal	T	R								
Engine speed signal	T	R	R	R			R	R		
Engine status signal	T				R					
Engine coolant temperature signal	T	R					R			
Accelerator pedal position signal	T	R		R				R		
Fuel consumption monitor signal	T		R				R			
Input shaft revolution signal	R	T								
Output shaft revolution signal	R	T								
A/C switch signal	R				T					
A/C compressor request signal	T									R
A/C relay status signal	R									T
A/C compressor feedback signal	T						R			

UNIFIED METER AND A/C AMP

Signals	ECM	TCM	Display unit	AWD control unit	BCM	Steering angle sensor	Unified meter and A/C amp.	ABS actuator and electric unit (control unit)	Driver seat control unit	IPDM E/R
Blower fan motor switch signal	R				T					
A/C control signal			T				R			
			R				T			
Cooling fan speed signal	R									T
Position light request signal			R		T		R			R
Low beam request signal					T					R
Low beam status signal	R									T
High beam request signal					T		R			R
High beam status signal	R									T
Front fog light request signal					T					R
Day time running light request signal					T		R			
Turn LED burnout status signal					R		T			
Vehicle speed signal							R	T		
	R	R	R		R		T		R	
Sleep wake up signal					T		R		R	R
Door switch signal			R		T		R		R	R
Turn indicator signal					T		R			
Key fob ID signal					T				R	
Key fob door unlock signal					T				R	
Oil pressure switch signal					R					T
					T		R			
Buzzer output signal					T		R			
Fuel level sensor signal	R						T			
Fuel level low warning signal			R				T			
Front wiper request signal					T					R
Front wiper stop position signal					R					T
Rear window defogger switch signal					T					R
Rear window defogger control signal	R		R		R					T
Hood switch signal					R					T
Theft warning horn request signal					T					R
Horn chirp signal					T					R
Steering angle sensor signal						T		R		
ABS warning lamp signal							R	T		
VDC OFF indicator lamp signal							R	T		
SLIP indicator lamp signal							R	T		
Brake warning lamp signal							R	T		
System setting signal			T		R				R	
AWD warning lamp signal				T			R			

UNIFIED METER AND A/C AMP

Signals	ECM	TCM	Display unit	AWD control unit	BCM	Steering angle sensor	Unified meter and A/C amp.	ABS actuator and electric unit (control unit)	Driver seat control unit	IPDM E/R
AWD lock indicator lamp signal				T			R			
Distance to empty signal			R				T			
Hand brake switch signal				R	R		T			
ASCD operation signal	T	R								
ASCD OD cancel request	T	R								
A/T CHECK indicator lamp signal		T					R			
A/T position indicator lamp signal		T					R			
A/T shift schedule change demand signal		R						T		
Manual mode signal		R					T			
Not manual mode signal		R					T			
Manual mode shift up signal		R					T			
Manual mode shift down signal		R					T			
Manual mode indicator signal		T					R			

TYPE 6

System Diagram

- Type6

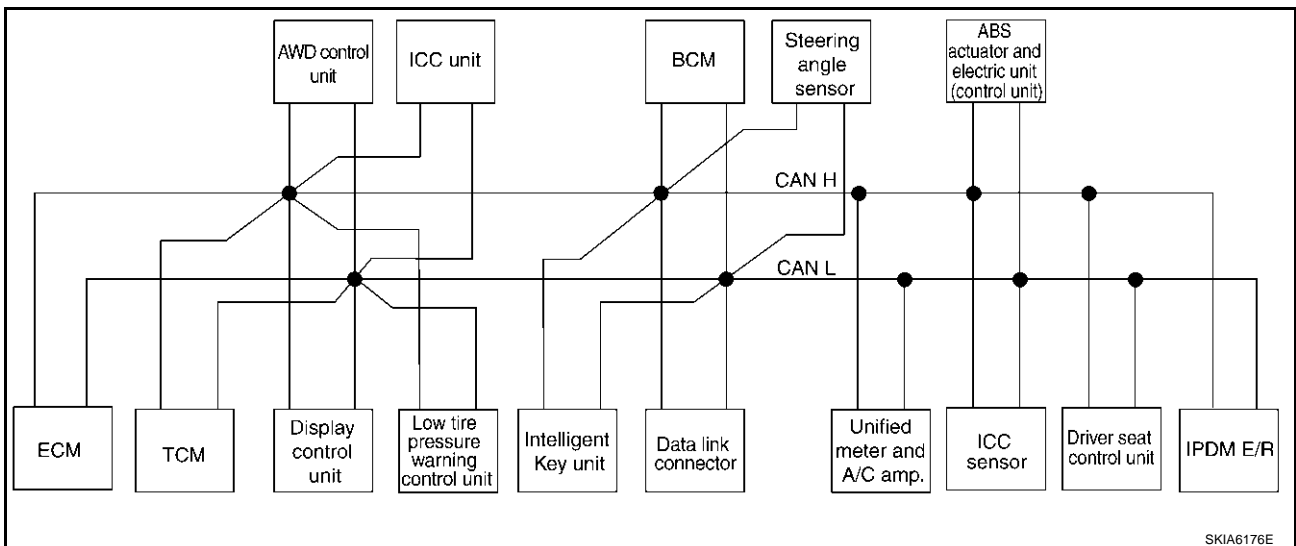

UNIFIED METER AND A/C AMP

Input/output Signal Chart

T: Transmit R: Receive

Signals	ECM	TCM	Display control unit	Low tire pressure warning control unit	AWD control unit	ICC unit	Intelligent Key unit	BCM	Steering angle sensor	Unified meter and A/C amp.	ICC sensor	ABS actuator and electric unit (control unit)	Driver seat control unit	IPD M E/R
A/T self-diagnosis signal	R	T												
ABS operation signal	R				R	R						T		
TCS operation signal	R					R						T		
VDC operation signal	R				R	R					R	T		
Stop lamp switch signal		R			R					T				
Battery voltage signal	T	R												
Key switch signal								T					R	
Ignition switch signal								T					R	R
P range signal		T				R						R	R	
Closed throttle position signal	T	R				R								
Wide open throttle position signal	T	R												
Engine speed signal	T	R	R		R	R				R		R		
Engine status signal	T							R						
Engine coolant temperature signal	T	R				R				R				
Accelerator pedal position signal	T	R			R	R						R		
Fuel consumption monitor signal	T		R							R				
A/T self-diagnosis signal	R	T												
Input shaft revolution signal	R	T				R								
Output shaft revolution signal	R	T				R								
A/C switch signal	R							T						
A/C compressor request signal	T													R
A/C relay status signal	R													T
A/C compressor feedback signal	T									R				
Blower fan motor switch signal	R							T						
A/C control signal			T							R				
			R							T				
Cooling fan speed signal	R													T
Position light request signal			R					T		R				R
Low beam request signal								T						R
Low beam status signal	R													T
High beam request signal								T		R				R

UNIFIED METER AND A/C AMP

Signals	ECM	TCM	Display control unit	Low tire pressure warning control unit	AWD control unit	ICC unit	Intelligent Key unit	BCM	Steering angle sensor	Unified meter and A/C amp.	ICC sensor	ABS actuator and electric unit (control unit)	Driver seat control unit	IPD M E/ R
High beam status signal	R													T
Front fog light request signal								T						R
Day time running light request signal								T		R				
Turn LED burnout status signal								R		T				
Vehicle speed signal						R				R		T		
	R	R	R	R			R	R		T	R		R	
Sleep wake up signal								T		R			R	R
							T	R						
Door switch signal			R				R	T		R			R	R
Key fob ID signal								T					R	
Key fob door unlock signal								T					R	
Oil pressure switch signal								R						T
								T		R				
Buzzer output signal							T			R				
						T				R				
Fuel level sensor signal	R									T				
Fuel level low warning signal			R							T				
ICC operation signal	R					T								
Front wiper request signal						R		T						R
Front wiper stop position signal								R						T
Rear window defogger switch signal								T						R
Rear window defogger control signal	R		R					R						T
Hood switch signal								R						T
Theft warning horn request signal								T						R
Horn chirp signal								T						R
Steering angle sensor signal									T			R		
Tire pressure signal				T						R				
Tire pressure data signal			R	T										
ABS warning lamp signal						R				R		T		
VDC OFF indicator lamp signal						R				R		T		
SLIP indicator lamp signal										R		T		

A
B
C
D
E
F
G
H
I
J
L
M

DI

UNIFIED METER AND A/C AMP

Signals	ECM	TCM	Display control unit	Low tire pressure warning control unit	AWD control unit	ICC unit	Intelligent Key unit	BCM	Steering angle sensor	Unified meter and A/C amp.	ICC sensor	ABS actuator and electric unit (control unit)	Driver seat control unit	IPD M E/ R
Brake warning lamp signal										R		T		
System setting signal			T				R						R	
AWD warning lamp signal					T					R				
AWD lock indicator lamp signal					T					R				
Distance to empty signal			R							T				
Hand brake switch signal					R			R		T				
Door lock/unlock request signal							T	R						
Door lock/unlock status signal							R	T						
Starter permission signal							T	R						
Back door open request signal							T	R						
Power window open request signal							T	R						
Alarm request signal							T	R						
Key warning signal							T			R				
ICC sensor signal						R					T			
ICC warning lamp signal						T				R				
ICC system display signal						T				R				
Current gear position signal		T				R						R		
Steering switch signal	T					R								
ASCD operation signal	T	R												
ASCD OD cancel request	T	R												
ICC OD cancel request	R	R				T								
A/T CHECK indicator lamp signal		T								R				
A/T position indicator lamp signal		T								R				
A/T shift schedule change demand signal		R										T		
Manual mode signal		R								T				
Not manual mode signal		R								T				
Manual mode shift up signal		R								T				
Manual mode shift down signal		R								T				
Manual mode indicator signal		T								R				
Ignition knob switch signal							T	R						

UNIFIED METER AND A/C AMP

Schematic

AKS005NA

A
B
C
D
E
F
G
H
I
J
K
L
M

DI

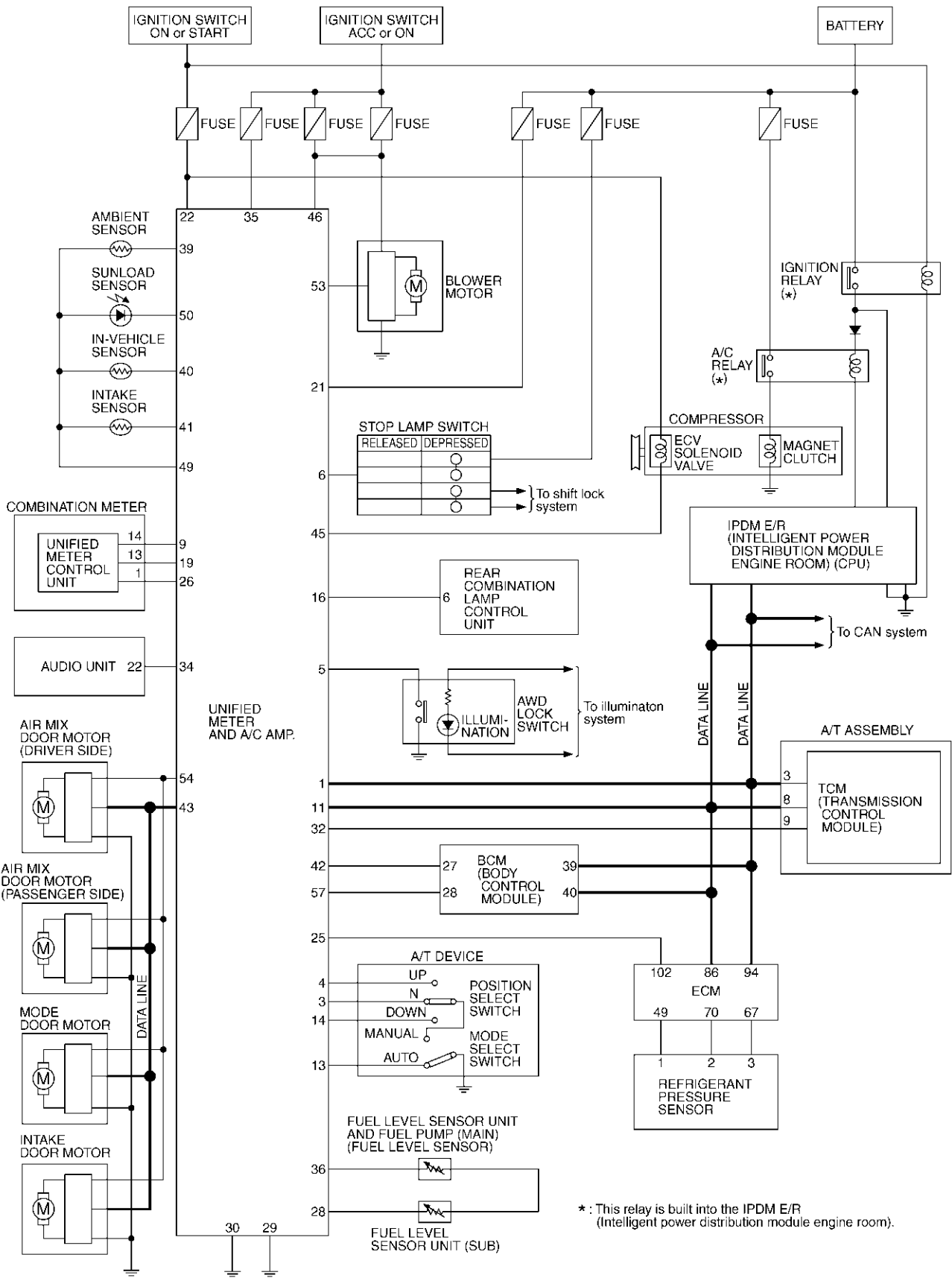

* : This relay is built into the IPDM E/R (Intelligent power distribution module engine room).

TKWM0704E

UNIFIED METER AND A/C AMP

AKS005NB

CONSULT-II Function

CONSULT-II executes the following functions by combining data reception and command transmission via the communication line from unified meter and A/C amp. Self-diagnostic results and data monitor display.

System part	Check item, diagnosis mode	Description
METER A/C AMP	Self-diagnostic results	Unified meter and A/C amp. check the conditions and indicates any error that unified meter and A/C amp. memorized.
	CAN diagnostic support monitor	The results of transmit/receive diagnosis of CAN communication can be read.
	Data monitor	Displays unified meter and A/C amp. input data in real time.

CONSULT-II BASIC OPERATION

CAUTION:

If CONSULT-II is used with no connection of CONSULT-II CONVERTER, malfunctions might be detected in self-diagnosis depending on control unit which carry out CAN communication.

1. With the ignition switch OFF, connect "CONSULT-II" and "CONSULT-II CONVERTER" to the data link connector, then turn ignition switch ON.

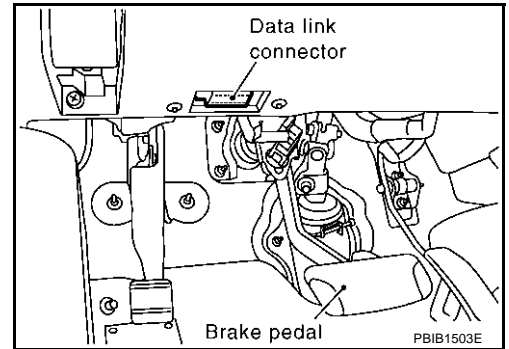

2. Touch "START (NISSAN BASED VHCL)".

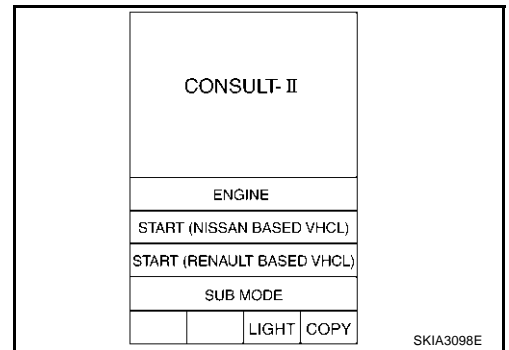

3. Touch "METER A/C AMP" on "SELECT SYSTEM" screen. If "METER A/C AMP" is not indicated, go to [LAN-4, "Precautions When Using CONSULT-II"](#).
4. Select "SELF-DIAG RESULTS", "CAN DIAGNOSTIC SUPPORT MONITOR" or "DATA MONITOR".

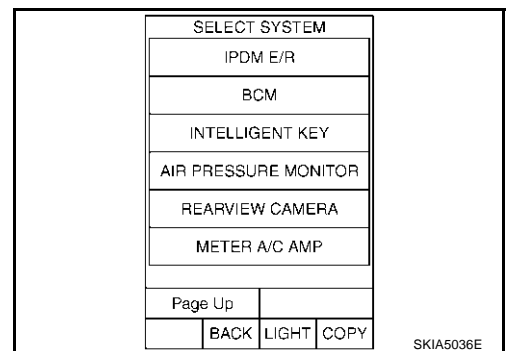

UNIFIED METER AND A/C AMP

SELF-DIAGNOSTIC RESULTS

Operation Procedure

1. Touch "SELF-DIAG RESULTS" on "SELECT DIAG MODE" screen.
2. Self-diagnosis results are displayed.

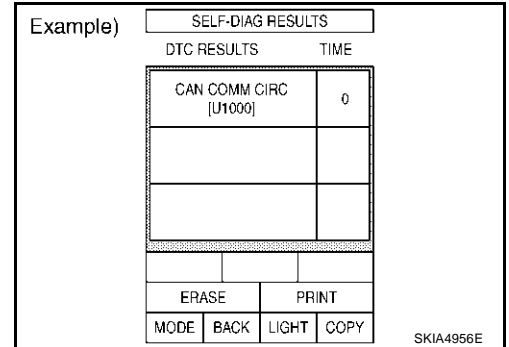

Display Item List

CONSULT-II display	Malfunction is detected when...
CAN COMM CIRC [U1000]	<p>Malfunction is detected in CAN communication.</p> <p>CAUTION: Even when there is no malfunction on CAN communication system, malfunction may be misinterpreted when battery has low voltage (when maintaining 7V-8V for about 2 seconds) or 10A fuse [No. 19, located in the fuse block (J/B)] is disconnected.</p>
METER COMM CIRC [B2202]	<p>Malfunction is detected in communication of between combination meter and unified meter and A/C amp.</p>
VEHICLE SPEED CIRC [B2205]	<p>When an erroneous speed signal is input for 1 seconds.</p> <p>CAUTION: Even when there is no malfunction on speed signal system, malfunction may be misinterpreted when battery has low voltage (when maintaining 7V-8V for about 2 seconds).</p>

"TIME" indicates the condition of the self-diagnosis results judged by each signal input.

- Normal: In case of operating properly at the present in spite of having malfunction in the past, then "TIME" indicates "1-63".
- Malfunction: Soon after detecting malfunctions by self-diagnoses or current malfunction, "0" is indicated.

After returning to normal condition, every time when ignition switch is turned to "OFF" from "ON", time will be added like "1"→"2"→"3"..."63", and when the key operation is performed 64 times, the result of the self-diagnoses will be erased. And if any malfunction is detected again, "0" will be indicated.

CAUTION:

"TIME" keeps showing "0" after returning to normal condition only in the case that malfunction history of "CAN COMM CIRC [U1000]" remains because of low tire pressure warning control unit, display control unit (with NAVI) or display unit (without NAVI) malfunction.

DATA MONITOR

Operation Procedure

1. Touch "DATA MONITOR" on "SELECT DIAG MODE" screen.
2. Touch either "MAIN SIGNALS" or "SELECTION FROM MENU" on the "DATA MONITOR" screen.

MAIN SIGNALS	Monitors main signals.
SELECTION FROM MENU	Selects and monitors individual signal.

3. When "SELECTION FROM MENU" is selected, touch individual items to be monitored. When "MAIN SIGNALS" is selected, main items will be monitored.

UNIFIED METER AND A/C AMP

4. Touch "START".
5. Touch "RECORD" while monitoring, then the status of the monitored item can be recorded. To stop recording, touch "STOP".

Example)

DATA MONITOR			
MONITOR			
SPEED METER	0.0km/h		
SPEED OUTPUT	0.0km/h		
TACHO METER	0 rpm		
W TEMP METER	26°C		
FUEL METER	6 lit.		
DISTANCE	0 km		
FUEL W/L	ON		
BUZZER	OFF		
M RANGE SW	OFF		
		Page Down	
		STOP	
MODE	BACK	LIGHT	COPY

SKIA4957E

Display Item List

Display item [Unit]	MAIN SIGNALS	SELECTION FROM MENU	Contents
SPEED METER [km/h] or [mph]	X	X	This is the angle correction value after the speed signal from the ABS actuator and electric unit (control unit) is converted into the vehicle speed.
SPEED OUTPUT [km/h] or [mph]	X	X	This is the angle correction value before the speed signal from the ABS actuator and electric unit (control unit) is converted into the vehicle speed.
TACHO METER [rpm]	X	X	This is the converted value for the engine speed signal from the ECM.
W TEMP METER [°C] or [°F]	X	X	This is the converted value for the engine coolant temperature signal from the ECM.
FUEL METER [lit.]	X	X	This is the processed value for the signal (resistance value) from the fuel gauge.
DISTANCE [km] or [mile]	X	X	This is the calculated value for the speed signal from the ABS actuator and electric unit (control unit), the signal (resistance signal) from the fuel gauge and fuel consumption signal from ECM.
FUEL W/L [ON/OFF]	X	X	Indicates [ON/OFF] condition of low-fuel warning lamp.
MIL [ON/OFF]		X	Indicates [ON/OFF] condition of malfunction indicator lamp.
AIR PRES W/L [ON/OFF]		X	Indicates [ON/OFF] condition of low tire pressure warning lamp.
SEAT BELT W/L [ON/OFF]		X	Indicates [ON/OFF] condition of seat belt warning lamp.
BUZZER [ON/OFF]	X	X	Indicates [ON/OFF] condition of buzzer.
DOOR W/L [ON/OFF]		X	Indicates [ON/OFF] condition of door warning lamp.
HI-BEAM IND [ON/OFF]		X	Indicates [ON/OFF] condition of high beam indicator.
TURN IND [ON/OFF]		X	Indicates [ON/OFF] condition of turn indicator.
OIL W/L [ON/OFF]		X	Indicates [ON/OFF] condition of oil pressure warning lamp.
VDC/TCS IND [ON/OFF]		X	Indicates [ON/OFF] condition of VDC OFF indicator lamp.
ABS W/L [ON/OFF]		X	Indicates [ON/OFF] condition of ABS warning lamp.
SLIP IND [ON/OFF]		X	Indicates [ON/OFF] condition of SLIP indicator lamp.
BRAKE W/L [ON/OFF]		X	Indicates [ON/OFF] condition of brake warning lamp.*
KEY G W/L [ON/OFF]		X	Indicates [ON/OFF] condition of key warning lamp (green).
KEY R W/L [ON/OFF]		X	Indicates [ON/OFF] condition of key warning lamp (red).
KEY KNOB W/L [ON/OFF]		X	Indicates [ON/OFF] condition of key knob warning lamp.
M RANGE SW [ON/OFF]	X	X	Indicates [ON/OFF] condition of manual mode range switch.
NM RANGE SW [ON/OFF]	X	X	Indicates [ON/OFF] condition of except for manual mode range switch.
AT SFT UP SW [ON/OFF]	X	X	Indicates [ON/OFF] condition of A/T shift- up switch.
AT SFT DWN SW [ON/OFF]	X	X	Indicates [ON/OFF] condition of A/T shift- down switch.

UNIFIED METER AND A/C AMP

Display item [Unit]	MAIN SIGNALS	SELECTION FROM MENU	Contents
BRAKE SW [ON/OFF]		X	Indicates [ON/OFF] condition of brake switch (Stop lamp switch).
AT-M IND [ON/OFF]	X	X	Indicates [ON/OFF] condition of A/T manual mode indicator.
AT-M GEAR [5-1]	X	X	Indicates [5-1] condition of A/T manual mode gear position.
P RANGE IND [ON/OFF]	X	X	Indicates [ON/OFF] condition of A/T shift P range indicator.
R RANGE IND [ON/OFF]	X	X	Indicates [ON/OFF] condition of A/T shift R range indicator.
N RANGE IND [ON/OFF]	X	X	Indicates [ON/OFF] condition of A/T shift N range indicator.
D RANGE IND [ON/OFF]	X	X	Indicates [ON/OFF] condition of A/T shift D range indicator.
AT CHECK W/L		X	Indicates [ON/OFF] condition of AT CHECK warning lamp.
CRUISE IND [ON/OFF]		X	Indicates [ON/OFF] condition of CRUISE indicator.
SET IND [ON/OFF]		X	Indicates [ON/OFF] condition of SET indicator.
CRUISE W/L [ON/OFF]		X	Indicates [ON/OFF] condition of CRUISE warning lamp.
4WD LOCK SW [ON/OFF]		X	Indicates [ON/OFF] condition of AWD LOCK switch.
4WD LOCK IND [ON/OFF]		X	Indicates [ON/OFF] condition of AWD LOCK indicator lamp.
4WD W/L [ON/OFF]		X	Indicates [ON/OFF] condition of AWD warning lamp.

NOTE:

Any monitored item that does not match the vehicle being diagnosed is deleted from the display automatically.
 *: Monitor keeps indicating "OFF" when brake warning lamp is on by the parking brake operation or low brake fluid level.

Removal and Installation of Unified Meter and A/C Amp.

AKS005NC

REMOVAL

1. Remove the audio unit. Refer to [AV-42, "Removal and Installation of Audio Unit"](#).
2. Remove the fixing screws, then remove the unified meter and A/C amp.

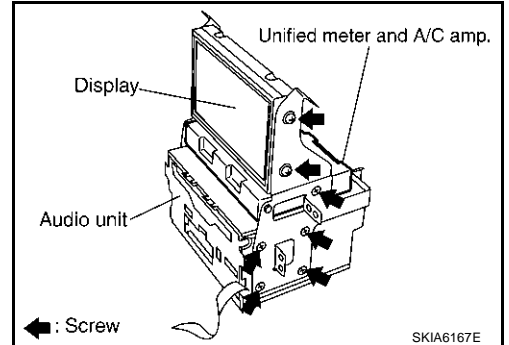

INSTALLATION

Installation is basically in the reverse order of removal.

COMPASS

COMPASS

PFP:24835

System Description

AKS007A0

This unit displays earth magnetism and heading direction of vehicle.

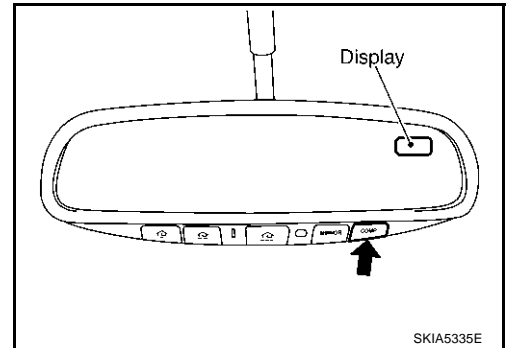

DIRECTION DISPLAY

Push the switch when the ignition key is in the "ON" or "START" position. The direction will be displayed. Pushing the "COMP" switch a second time will turn off the display.

1. If the display reads "C" calibrate the compass by driving the vehicle in 3 complete circles at less than 8 km/h (5 MPH).
2. To adjust for compass variance:
 - a. Press the "COMP" switch for more than 3 seconds. The current zone number will appear in the display.
 - b. Find your current location and variance zone number on the zone map.
 - c. Press the "COMP" switch until the new zone number appears in the display. After you stop pressing the button in, the display will show a compass direction within a few seconds.

NOTE:

1. Do not install the ski rack, antenna, etc. which are attached to the vehicle by means of a magnet. They affect the operation of the compass.
 2. If the compass deviates from the correct indication soon after repeated adjustment, have the compass checked at an authorized dealer.
 3. The compass may not indicate the correct compass point in tunnels or while driving up or down a steep hill. (The compass returns to the correct compass point when the vehicle moves to an area where the geomagnetism is stabilized.)
3. Cleaning the Mirror
When cleaning the mirror, use a paper towel or similar material dampened with glass cleaner. Do not spray glass cleaner directly on the mirror as that may cause the liquid cleaner to enter the mirror housing.

COMPASS

“C” is Displayed in the Compass Window

The compass needs to be calibrated. Drive the vehicle in 3 circles at 8km/h (5 MPH) or less until the display reads a direction. You can also calibrate the compass by driving your vehicle on your everyday routine. The compass will be calibrated once it has tracked 3 complete circles.

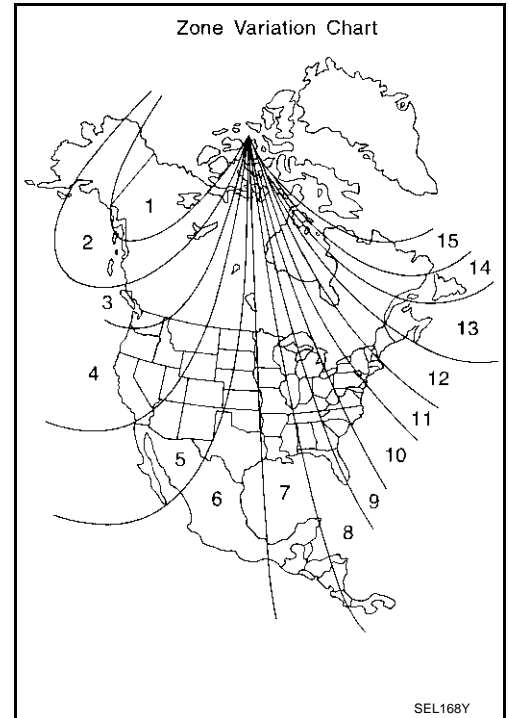

Inaccurate Compass Direction

1. With the display turned on, push the “COMP” switch for 3 seconds, until the zone selection comes up (a number will be displayed in the mirror compass window).
2. Toggle until correct zone is found and release switch.
3. The display will show all segments, and return to the normal compass mode within 10 seconds of no switch activity.
4. If the vehicle changes zone, repeat steps 1 through 3. See map.

A
B
C
D
E
F
G
H
I
J
DI
L
M

COMPASS

AKS007AP

Wiring Diagram – COMPAS –

DI-COMPAS-01

REFER TO PG-POWER.

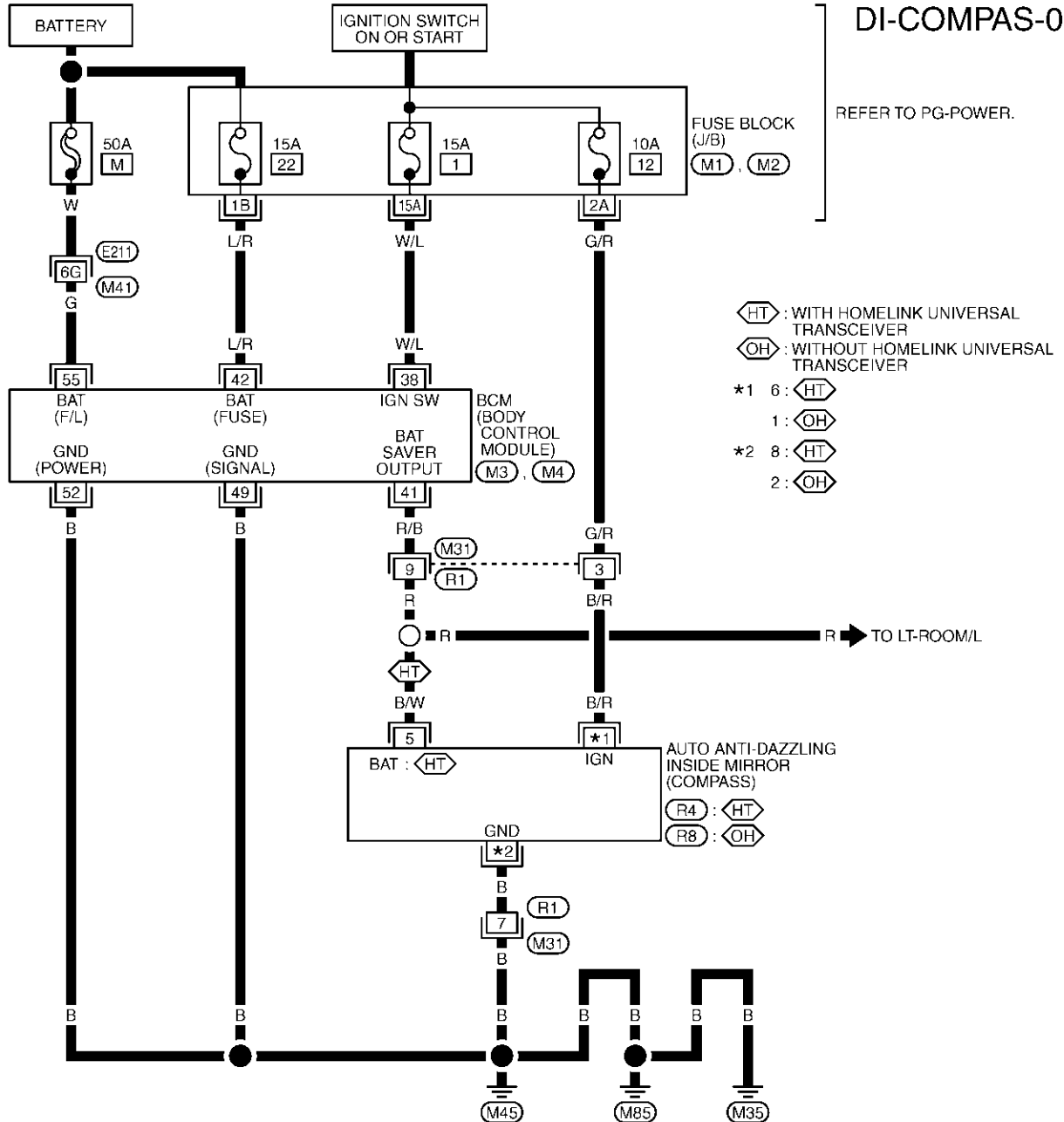

- ◊HT : WITH HOMELINK UNIVERSAL TRANSCEIVER
- ◊OH : WITHOUT HOMELINK UNIVERSAL TRANSCEIVER
- *1 6: ◊HT
- 1: ◊OH
- *2 8: ◊HT
- 2: ◊OH

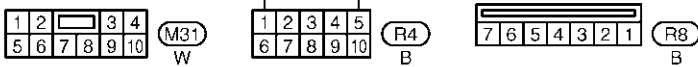

REFER TO THE FOLLOWING.

- ◊E211 - SUPER MULTIPLE JUNCTION (SMJ)
- ◊M1, ◊M2 - FUSE BLOCK-JUNCTION BOX (J/B)
- ◊M3, ◊M4 - ELECTRICAL UNITS

TKWM0683E

Removal and Installation of Compass

AKS007AQ

Refer to [GW-97, "Removal and Installation"](#) .

A

B

C

D

E

F

G

H

I

J

DI

L

M

WARNING LAMPS

PFP:24814

AKS005ND

WARNING LAMPS

Schematic

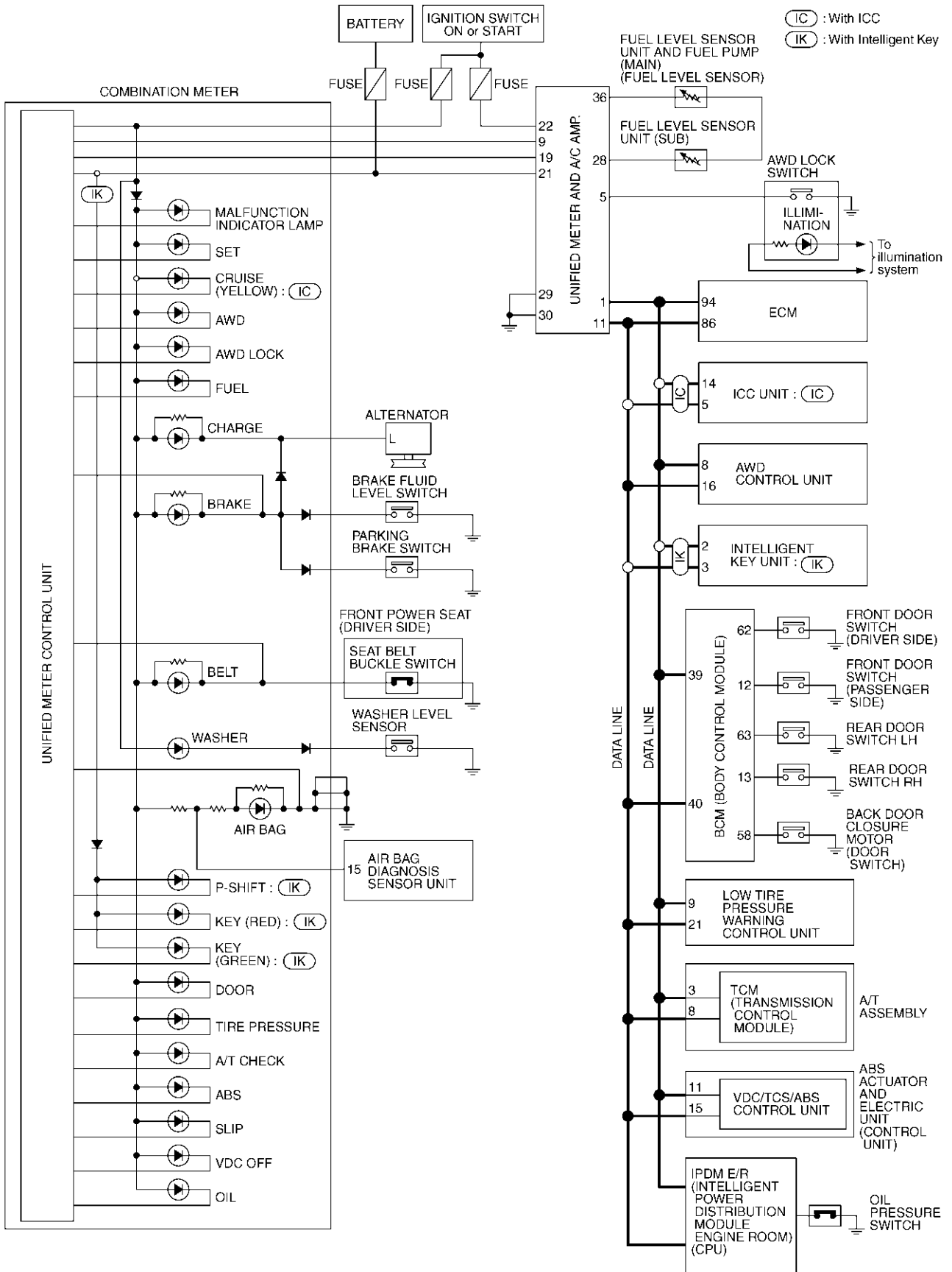

TKWM0684E

WARNING LAMPS

Wiring Diagram — WARN —

AKS005NE

DI-WARN-01

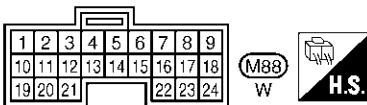
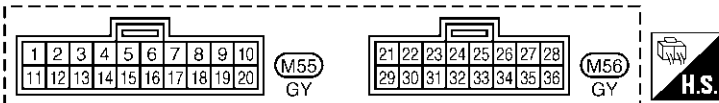
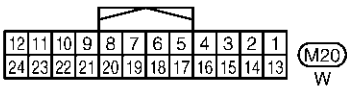
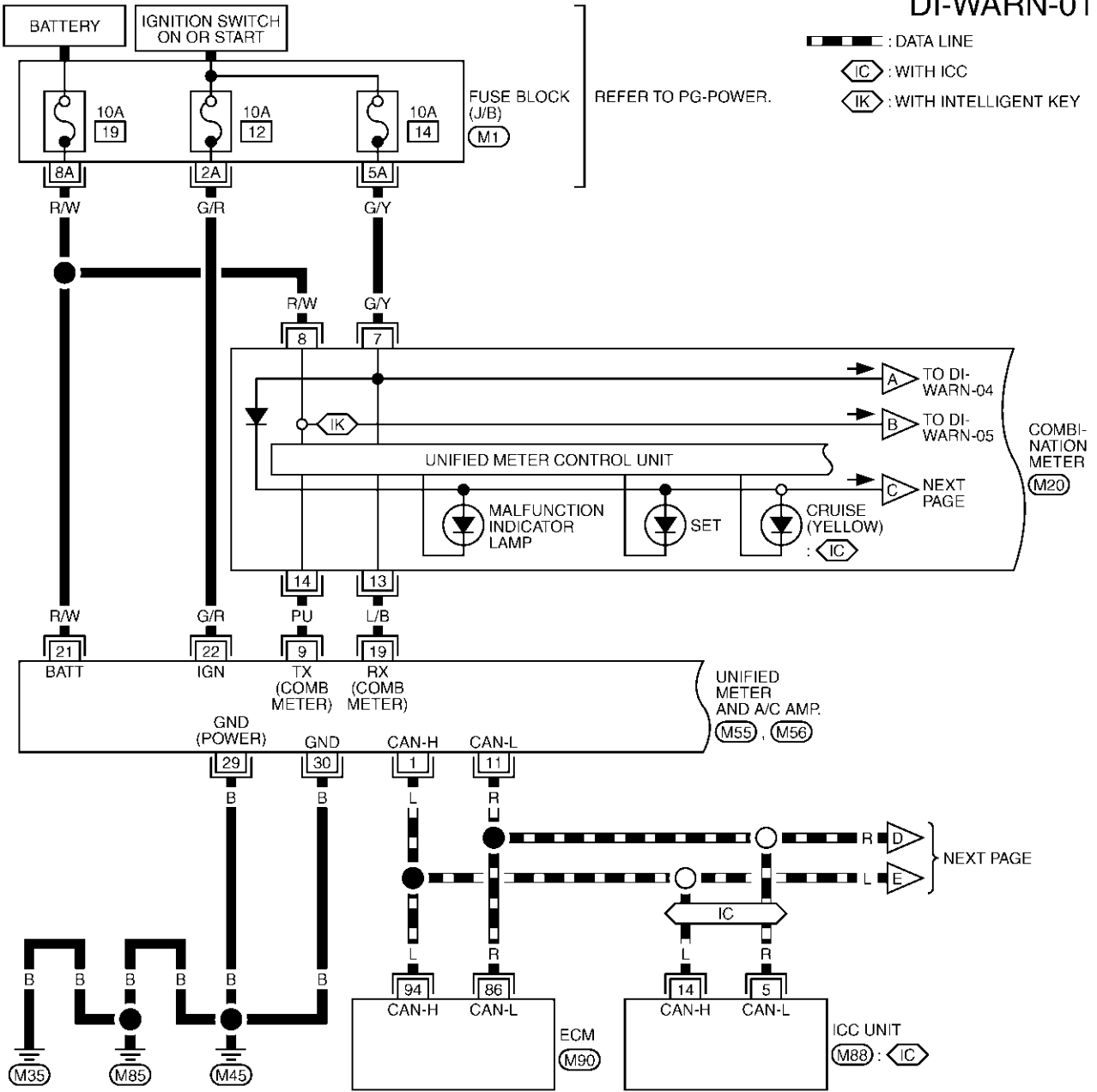

REFER TO THE FOLLOWING.

(M1) - FUSE BLOCK-JUNCTION BOX (J/B)

(M90) - ELECTRICAL UNITS

A
B
C
D
E
F
G
H
I
J
DI
L
M

WARNING LAMPS

DI-WARN-02

▬ : DATA LINE

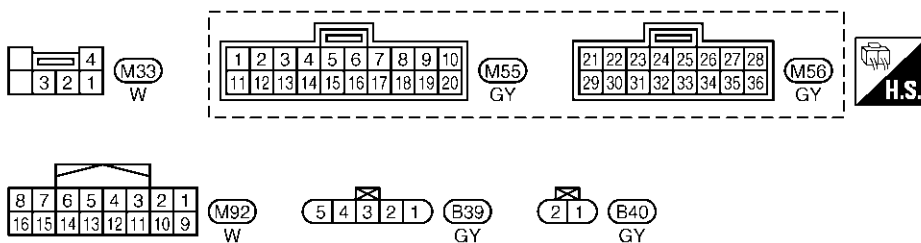
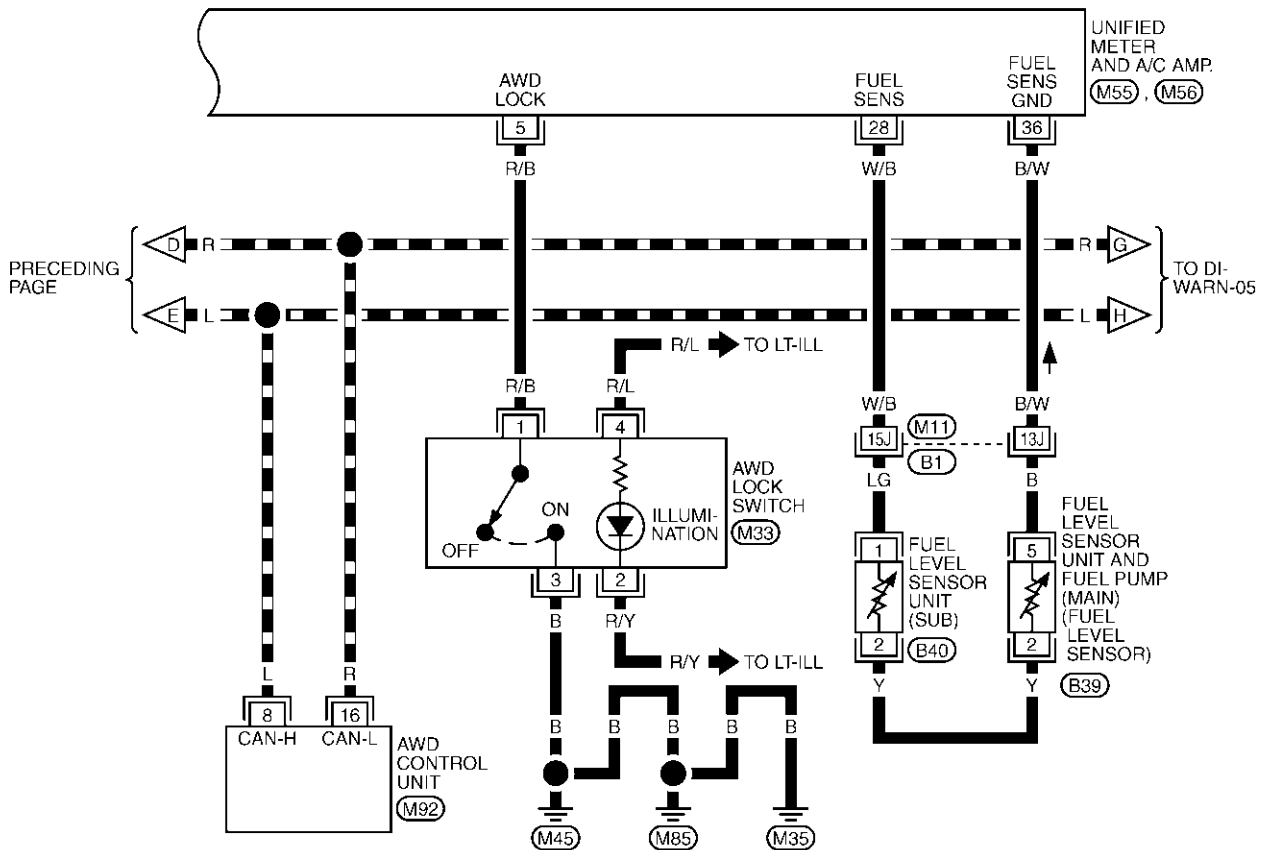
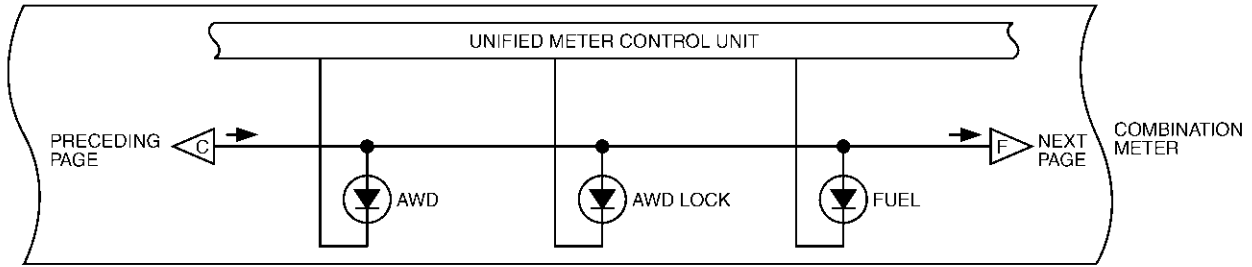

TKWM0686E

WARNING LAMPS

DI-WARN-03

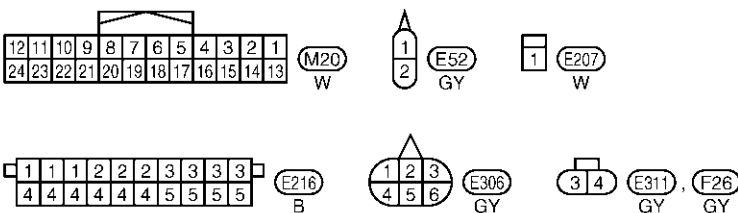
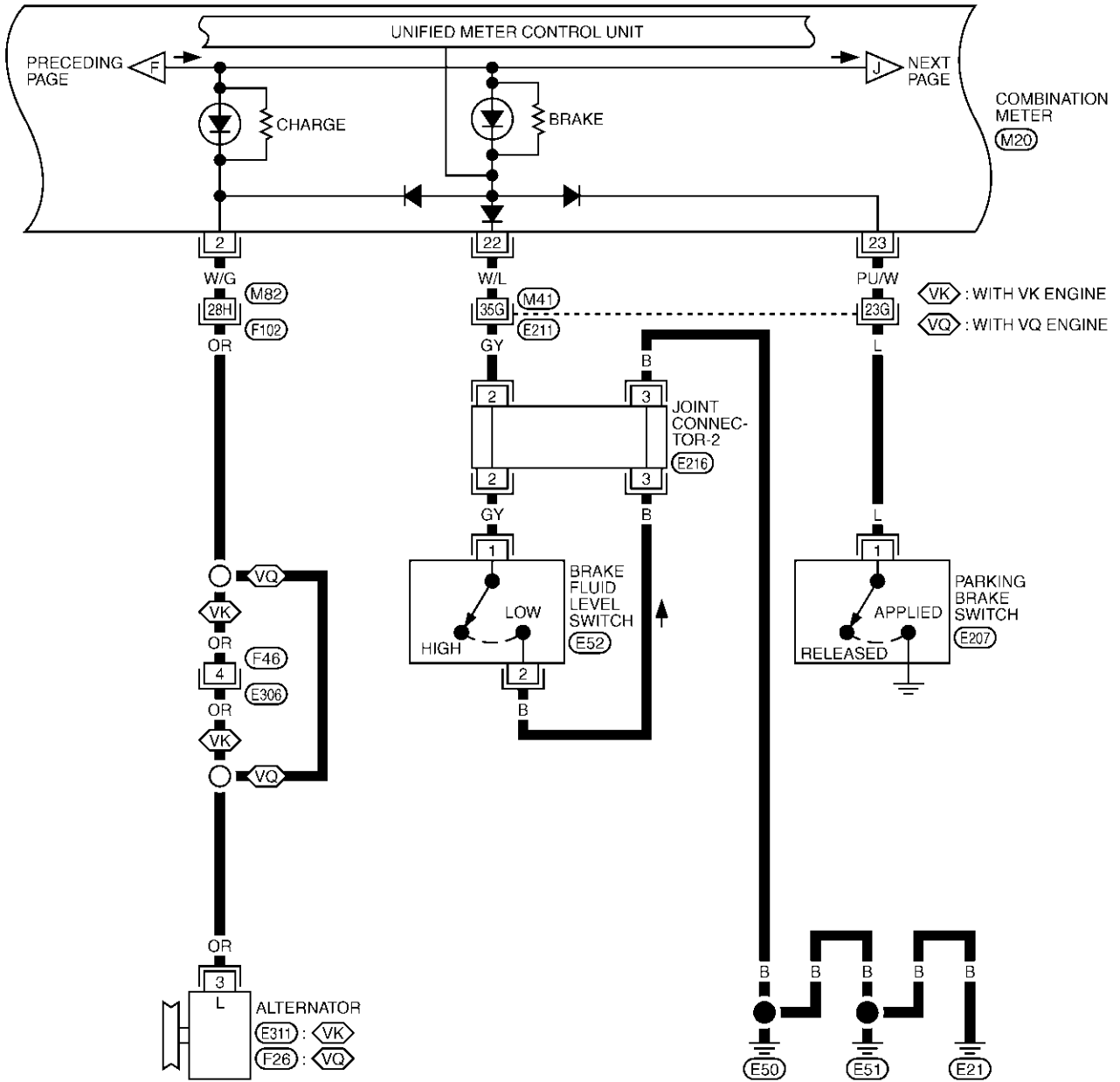

REFER TO THE FOLLOWING.
 (E211), (F102) -SUPER MULTIPLE JUNCTION (SMJ)

TKWM0687E

WARNING LAMPS

DI-WARN-04

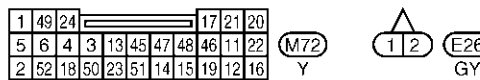
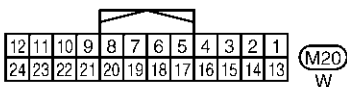
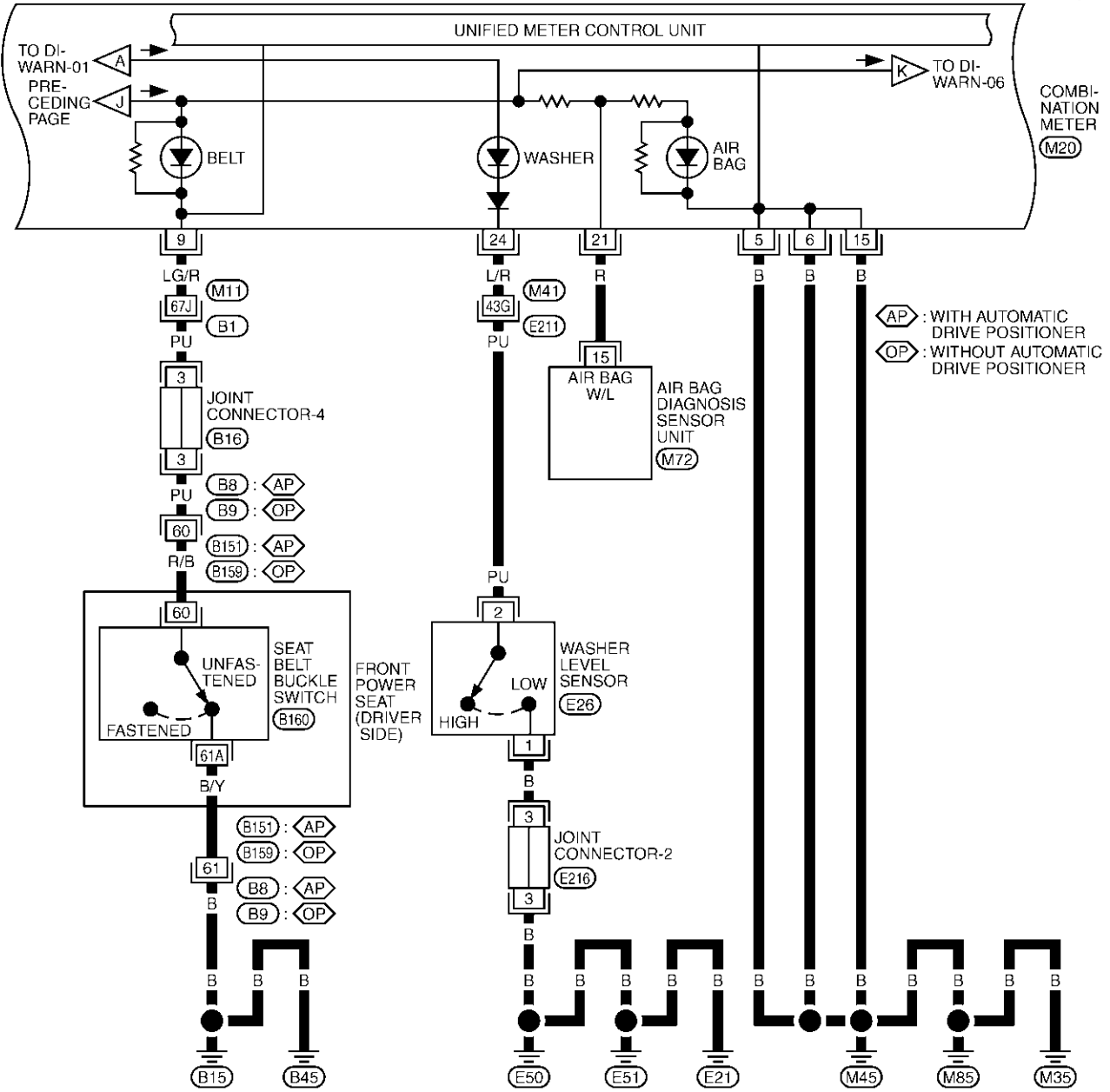

REFER TO THE FOLLOWING.
 (E21), (B1) -SUPER MULTIPLE JUNCTION (SMJ)

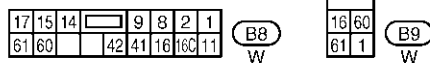
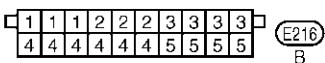

*: THIS CONNECTOR IS NOT SHOWN IN "HARNESS LAYOUT", PG SECTION.

TKWM0688E

WARNING LAMPS

DI-WARN-05

▬ : DATA LINE

◁IK▷ : WITH INTELLIGENT KEY

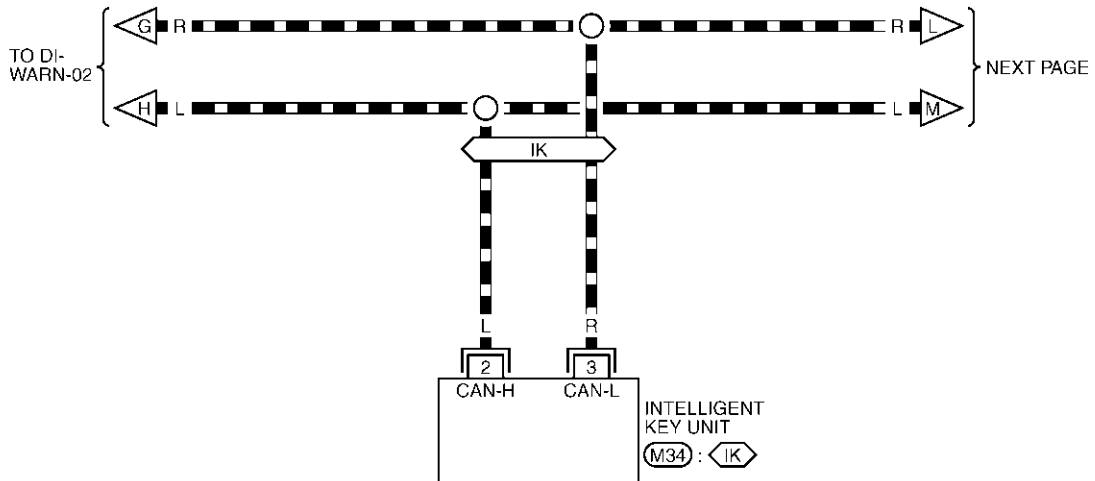
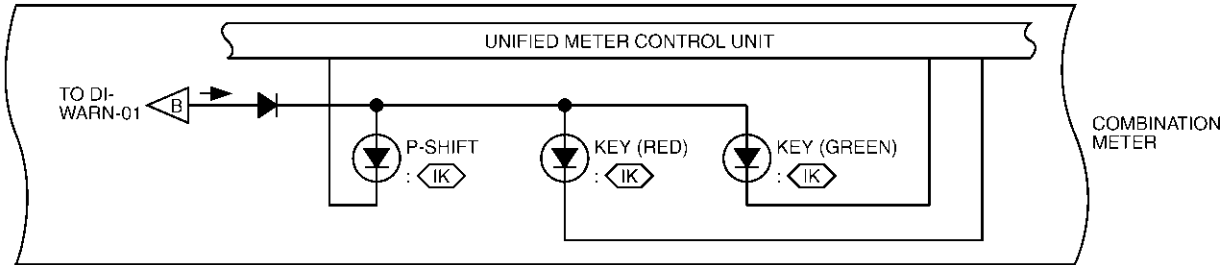

REFER TO THE FOLLOWING.
 (M34) -ELECTRICAL UNITS

TKWM0689E

WARNING LAMPS

DI-WARN-06

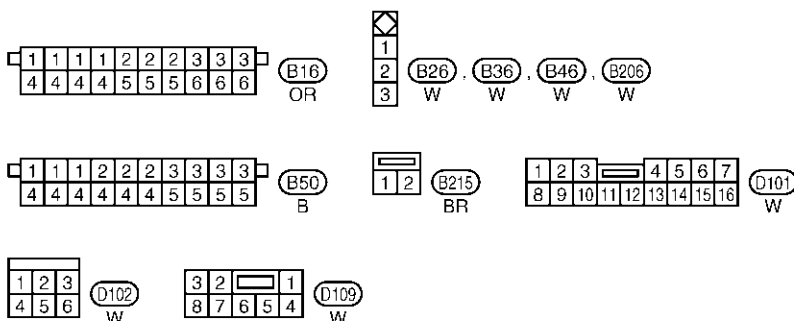
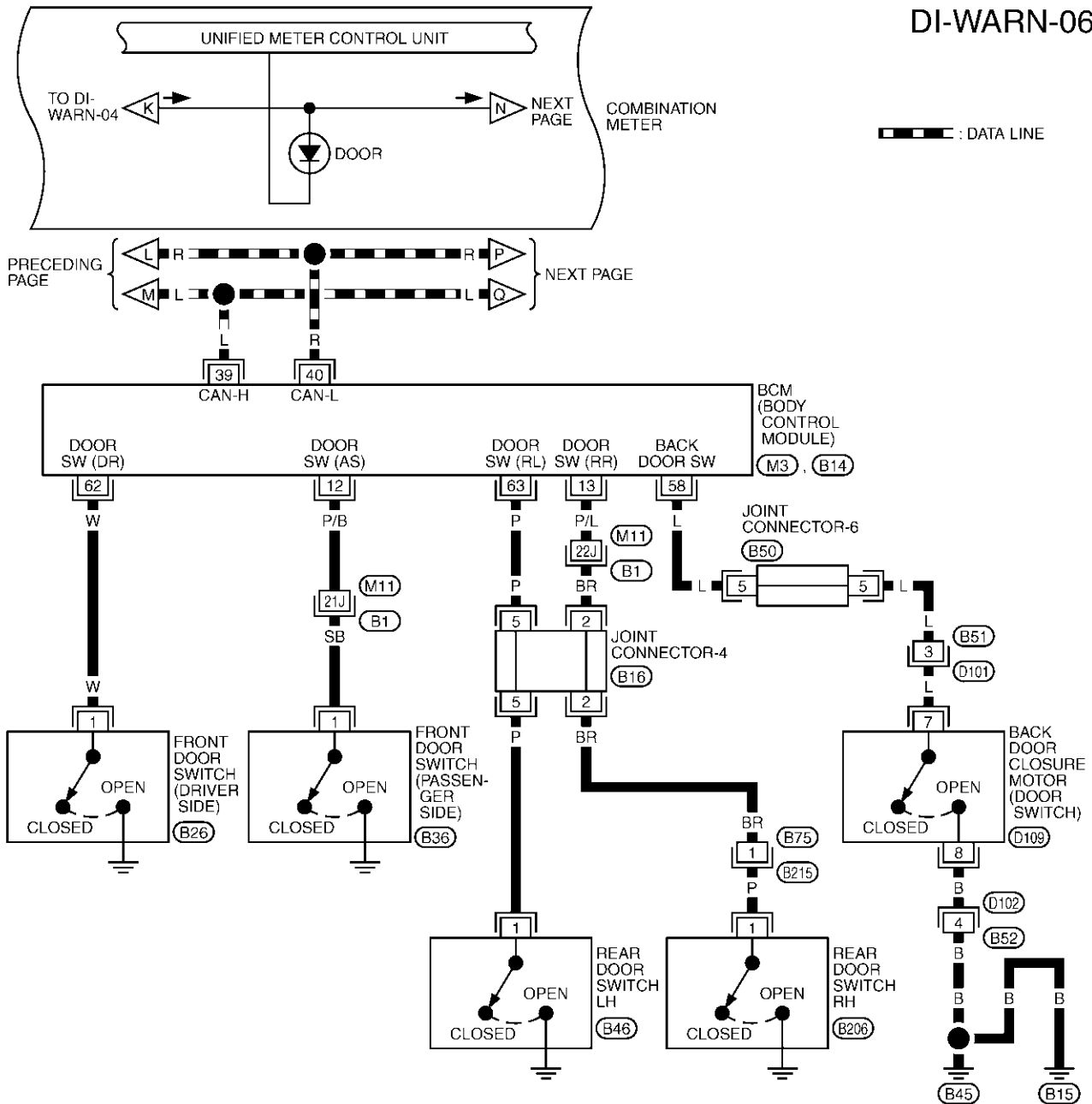

REFER TO THE FOLLOWING.

- (B1) -SUPER MULTIPLE JUNCTION (SMJ)
- (M3), (B14) -ELECTRICAL UNITS

TKWM0690E

WARNING LAMPS

DI-WARN-07

▬ : DATA LINE

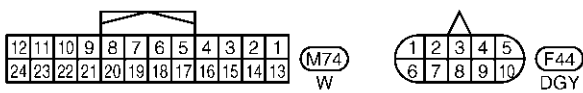
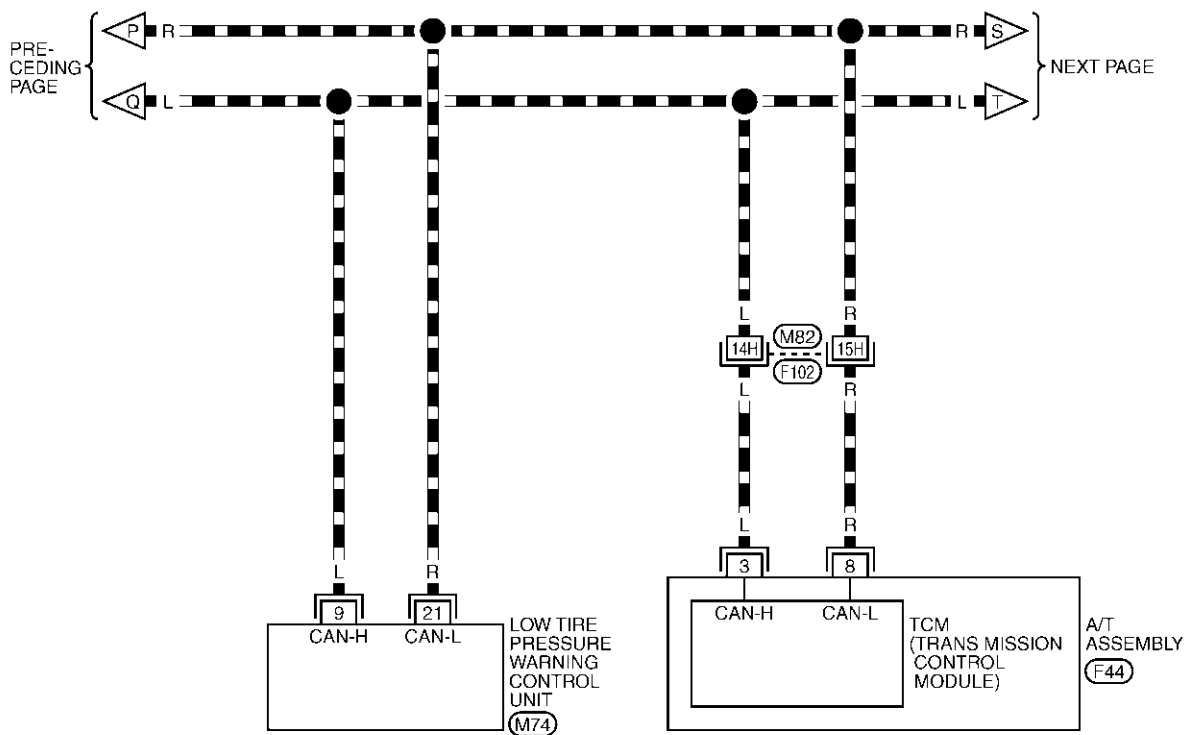
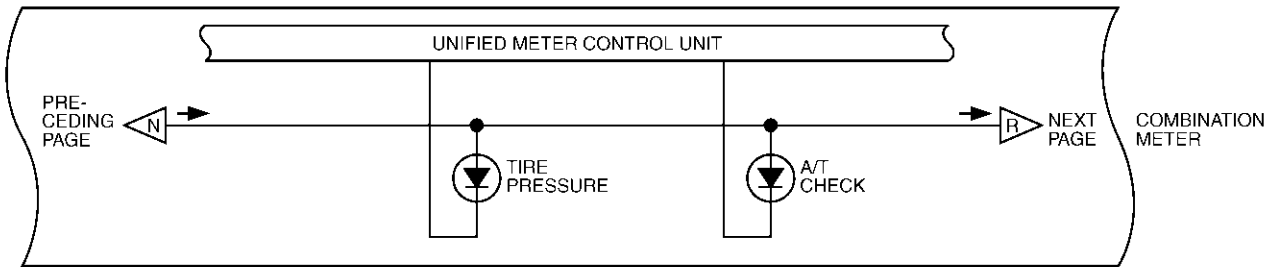

REFER TO THE FOLLOWING.
 (F102) -SUPER MULTIPLE JUNCTION (SMJ)

A
B
C
D
E
F
G
H
I
J
DI
L
M

WARNING LAMPS

DI-WARN-08

▬ : DATA LINE

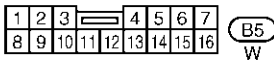
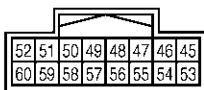
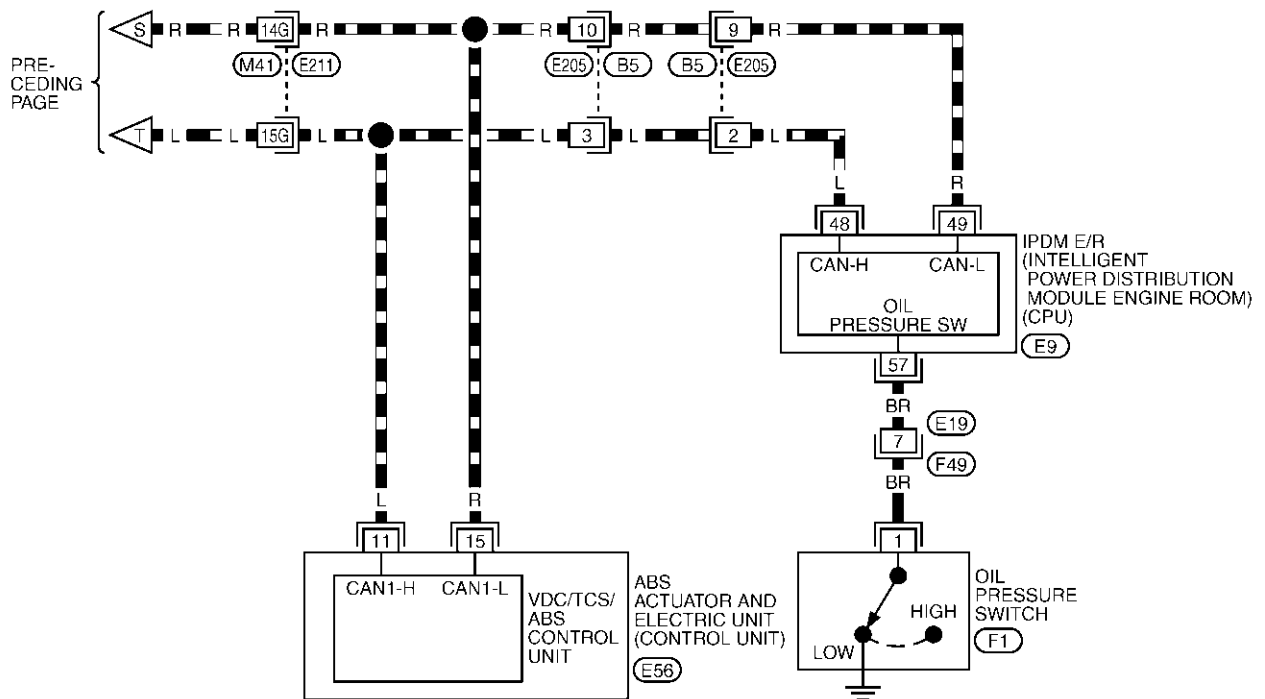
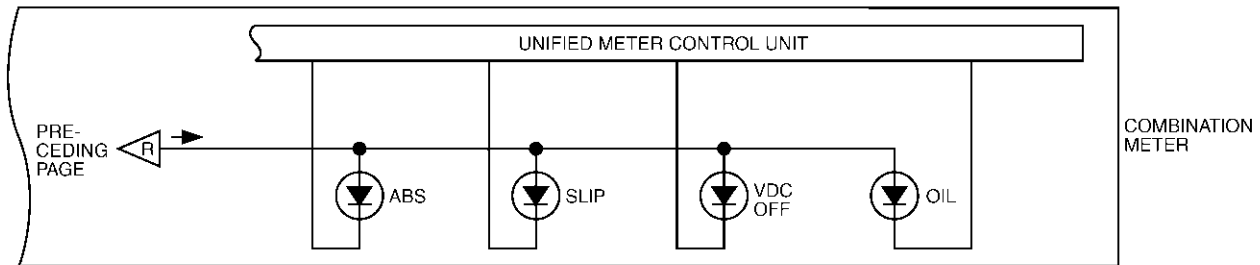

REFER TO THE FOLLOWING.

(E211) -SUPER MULTIPLE JUNCTION (SMJ)

(E56) -ELECTRICAL UNITS

TKWM0692E

WARNING LAMPS

Oil Pressure Warning Lamp Stays Off (Ignition Switch ON)

AKS005NF

1. CHECK SELF-DIAGNOSTIC RESULTS OF UNIFIED METER AND A/C AMP.

1. Start engine.
2. Select "METER A/C AMP" on CONSULT-II, and perform self-diagnosis of unified meter and A/C amp. Refer to [DI-48, "CONSULT-II Function"](#).
3. After erasing the self-diagnostic results, perform self-diagnosis again.

Self-diagnostic results content

No malfunction detected>> GO TO 2.

Malfunction detected>> Go to [DI-18, "Symptom Chart 2"](#) in "COMBINATION METER".

2. CHECK IPDM E/R OUTPUT SIGNAL

Activate IPDM E/R auto active test. Refer to [PG-39, "Auto Active Test"](#).

Does oil pressure warning lamp is blinking?

YES >> GO TO 5.

NO >> GO TO 3.

3. CHECK BCM INPUT SIGNAL

Select "DATA MONITOR" of "SIGNAL BUFFER". Refer to [BCS-25, "CONSULT-II"](#). Operate ignition switch with "OIL PRESS SW" of "DATA MONITOR" and check operate status.

When ignition switch is in ON : OIL PRESS SW ON position (Engine stopped)

When engine running : OIL PRESS SW OFF

OK or NG

OK >> GO TO 4.

NG >> Replace IPDM E/R. Refer to [PG-45, "Removal and Installation of IPDM E/R"](#).

DATA MONITOR	
MONITOR	
OIL PRESS SW	ON

SKIA8676E

4. CHECK UNIFIED METER AND A/C AMP. INPUT SIGNAL

Select "METER A/C AMP" on CONSULT-II. Operate ignition switch with "OIL W/L" of "DATA MONITOR" and check operation status.

When ignition switch is in ON : OIL W/L ON position (Engine stopped)

When engine running : OIL W/L OFF

OK or NG

OK >> Replace combination meter.

NG >> Replace BCM. Refer to [BCS-28, "Removal and Installation of BCM"](#).

DATA MONITOR	
MONITOR	
OIL W/L	ON

PKIA2064E

WARNING LAMPS

5. CHECK OIL PRESSURE SWITCH CIRCUIT

1. Turn ignition switch OFF.
2. Disconnect the IPDM E/R connector and the oil pressure switch connector.
3. Check continuity between IPDM E/R harness connector E9 terminal 57 (BR) and oil pressure switch harness connector F1 terminal 1 (BR).

Continuity should exist.

OK or NG

- OK >> GO TO 6.
NG >> Repair harness or connector.

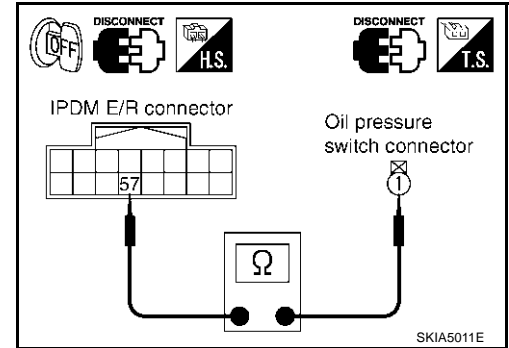

6. CHECK OIL PRESSURE SWITCH

Check oil pressure switch. Refer to [DI-67, "OIL PRESSURE SWITCH"](#) .

OK or NG

- OK >> Replace IPDM E/R. Refer to [PG-45, "Removal and Installation of IPDM E/R"](#) .
NG >> Replace oil pressure switch.

Oil Pressure Warning Lamp Does Not Turn Off (Oil Pressure Is Normal)

AKS005NG

NOTE:

For oil pressure inspection, refer to [LU-8, "OIL PRESSURE CHECK"](#) .

1. CHECK IPDM E/R OUTPUT SIGNAL

1. Disconnect the oil pressure switch connector.
2. Turn ignition switch ON.
3. Check voltage between oil pressure switch harness connector F1 terminal 1 (BR) and ground.

Approx. 12V

OK or NG

- OK >> GO TO 2.
NG >> GO TO 3.

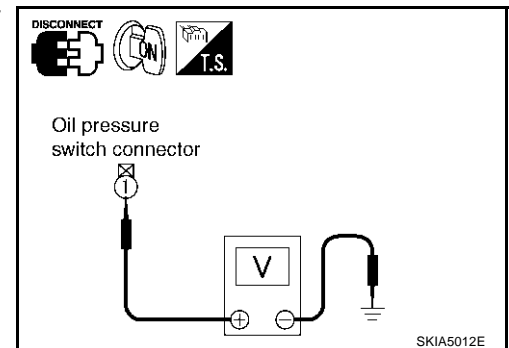

2. CHECK OIL PRESSURE SWITCH

1. Turn ignition switch OFF.
2. Check oil pressure switch. Refer to [DI-67, "OIL PRESSURE SWITCH"](#) .

OK or NG

- OK >> Replace IPDM E/R.
NG >> Replace oil pressure switch.

WARNING LAMPS

3. CHECK OIL PRESSURE SWITCH CIRCUIT

1. Disconnect the IPDM E/R connector.
2. Check continuity between IPDM E/R harness connector E9 terminal 57 (BR) and ground.

Continuity should not exist.

OK or NG

- OK >> Replace IPDM E/R.
 NG >> Repair harness or connector.

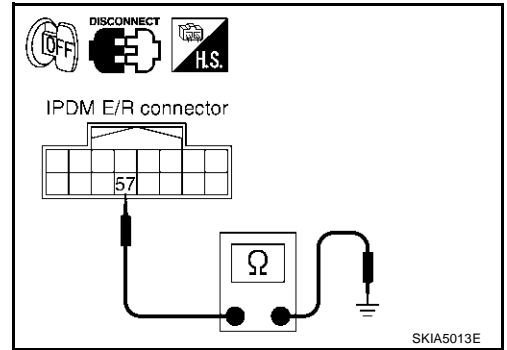

AKS005NH

Component Inspection OIL PRESSURE SWITCH

Check continuity between oil pressure switch and ground.

Condition	Oil pressure kPa (kg/cm ² , psi)	Continuity
Engine stopped	Less than 29 (0.3, 4)	Yes
Engine running	More than 29 (0.3, 4)	No

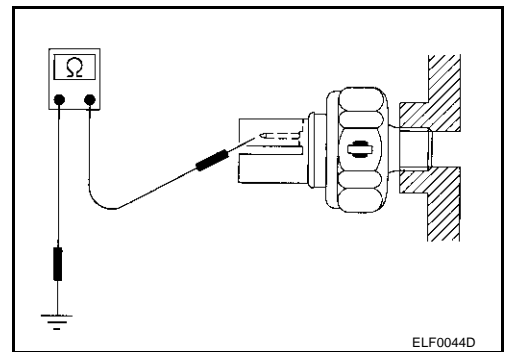

A
B
C
D
E
F
G
H
I
J
DI
L
M

DI

A/T INDICATOR

PFP:24814

AKS005NI

DI-AT/IND-01

▬ : DATA LINE

A/T INDICATOR

Wiring Diagram — AT/IND —

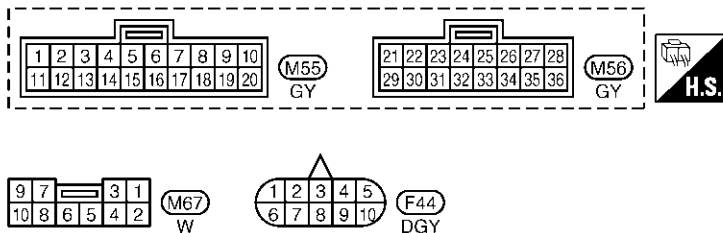
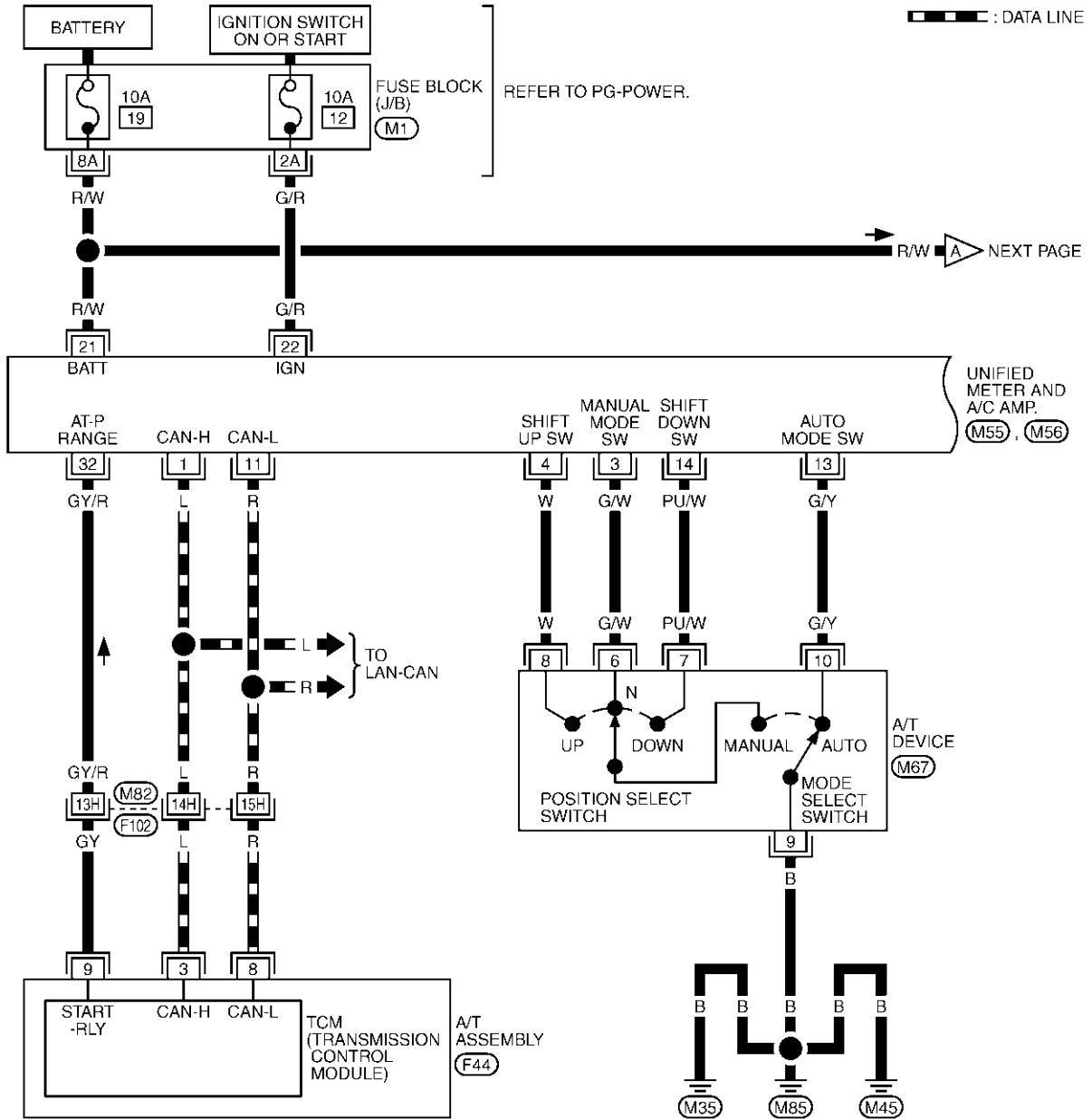

REFER TO THE FOLLOWING.

- (F102) -SUPER MULTIPLE JUNCTION (SMJ)
- (M1) -FUSE BLOCK-JUNCTION BOX (J/B)

TKWM0693E

A/T INDICATOR

DI-AT/IND-02

A
B
C
D
E
F
G
H
I
J
K
L
M

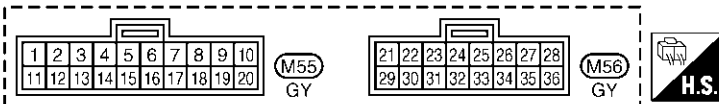
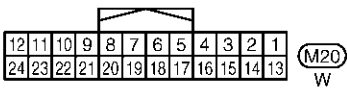
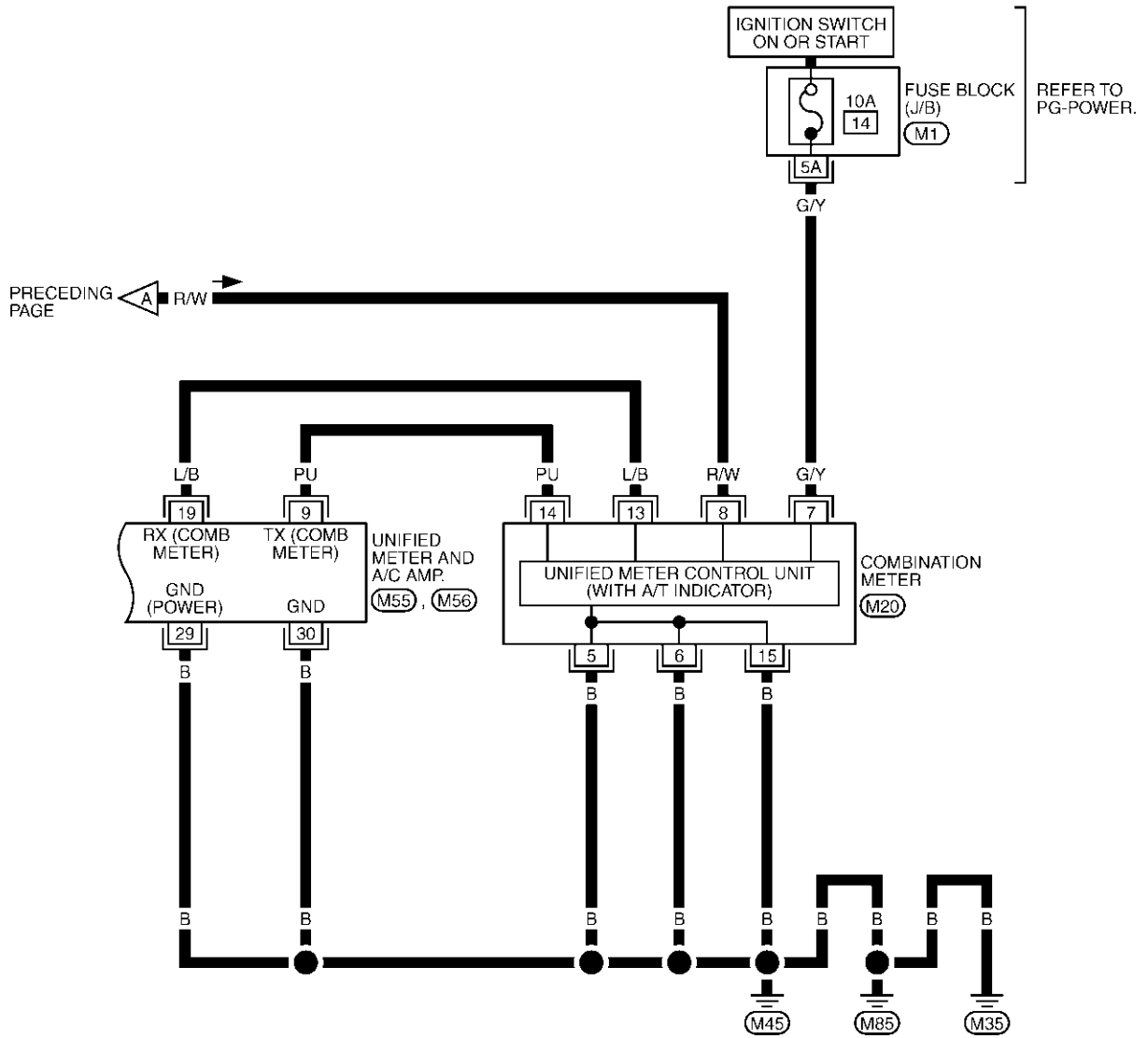

REFER TO THE FOLLOWING.
 (M1) - FUSE BLOCK-JUNCTION BOX (J/B)

TKWM0694E

A/T INDICATOR

AKS005NJ

A/T Indicator Is Malfunction

1. CHECK SELF-DIAGNOSIS OF COMBINATION METER

Perform combination meter self-diagnosis. Refer to [DI-13, "HOW TO ALTERNATE DIAGNOSIS MODE"](#).

Are all segments displayed?

- YES >> GO TO 2.
- NO >> Replace combination meter.

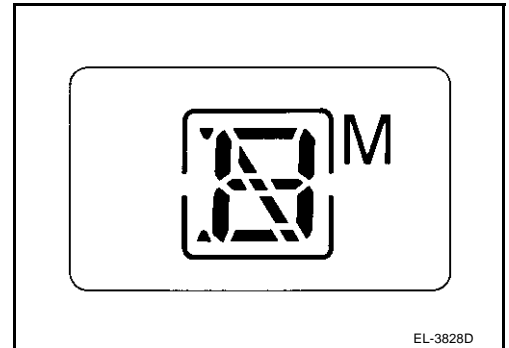

2. CHECK SELF-DIAGNOSIS RESULTS OF UNIFIED METER AND A/C AMP.

1. Start engine.
2. Select "METER A/C AMP" on CONSULT-II, and perform self-diagnosis of unified meter and A/C amp. Refer to [DI-48, "CONSULT-II Function"](#).
3. After erasing the self-diagnostic results, perform self-diagnosis again.

Self-diagnostic results content

- No malfunction detected>> GO TO 3.
- Malfunction detected>> Go to [DI-18, "Symptom Chart 2"](#) in "COMBINATION METER".

3. CHECK UNIFIED METER AND A/C AMP. INPUT SIGNAL

1. Lift up drive wheels.
2. Connect CONSULT-II and start engine.
3. Select "DATA MONITOR" of "METER A/C AMP". Operate each switch with "DATA MONITOR" of "AT-M IND", "AT-M GEAR", "P RANGE IND", "R RANGE IND", "N RANGE IND" and "D RANGE IND" and check operation status of applicable switches.

CONSULT-II display	Switch operation	Operation status
AT-M IND	Manual mode range	ON
	Except for manual mode range	OFF
AT-M GEAR	Manual mode range (shift- up or down)	5-1
	Except for manual mode range	1
P RANGE IND	P range position	ON
	Except for P range position	OFF
R RANGE IND	R range position	ON
	Except for R range position	OFF
N RANGE IND	N range position	ON
	Except for N range position	OFF
D RANGE IND	D range position	ON
	Except for D range position	OFF

DATA MONITOR	
MONITOR	
AT-M IND	OFF
AT-M GEAR	1
P RANGE IND	ON
R RANGE IND	OFF
N RANGE IND	OFF
D RANGE IND	OFF

SKIA6259E

OK or NG

- OK >> Replace combination meter.
- NG >> GO TO 4.

A/T INDICATOR

4. CHECK A/T DEVICE

Perform A/T device inspection. Refer to [AT-178, "DTC P1815 MANUAL MODE SWITCH"](#) in AT section.

OK or NG

OK >> GO TO 5.

NG >> Repair the applicable parts.

5. CHECK TCM

Check TCM input/output signal. Refer to [AT-107, "TCM Input/Output Signal Reference Values"](#) in AT section.

OK or NG

OK >> Replace unified meter and A/C amp. Refer to [DI-51, "Removal and Installation of Unified Meter and A/C Amp."](#)

NG >> Check the applicable parts.

A

B

C

D

E

F

G

H

I

J

DI

L

M

WARNING CHIME

PFP:24814

WARNING CHIME

Component Parts and Harness Connector Location

AKS005NK

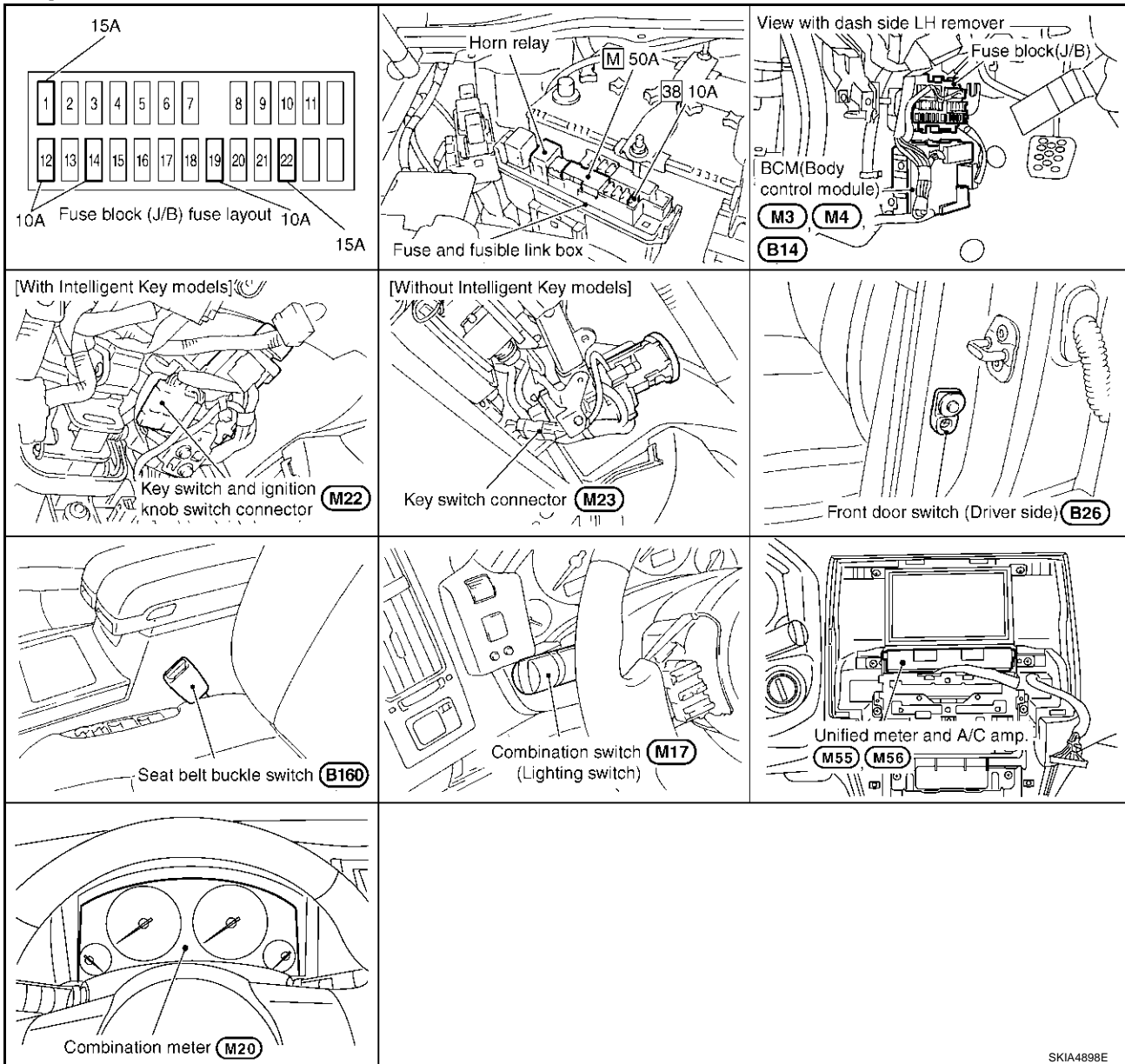

SKIA4898E

System Description

FUNCTION

AKS005NL

Power is supplied at all times

- through 50A fusible link (letter **M** , located in the fuse and fusible link box)
- to BCM terminal 55
- through 15A fuse [No. 22, located in the fuse block (J/B)]
- to key switch terminal 2 (without Intelligent Key),
- to key switch and ignition knob switch terminal 3 (with Intelligent Key), and
- to BCM terminal 42
- through 10A fuse [No. 38, located in the fuse and fusible link box] (with Intelligent Key)
- to key switch and ignition knob switch terminals 1
- through 10A fuse [No. 19, located in the fuse block (J/B)]
- to unified meter and A/C amp. terminal 21, and
- to combination meter terminal 8.

WARNING CHIME

When ignition switch ON or START position, power is supplied

- through 15A fuse [No. 1, located in the fuse block (J/B)]
- to BCM terminal 38, and
- through 10A fuse [No. 12, located in the fuse block (J/B)]
- to unified meter and A/C amp. terminal 22
- through 10A fuse [No. 14, located in the fuse block (J/B)]
- to combination meter terminal 7.

Ground is supplied

- to BCM terminals 49 and 52, and
- to unified meter and A/C amp. terminals 29 and 30, and
- to combination meter terminals 5, 6 and 15
- through body grounds M35, M45 and M85.

NOTE:

When ignition key warning chime, light warning chime, and seat belt warning chime should be performed at the same time, the priorities for each chime are the following.

1. Seat belt warning chime
2. Light warning chime
3. Ignition key warning chime

IGNITION KEY WARNING CHIME (WITHOUT INTELLIGENT KEY)

With the key inserted into the ignition switch, and the ignition switch OFF or ACC, when driver's door open, the warning chime will sound.

Power is supplied

- through key switch terminal 1
- to BCM terminal 37.

Ground is supplied

- to BCM terminal 62
- through front door switch (driver side) terminal 1.

Front door switch (driver side) is case grounded.

BCM detects key inserted into the ignition switch, and sends key warning signal to unified meter and A/C amp. with CAN communication line. Unified meter and A/C amp. sends key warning signal to combination meter with communication line between unified meter and A/C amp. and combination meter.

When combination meter receives key warning signal, it sounds warning chime.

IGNITION KEY WARNING CHIME (WITH INTELLIGENT KEY)

When Mechanical Key Is Used

With the key inserted into the ignition switch, and the ignition switch LOCK or ACC, when driver's door open, the warning chime will sound.

Power is supplied

- through key switch and ignition knob switch terminal 4
- to BCM terminal 37.

Ground is supplied

- to BCM terminal 62
- through front door switch (driver side) terminal 1.

Front door switch (driver side) is case grounded.

BCM detects key inserted into the ignition switch, and sends key warning signal to unified meter and A/C amp. with CAN communication line. Unified meter and A/C amp. sends key warning signal to combination meter with communication line between unified meter and A/C amp. and combination meter.

When combination meter receives key warning signal, it sounds warning chime.

When Intelligent Key Is Carried With The Driver

With the ignition knob is in LOCK (push switch ON) or ACC, when driver's door open, the warning chime will sound.

Power is supplied

A

B

C

D

E

F

G

H

I

J

DI

L

M

WARNING CHIME

- through key switch and ignition knob switch terminal 2
- to Intelligent Key unit terminal 27.

Ground is supplied

- to BCM terminal 62
- through front door switch (driver side) terminal 1.

Front door switch (driver side) is case grounded.

BCM sends front door switch signal to Intelligent Key unit with CAN communication line.

Intelligent Key unit detects ignition knob return is forgotten, and sends key warning signal to unified meter and A/C amp. with CAN communication line. Unified meter and A/C amp. sends key warning signal to combination meter with communication line between unified meter and A/C amp. and combination meter.

When combination meter receives key warning signal, it sounds warning chime.

LIGHT WARNING CHIME

With the key removed from the ignition switch or with the ignition knob is in LOCK (push switch OFF) [with Intelligent Key], the driver's door open, and the lighting switch in ON position, the warning chime will sound. [Except when headlamp battery saver control operates (for 5 minutes after ignition switch is turned to OFF or ACC position) and headlamps do not illuminate.]

Signal is supplied

- from combination switch (lighting switch) terminals 1, 2, 3, 4, 5, 6, 7, 8, 9 and 10
- to BCM terminals 2, 3, 4, 5, 6, 32, 33, 34, 35 and 36.

NOTE:

BCM detected lighting switch in 1st or 2nd position, refer to [BCS-3, "COMBINATION SWITCH READING FUNCTION"](#).

Ground is supplied

- to BCM terminal 62
- through front door switch (driver side) terminal 1.

Front door switch (driver side) is case grounded.

BCM detects headlamps are illuminated, and sends light warning signal to unified meter and A/C amp. with CAN communication line. Unified meter and A/C amp. sends light warning signal to combination meter with communication line between unified meter and A/C amp. and combination meter.

When combination meter receives light warning signal, it sounds warning chime.

SEAT BELT WARNING CHIME

With ignition switch turned ON and seat belt unfastened [seat belt buckle switch (driver side) ON], warning chime will sound for approximately 6 seconds.

Ground is supplied

- to combination meter terminal 9
- through seat belt buckle switch (driver side) terminal 60.

Seat belt buckle switch (driver side) terminal 61A is grounded through body grounds B15 and B45.

Combination meter sends seat belt unfastened [seat belt buckle switch (driver side) ON] signal to unified meter and A/C amp. with communication line between unified meter and A/C amp. and combination meter.

BCM receives seat belt unfastened [seat belt buckle switch (driver side) ON] signal from unified meter and A/C amp. with CAN communication line, and sends seat belt warning signal to unified meter and A/C amp. with CAN communication line. Unified meter and A/C amp. sends seat belt warning signal to combination meter with communication line between unified meter and A/C amp. and combination meter.

When combination meter receives seat belt warning signal, it sounds warning chime.

WARNING CHIME

CAN Communication System Description

AKS007ZZ

CAN (Controller Area Network) is a serial communication line for real time application. It is an on-vehicle multiplex communication line with high data communication speed and excellent error detection ability. Many electronic control units are equipped onto a vehicle, and each control unit shares information and links with other control units during operation (not independent). In CAN communication, control units are connected with 2 communication lines (CAN H line, CAN L line) allowing a high rate of information transmission with less wiring. Each control unit transmits/receives data but selectively reads required data only.

CAN Communication Unit

AKS007YY

Body type	Wagon					
	2WD			AWD		
Axle	VQ35DE			VQ35DE/VK45DE		
Engine	VQ35DE			VQ35DE/VK45DE		
Transmission	A/T					
Brake control	VDC					
Navigation system			×			×
Low tire pressure warning system			×			×
ICC system			×			×
Intelligent Key system			×			×
Automatic drive positioner		×	×		×	×
CAN communication unit						
ECM	×	×	×	×	×	×
TCM	×	×	×	×	×	×
Display unit	×	×		×	×	
Display control unit			×			×
Low tire pressure warning control unit			×			×
AWD control unit				×	×	×
ICC unit			×			×
Intelligent Key unit			×			×
Data link connector	×	×	×	×	×	×
BCM	×	×	×	×	×	×
Steering angle sensor	×	×	×	×	×	×
Unified meter and A/C amp.	×	×	×	×	×	×
ICC sensor			×			×
ABS actuator and electric unit (control unit)	×	×	×	×	×	×
Driver seat control unit		×	×		×	×
IPDM E/R	×	×	×	×	×	×
CAN communication type	DI-76. "TYPE 1/TYPE2"		DI-79. "TYPE 3"	DI-82. "TYPE 4/TYPE5"		DI-85. "TYPE 6"

×: Applicable

WARNING CHIME

TYPE 1/TYPE2 System Diagram

- Type1

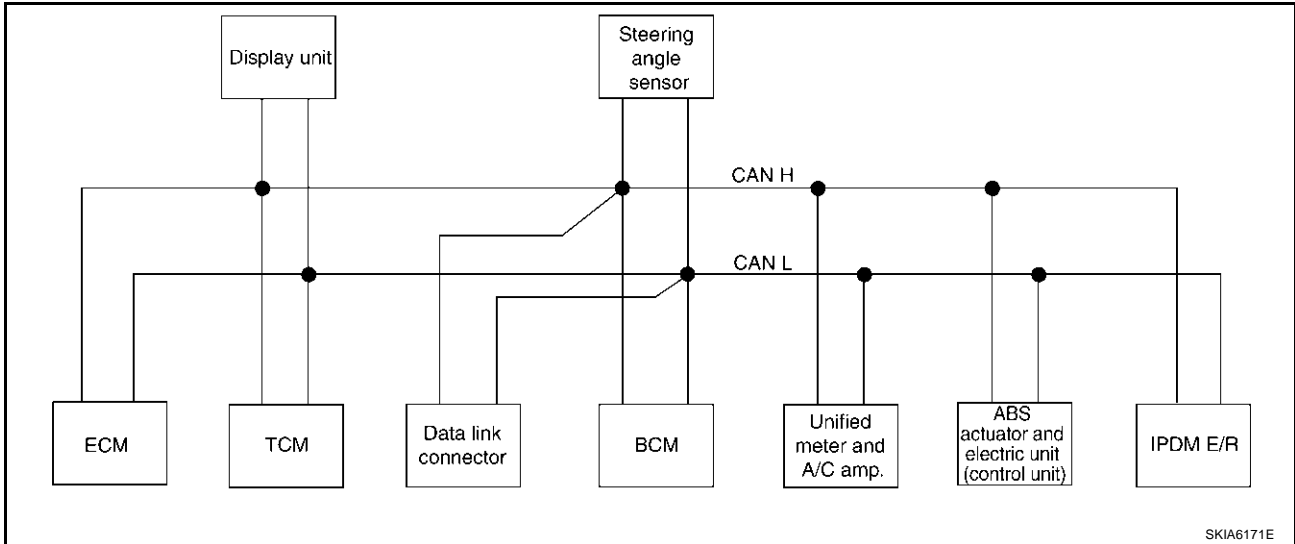

- Type2

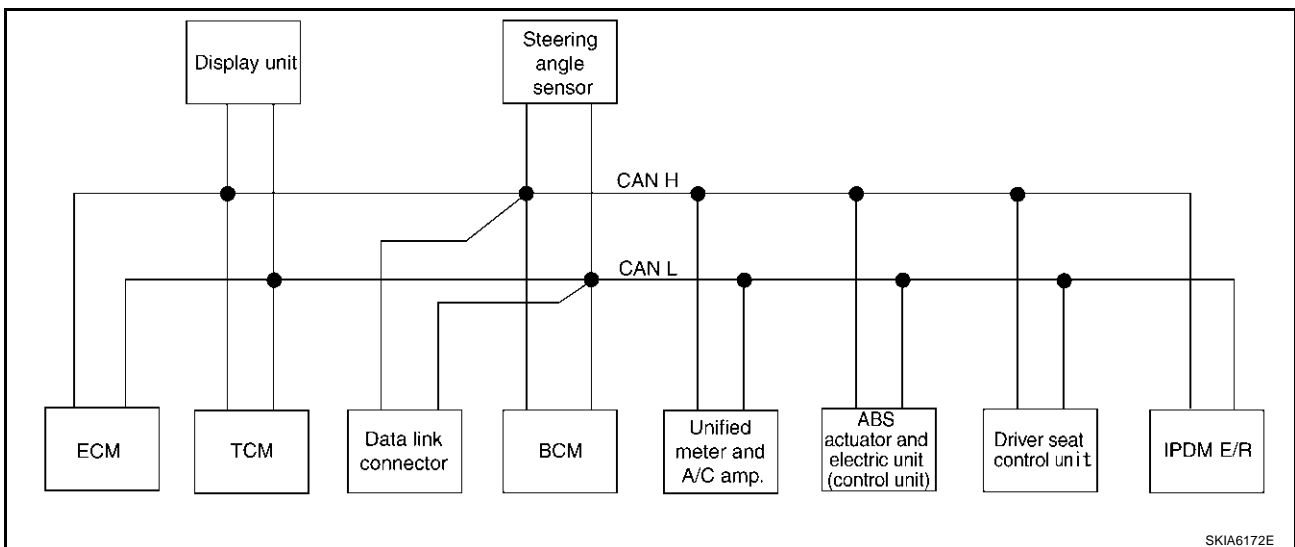

Input/output Signal Chart

T: Transmit R: Receive

Signals	ECM	TCM	Display unit	BCM	Steering angle sensor	Unified meter and A/C amp.	ABS actuator and electric unit (control unit)	Driver seat control unit	IPDM E/R
Engine speed signal	T	R	R			R	R		
Engine status signal	T			R					
Engine coolant temperature signal	T	R				R			
A/T self-diagnosis signal	R	T							
Accelerator pedal position signal	T	R					R		
Closed throttle position signal	T	R							
Wide open throttle position signal	T	R							

WARNING CHIME

Signals	ECM	TCM	Display unit	BCM	Steering angle sensor	Unified meter and A/C amp.	ABS actuator and electric unit (control unit)	Driver seat control unit	IPDM E/R
Battery voltage signal	T	R							
Key switch signal				T				R	
Ignition switch signal				T				R	R
P range signal		T					R	R	
Stop lamp switch signal		R				T			
ABS operation signal	R						T		
TCS operation signal	R						T		
VDC operation signal	R						T		
Fuel consumption monitor signal	T		R			R			
Input shaft revolution signal	R	T							
Output shaft revolution signal	R	T							
A/C switch signal	R			T					
A/C compressor request signal	T								R
A/C relay status signal	R								T
A/C compressor feedback signal	T					R			
Blower fan motor switch signal	R			T					
A/C control signal			T			R			
			R			T			
Cooling fan speed request signal	T								R
Cooling fan speed signal	R								T
Position light request signal			R	T		R			R
Low beam request signal				T					R
Low beam status signal	R								T
High beam request signal				T		R			R
High beam status signal	R								T
Front fog light request signal				T					R
Day time running light request signal				T		R			
Turn LED burnout status signal				R		T			
Vehicle speed signal						R	T		
	R	R	R	R		T		R	
Sleep wake up signal				T		R		R	R
Door switch signal			R	T		R		R	R
Turn indicator signal				T		R			
Key fob ID signal				T				R	
Key fob door unlock signal				T				R	
Oil pressure switch signal				R					T
				T		R			
Buzzer output signal				T		R			
Fuel level sensor signal	R					T			
Fuel level low warning signal			R			T			

A
B
C
D
E
F
G
H
I
J
L
M

DI

WARNING CHIME

Signals	ECM	TCM	Display unit	BCM	Steering angle sensor	Unified meter and A/C amp.	ABS actuator and electric unit (control unit)	Driver seat control unit	IPDM E/R
ASCD operation signal	T	R							
ASCD OD cancel request	T	R							
Front wiper request signal				T					R
Front wiper stop position signal				R					T
Rear window defogger switch signal				T					R
Rear window defogger control signal	R		R	R					T
Hood switch signal				R					T
Theft warning horn request signal				T					R
Horn chirp signal				T					R
Steering angle sensor signal					T		R		
ABS warning lamp signal						R	T		
VDC OFF indicator lamp signal						R	T		
SLIP indicator lamp signal						R	T		
Brake warning lamp signal						R	T		
System setting signal			T	R				R	
A/T CHECK indicator lamp signal		T				R			
A/T position indicator lamp signal		T				R			
A/T shift schedule change demand signal		R					T		
Manual mode signal		R				T			
Not manual mode signal		R				T			
Manual mode shift up signal		R				T			
Manual mode shift down signal		R				T			
Manual mode indicator signal		T				R			
Distance to empty signal			R			T			
Hand brake switch				R		T			

WARNING CHIME

TYPE 3

System Diagram

- Type3

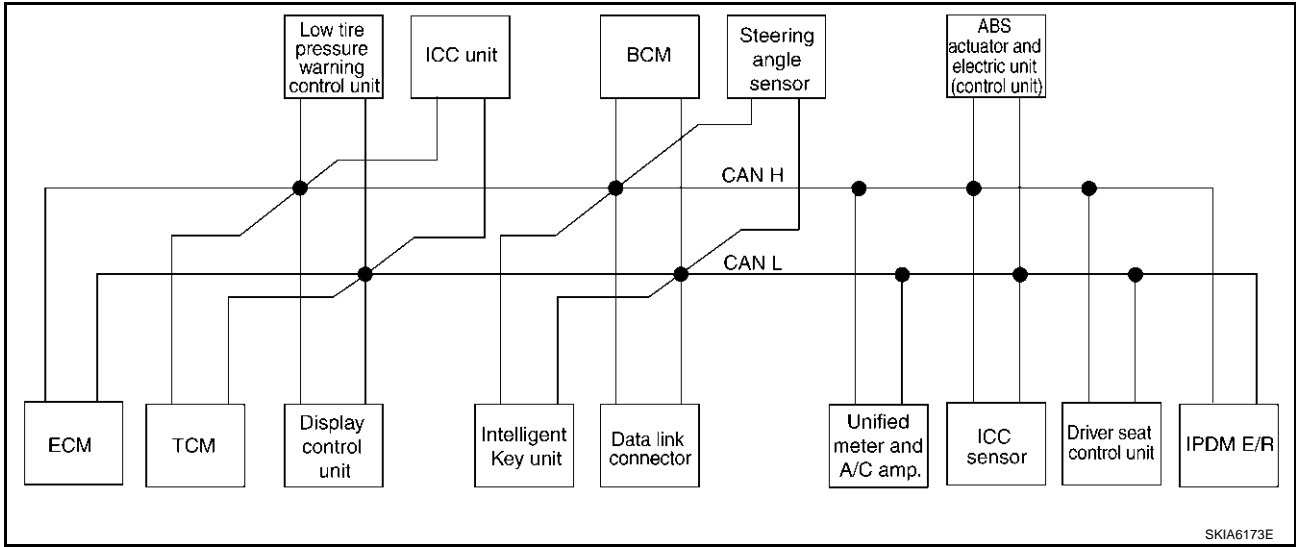

Input/output Signal Chart

T: Transmit R: Receive

Signals	ECM	TCM	Display control unit	Low tire pressure warning control unit	ICC unit	Intelligent Key unit	BCM	Steering angle sensor	Unified meter and A/C amp.	ICC sensor	ABS actuator and electric unit (control unit)	Driver seat control unit	IPDM E/R
Engine speed signal	T	R	R		R				R		R		
Engine status signal	T						R						
Engine coolant temperature signal	T	R			R				R				
A/T self-diagnosis signal	R	T											
Accelerator pedal position signal	T	R			R						R		
Closed throttle position signal	T	R			R								
Wide open throttle position signal	T	R											
Battery voltage signal	T	R											
Key switch signal							T					R	
Ignition switch signal							T					R	R
P range signal		T			R						R	R	
Stop lamp switch signal		R							T				
ABS operation signal	R				R						T		
TCS operation signal	R				R						T		
VDC operation signal	R				R						T		
Fuel consumption monitor signal	T		R						R				

WARNING CHIME

Signals	ECM	TCM	Display control unit	Low tire pressure warning control unit	ICC unit	Intelligent Key unit	BCM	Steering angle sensor	Unified meter and A/C amp.	ICC sensor	ABS actuator and electric unit (control unit)	Driver seat control unit	IPDM E/R
Input shaft revolution signal	R	T			R								
Output shaft revolution signal	R	T			R								
A/C switch signal	R						T						
A/C compressor request signal	T												R
A/C relay status signal	R												T
A/C compressor feedback signal	T								R				
Blower fan motor switch signal	R						T						
A/C control signal			T						R				
			R						T				
Cooling fan speed signal	R												T
Position light request signal	R						T		R				R
Low beam request signal							T						R
Low beam status signal	R												T
High beam request signal							T		R				R
High beam status signal	R												T
Front fog light request signal							T						R
Day time running light request signal							T		R				
Turn LED burnout status signal							R		T				
Vehicle speed signal					R				R		T		
	R	R	R	R		R	R		T	R		R	
Sleep wake up signal							T		R			R	R
						T	R						
Door switch signal			R			R	T		R			R	R
Turn indicator signal							T		R				
Key fob ID signal							T					R	
Key fob door unlock signal							T					R	
Oil pressure switch signal							R						T
							T		R				
Buzzer output signal							T		R				
						T			R				
					T				R				

WARNING CHIME

Signals	ECM	TCM	Display control unit	Low tire pressure warning control unit	ICC unit	Intelligent Key unit	BCM	Steering angle sensor	Unified meter and A/C amp.	ICC sensor	ABS actuator and electric unit (control unit)	Driver seat control unit	IPDM E/R
Fuel level sensor signal	R								T				
Fuel level low warning signal			R						T				
ICC operation signal	R				T								
Front wiper request signal					R		T						R
Front wiper stop position signal							R						T
Rear window defogger switch signal							T						R
Rear window defogger control signal	R		R				R						T
Hood switch signal							R						T
Theft warning horn request signal							T						R
Horn chirp signal							T						R
Steering angle sensor signal								T			R		
Tire pressure signal				T					R				
Tire pressure data signal			R	T									
ABS warning lamp signal					R				R		T		
VDC OFF indicator lamp signal					R				R		T		
SLIP indicator lamp signal									R		T		
Brake warning lamp signal									R		T		
System setting signal			T			R						R	
Distance to empty signal			R						T				
Hand brake switch signal							R		T				
Door lock/unlock request signal						T	R						
Door lock/unlock status signal						R	T						
Starter permission signal						T	R						
Back door open request signal						T	R						
Power window open request signal						T	R						
Alarm request signal						T	R						
Key warning signal						T			R				
ICC sensor signal					R					T			
ICC warning lamp signal					T				R				

A
B
C
D
E
F
G
H
I
J
DI
L
M

WARNING CHIME

Signals	ECM	TCM	Display control unit	Low tire pressure warning control unit	ICC unit	Intelligent Key unit	BCM	Steering angle sensor	Unified meter and A/C amp.	ICC sensor	ABS actuator and electric unit (control unit)	Driver seat control unit	IPDM E/R
ICC system display signal					T				R				
Current gear position signal		T			R						R		
Steering switch signal	T				R								
ASCD operation signal	T	R											
ASCD OD cancel request	T	R											
ICC OD cancel request	R	R			T								
A/T CHECK indicator lamp signal		T							R				
A/T position indicator lamp signal		T							R				
A/T shift schedule change demand signal		R									T		
Manual mode signal		R							T				
Not manual mode signal		R							T				
Manual mode shift up signal		R							T				
Manual mode shift down signal		R							T				
Manual mode indicator signal		T			R				R				
Ignition knob switch signal						T	R						

TYPE 4/TYPE5

System Diagram

- Type4

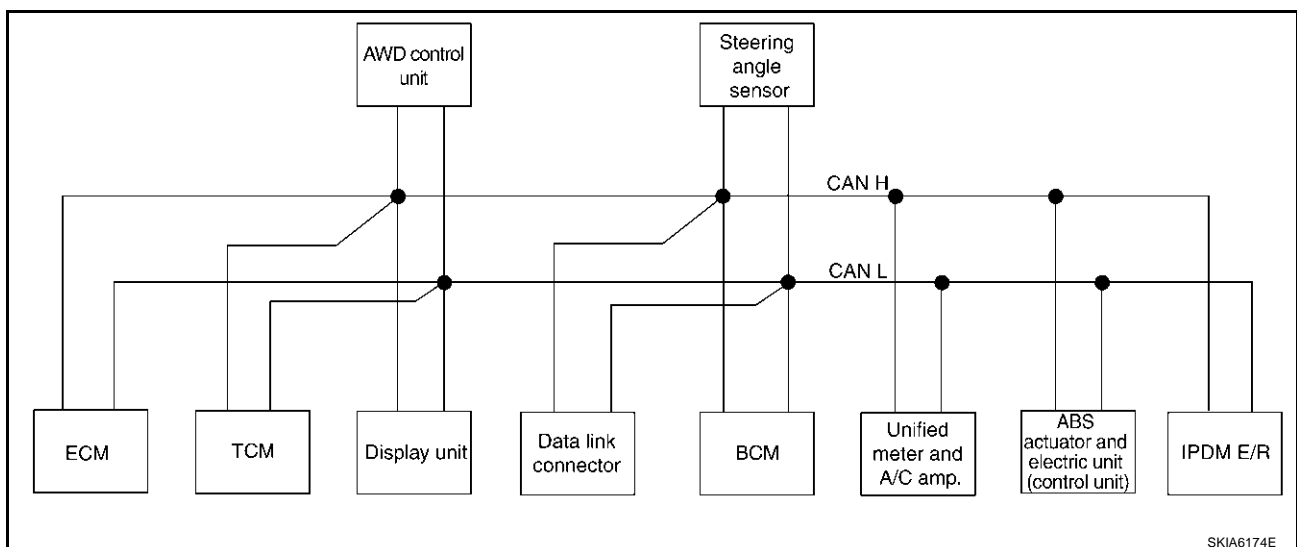

WARNING CHIME

● Type5

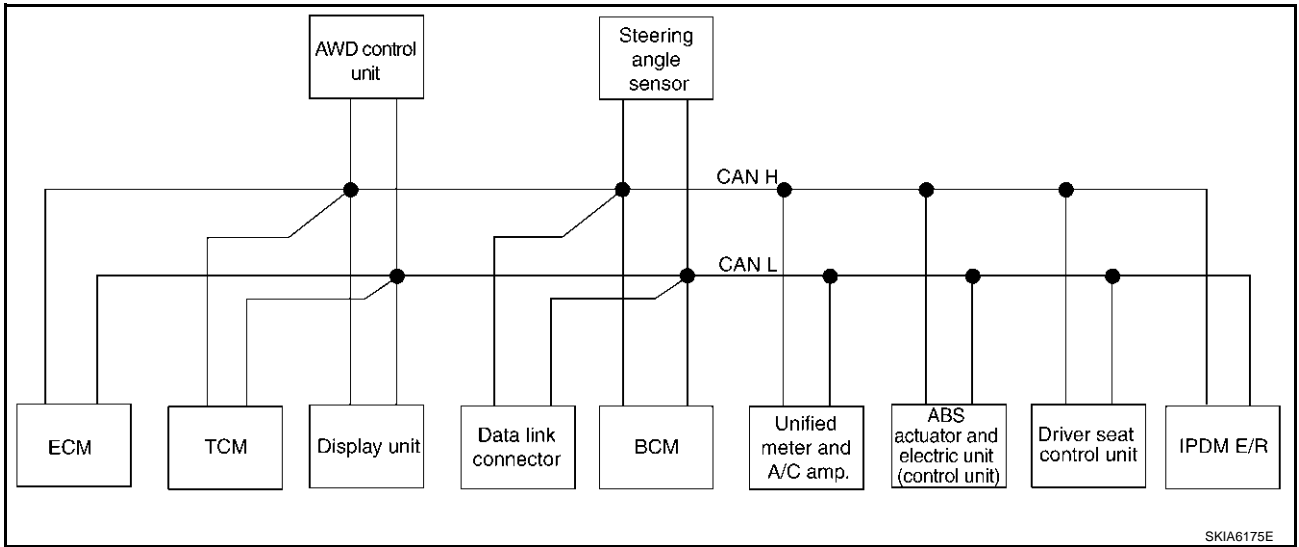

Input/output Signal Chart

T: Transmit R: Receive

Signals	ECM	TCM	Display unit	AWD control unit	BCM	Steering angle sensor	Unified meter and A/C amp.	ABS actuator and electric unit (control unit)	Driver seat control unit	IPDM E/R
A/T self-diagnosis signal	R	T								
ABS operation signal	R			R				T		
TCS operation signal	R							T		
VDC operation signal	R			R				T		
Stop lamp switch signal		R		R			T			
Battery voltage signal	T	R								
Key switch signal					T				R	
Ignition switch signal					T				R	R
P range signal		T						R	R	
Closed throttle position signal	T	R								
Wide open throttle position signal	T	R								
Engine speed signal	T	R	R	R			R	R		
Engine status signal	T				R					
Engine coolant temperature signal	T	R					R			
Accelerator pedal position signal	T	R		R				R		
Fuel consumption monitor signal	T		R				R			
Input shaft revolution signal	R	T								
Output shaft revolution signal	R	T								
A/C switch signal	R				T					
A/C compressor request signal	T									R
A/C relay status signal	R									T
A/C compressor feedback signal	T						R			

A
B
C
D
E
F
G
H
I
J
DI
L
M

WARNING CHIME

Signals	ECM	TCM	Display unit	AWD control unit	BCM	Steering angle sensor	Unified meter and A/C amp.	ABS actuator and electric unit (control unit)	Driver seat control unit	IPDM E/R
Blower fan motor switch signal	R				T					
A/C control signal			T				R			
			R				T			
Cooling fan speed signal	R									T
Position light request signal			R		T		R			R
Low beam request signal					T					R
Low beam status signal	R									T
High beam request signal					T		R			R
High beam status signal	R									T
Front fog light request signal					T					R
Day time running light request signal					T		R			
Turn LED burnout status signal					R		T			
Vehicle speed signal							R	T		
	R	R	R		R		T		R	
Sleep wake up signal					T		R		R	R
Door switch signal			R		T		R		R	R
Turn indicator signal					T		R			
Key fob ID signal					T				R	
Key fob door unlock signal					T				R	
Oil pressure switch signal					R					T
					T		R			
Buzzer output signal					T		R			
Fuel level sensor signal	R						T			
Fuel level low warning signal			R				T			
Front wiper request signal					T					R
Front wiper stop position signal					R					T
Rear window defogger switch signal					T					R
Rear window defogger control signal	R		R		R					T
Hood switch signal					R					T
Theft warning horn request signal					T					R
Horn chirp signal					T					R
Steering angle sensor signal						T		R		
ABS warning lamp signal							R	T		
VDC OFF indicator lamp signal							R	T		
SLIP indicator lamp signal							R	T		
Brake warning lamp signal							R	T		
System setting signal			T		R				R	
AWD warning lamp signal				T			R			

WARNING CHIME

Signals	ECM	TCM	Display unit	AWD control unit	BCM	Steering angle sensor	Unified meter and A/C amp.	ABS actuator and electric unit (control unit)	Driver seat control unit	IPDM E/R
AWD lock indicator lamp signal				T			R			
Distance to empty signal			R				T			
Hand brake switch signal				R	R		T			
ASCD operation signal	T	R								
ASCD OD cancel request	T	R								
A/T CHECK indicator lamp signal		T					R			
A/T position indicator lamp signal		T					R			
A/T shift schedule change demand signal		R						T		
Manual mode signal		R					T			
Not manual mode signal		R					T			
Manual mode shift up signal		R					T			
Manual mode shift down signal		R					T			
Manual mode indicator signal		T					R			

TYPE 6

System Diagram

- Type6

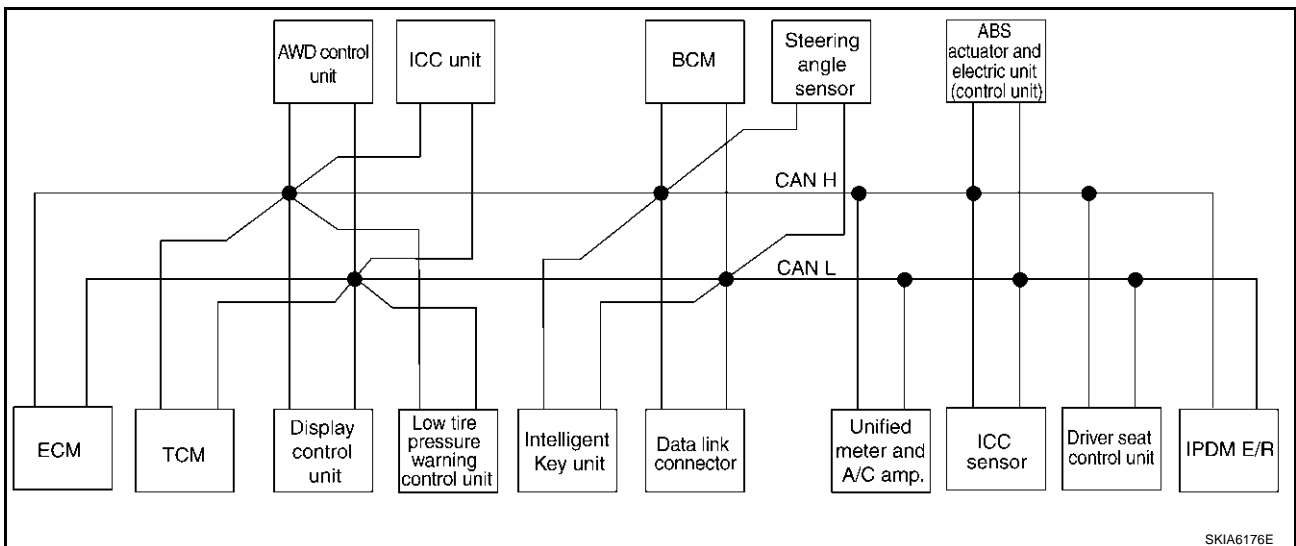

WARNING CHIME

Input/output Signal Chart

T: Transmit R: Receive

Signals	ECM	TCM	Display control unit	Low tire pressure warning control unit	AWD control unit	ICC unit	Intelligent Key unit	BCM	Steering angle sensor	Unified meter and A/C amp.	ICC sensor	ABS actuator and electric unit (control unit)	Driver seat control unit	IPD M E/R
A/T self-diagnosis signal	R	T												
ABS operation signal	R				R	R						T		
TCS operation signal	R					R						T		
VDC operation signal	R				R	R					R	T		
Stop lamp switch signal		R			R					T				
Battery voltage signal	T	R												
Key switch signal								T					R	
Ignition switch signal								T					R	R
P range signal		T				R						R	R	
Closed throttle position signal	T	R				R								
Wide open throttle position signal	T	R												
Engine speed signal	T	R	R		R	R				R		R		
Engine status signal	T							R						
Engine coolant temperature signal	T	R				R				R				
Accelerator pedal position signal	T	R			R	R						R		
Fuel consumption monitor signal	T		R							R				
A/T self-diagnosis signal	R	T												
Input shaft revolution signal	R	T				R								
Output shaft revolution signal	R	T				R								
A/C switch signal	R							T						
A/C compressor request signal	T													R
A/C relay status signal	R													T
A/C compressor feedback signal	T									R				
Blower fan motor switch signal	R							T						
A/C control signal			T							R				
			R							T				
Cooling fan speed signal	R													T
Position light request signal			R					T		R				R
Low beam request signal								T						R
Low beam status signal	R													T
High beam request signal								T		R				R

WARNING CHIME

Signals	ECM	TCM	Display control unit	Low tire pressure warning control unit	AWD control unit	ICC unit	Intelligent Key unit	BCM	Steering angle sensor	Unified meter and A/C amp.	ICC sensor	ABS actuator and electric unit (control unit)	Driver seat control unit	IPD M E/ R
High beam status signal	R													T
Front fog light request signal								T						R
Day time running light request signal								T		R				
Turn LED burnout status signal								R		T				
Vehicle speed signal						R				R		T		
	R	R	R	R			R	R		T	R		R	
Sleep wake up signal								T		R			R	R
							T	R						
Door switch signal			R				R	T		R			R	R
Key fob ID signal								T					R	
Key fob door unlock signal								T					R	
Oil pressure switch signal								R						T
								T		R				
Buzzer output signal							T			R				
						T				R				
Fuel level sensor signal	R									T				
Fuel level low warning signal			R							T				
ICC operation signal	R					T								
Front wiper request signal						R		T						R
Front wiper stop position signal								R						T
Rear window defogger switch signal								T						R
Rear window defogger control signal	R		R					R						T
Hood switch signal								R						T
Theft warning horn request signal								T						R
Horn chirp signal								T						R
Steering angle sensor signal									T			R		
Tire pressure signal				T						R				
Tire pressure data signal			R	T										
ABS warning lamp signal						R				R		T		
VDC OFF indicator lamp signal						R				R		T		
SLIP indicator lamp signal										R		T		

A
B
C
D
E
F
G
H
I
J
L
M

DI

WARNING CHIME

Signals	ECM	TCM	Display control unit	Low tire pressure warning control unit	AWD control unit	ICC unit	Intelligent Key unit	BCM	Steering angle sensor	Unified meter and A/C amp.	ICC sensor	ABS actuator and electric unit (control unit)	Driver seat control unit	IPD M E/R
Brake warning lamp signal										R		T		
System setting signal			T				R						R	
AWD warning lamp signal					T					R				
AWD lock indicator lamp signal					T					R				
Distance to empty signal			R							T				
Hand brake switch signal					R			R		T				
Door lock/unlock request signal							T	R						
Door lock/unlock status signal							R	T						
Starter permission signal							T	R						
Back door open request signal							T	R						
Power window open request signal							T	R						
Alarm request signal							T	R						
Key warning signal							T			R				
ICC sensor signal						R					T			
ICC warning lamp signal						T				R				
ICC system display signal						T				R				
Current gear position signal		T				R						R		
Steering switch signal	T					R								
ASCD operation signal	T	R												
ASCD OD cancel request	T	R												
ICC OD cancel request	R	R				T								
A/T CHECK indicator lamp signal		T								R				
A/T position indicator lamp signal		T								R				
A/T shift schedule change demand signal		R										T		
Manual mode signal		R								T				
Not manual mode signal		R								T				
Manual mode shift up signal		R								T				
Manual mode shift down signal		R								T				
Manual mode indicator signal		T								R				
Ignition knob switch signal							T	R						

WARNING CHIME

Schematic

AKS0069H

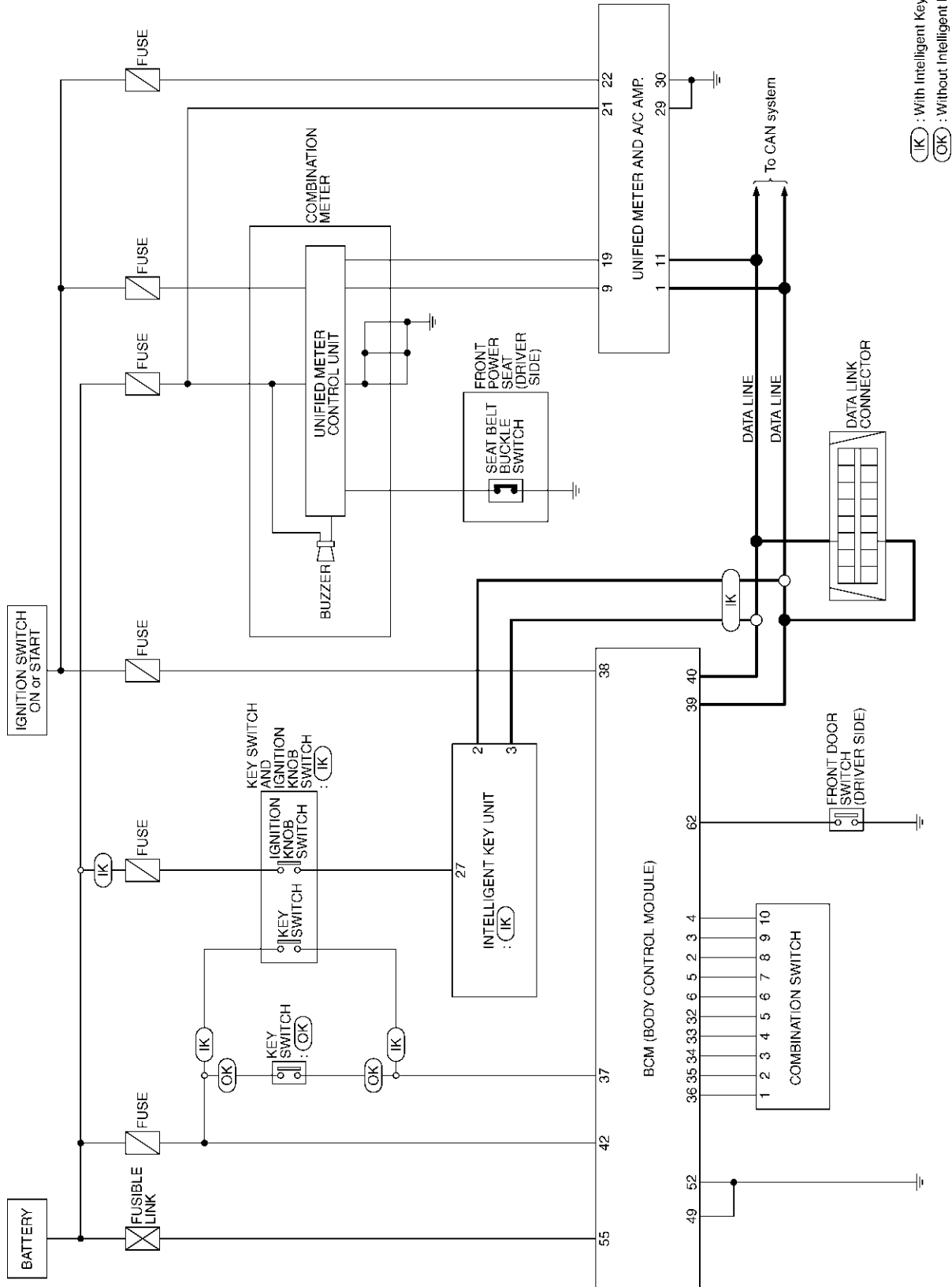

TKWM0812E

A
B
C
D
E
F
G
H
I
J
DI
L
M

WARNING CHIME

AKS005NN

Wiring Diagram — CHIME —

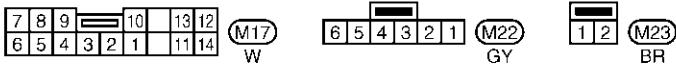
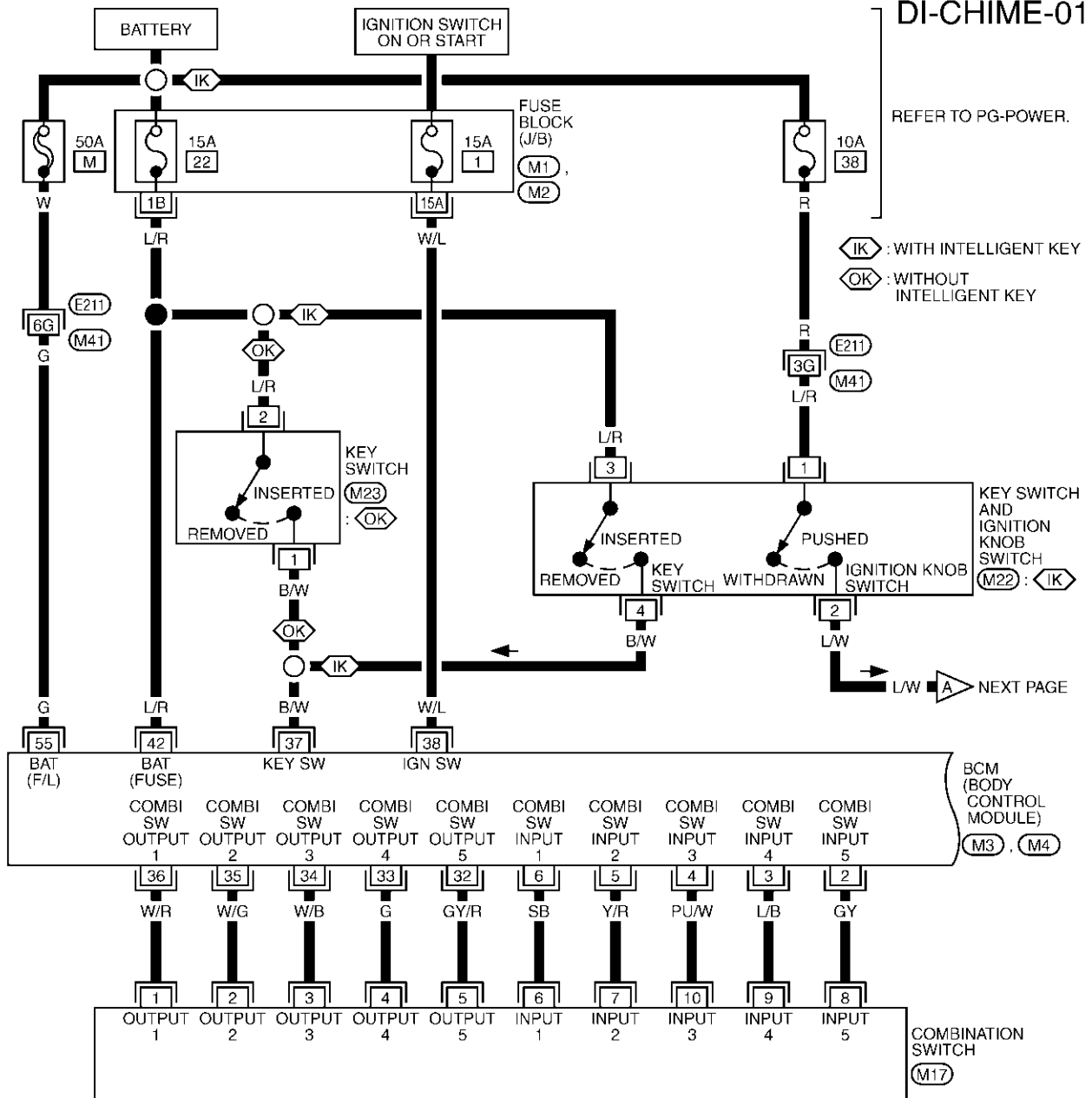

REFER TO THE FOLLOWING.

- (E21) - SUPER MULTIPLE JUNCTION (SMJ)
- (M1), (M2) - FUSE BLOCK-JUNCTION BOX (J/B)
- (M3), (M4) - ELECTRICAL UNITS

TKWM0813E

WARNING CHIME

DI-CHIME-02

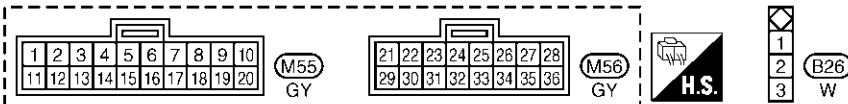
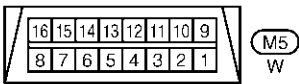
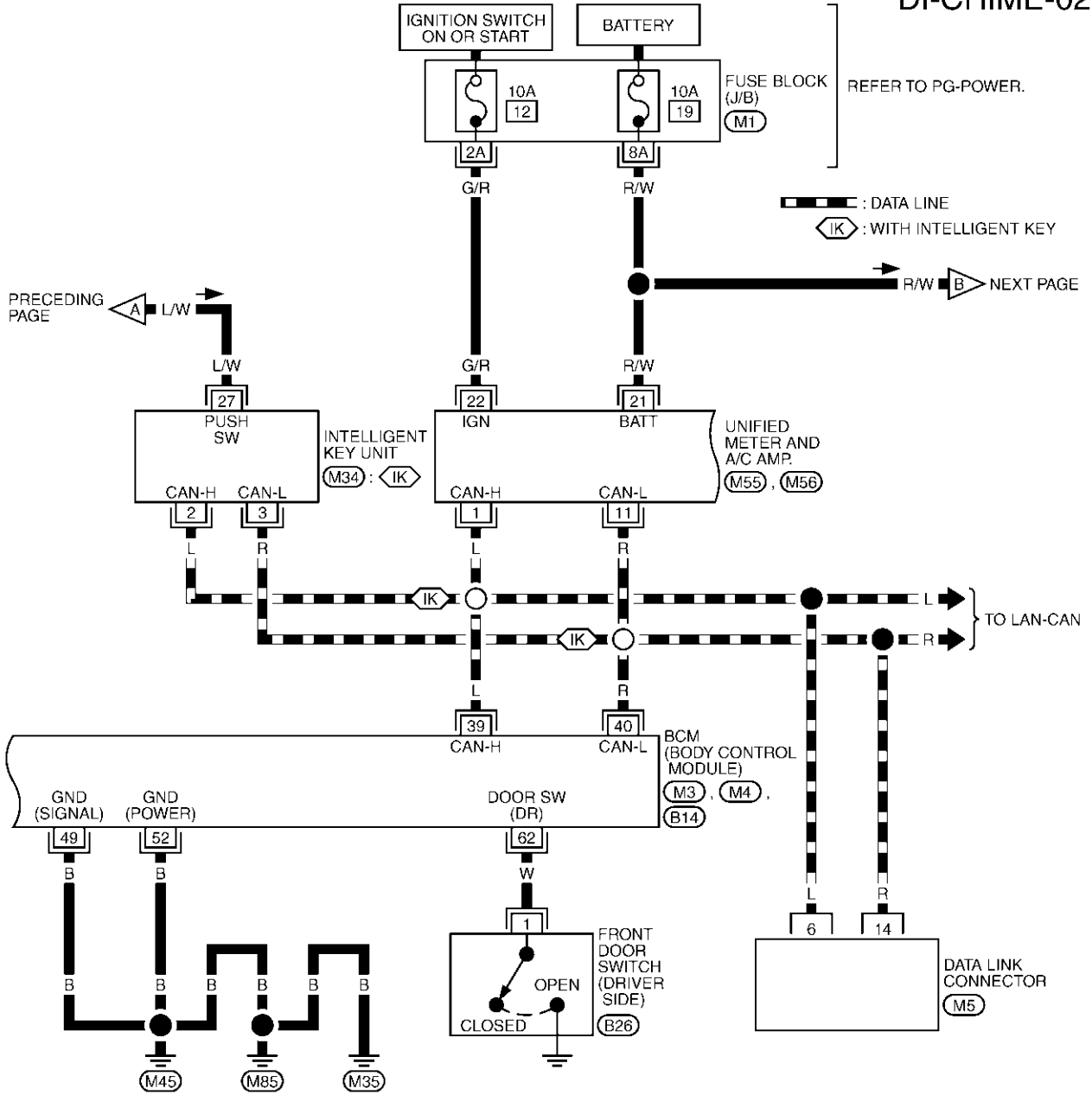

REFER TO THE FOLLOWING.

- (M1) - FUSE BLOCK-JUNCTION BOX (J/B)
- (M3), (M4), (M34), (B14) - ELECTRICAL UNITS

TKWM0697E

WARNING CHIME

DI-CHIME-03

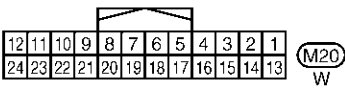
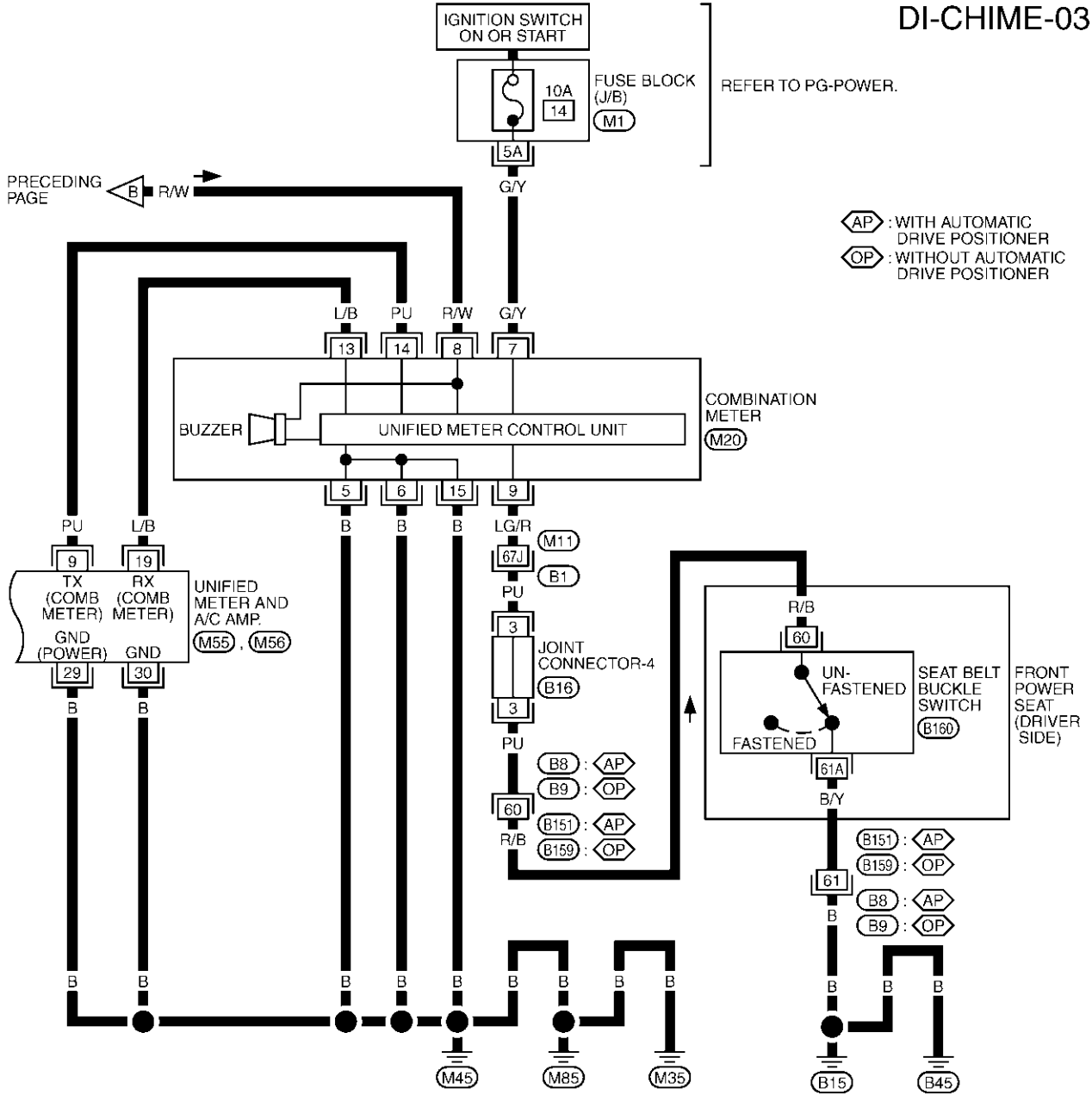

*: THIS CONNECTOR IS NOT SHOWN IN "HARNESS LAYOUT", PG SECTION.

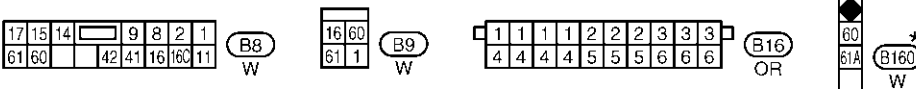
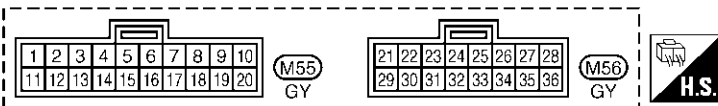

REFER TO THE FOLLOWING.



- (B1) -SUPER MULTIPLE JUNCTION (SMJ)
- (M1) -FUSE BLOCK-JUNCTION BOX (J/B)

TKWM0698E

WARNING CHIME

Terminals and Reference Value for BCM

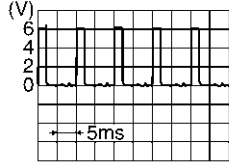
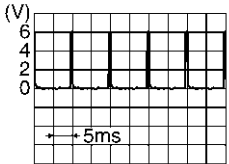
AKS005NO

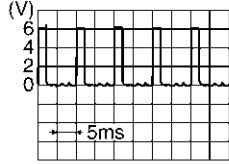
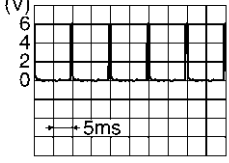
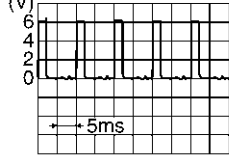
Terminal No.	Wire color	Item	Measuring condition		Reference value
			Ignition switch	Operation or condition	
2	GY	Combination switch input 5	ON	Lighting, turn, wiper OFF Wiper dial position 4	 <p style="text-align: right;">SKIA5291E</p>
3	L/B	Combination switch input 4	ON	Lighting, turn, wiper OFF Wiper dial position 4	 <p style="text-align: right;">SKIA5292E</p>
4	PU/W	Combination switch input 3	ON	Lighting, turn, wiper OFF Wiper dial position 4	 <p style="text-align: right;">SKIA5291E</p>
5	Y/R	Combination switch input 2	ON	Lighting, turn, wiper OFF Wiper dial position 4	 <p style="text-align: right;">SKIA5292E</p>
6	SB	Combination switch input 1			
32	GY/R	Combination switch output 5	ON	Lighting, turn, wiper OFF Wiper dial position 4	 <p style="text-align: right;">SKIA5291E</p>
33	G	Combination switch output 4	ON	Lighting, turn, wiper OFF Wiper dial position 4	 <p style="text-align: right;">SKIA5292E</p>
34	W/B	Combination switch output 3	ON	Lighting, turn, wiper OFF Wiper dial position 4	 <p style="text-align: right;">SKIA5291E</p>

A
B
C
D
E
F
G
H
I
J
DI
L
M

WARNING CHIME

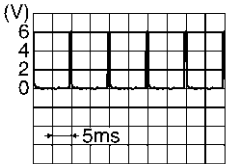
Terminal No.	Wire color	Item	Measuring condition		Reference value
			Ignition switch	Operation or condition	
35	W/G	Combination switch output 2	ON	Lighting, turn, wiper OFF Wiper dial position 4	 <small>SKIA5292E</small>
36	W/R	Combination switch output 1			
37	B/W	Key switch signal	OFF	Key is removed	Approx. 0V
				Key is inserted	Approx. 12V
38	W/L	Ignition switch ON or START	ON	—	Battery voltage
39	L	CAN H	OFF	—	—
40	R	CAN L	OFF	—	—
42	L/R	Battery power supply	OFF	—	Battery voltage
49	B	Ground	ON	—	Approx. 0V
52					
55	G	Battery power supply	OFF	—	Battery voltage
62	W	Front door switch (driver side)	OFF	When driver side door is opened [Door switch ON]	Approx. 0V
				When driver side door is closed [Door switch OFF]	Approx. 12V

Terminals and Reference Value for Unified Meter and A/C Amp.

AKS005NP

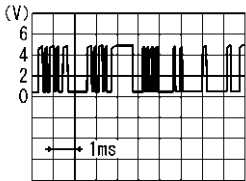
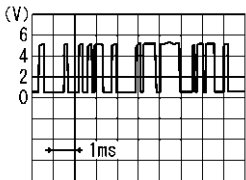
Terminal No.	Wire color	Item	Measuring condition		Reference value
			Ignition switch	Operation or condition	
1	L	CAN H	OFF	—	—
9	PU	TX communication line (To combination meter)	ON	—	 <small>SKIA3362E</small>
11	R	CAN L	OFF	—	—
19	L/B	RX communication line (From combination meter)	ON	—	 <small>SKIA3361E</small>
21	R/W	Battery power supply	OFF	—	Battery voltage
22	G/R	Ignition switch ON or START	ON	—	Battery voltage
29	B	Ground (power)	ON	—	Approx. 0V
30	B	Ground	ON	—	Approx. 0V

WARNING CHIME

Terminals and Reference Value for Combination Meter

AKS005NQ

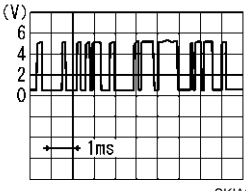
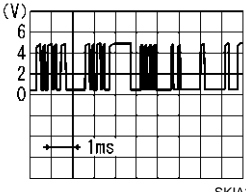
Terminal No.	Wire color	Item	Measuring condition		Reference value
			Ignition switch	Operation or condition	
5	B	Ground	ON	—	Approx. 0V
6	B	Ground	ON	—	Approx. 0V
7	G/Y	Ignition switch ON or START	ON	—	Battery voltage
8	R/W	Battery power supply	OFF	—	Battery voltage
9	LG/R	Seat belt buckle switch (driver side)	ON	Unfastened (ON)	Approx. 0V
				Fastened (OFF)	Approx. 12V
13	L/B	TX communication line (To unified meter and A/C amp.)	ON	—	
14	PU	RX communication line (From unified meter and A/C amp.)	ON	—	
15	B	Ground	ON	—	Approx. 0V

How to Proceed With Trouble Diagnosis

AKS005NR

1. Confirm the malfunction symptom or customer complaint.
2. Understand operation description and function description. Refer to [DI-72, "System Description"](#) .
3. Perform the Preliminary Check. Refer to [DI-96, "Preliminary Check"](#) .
4. Start engine.
5. Select "METER A/C AMP" on CONSULT-II, and perform self-diagnosis of unified meter and A/C amp. Refer to [DI-48, "CONSULT-II Function"](#) .
6. After erasing the self-diagnostic results, perform self-diagnosis again. When no malfunction detected, go to next step 7. When malfunction detected, go to [DI-18, "Symptom Chart 2"](#) in "COMBINATION METER".
7. Check symptom and repair or replace the cause of malfunction.
8. Does the warning chime operate normally? If so, go to 9. If not, go to 7.
9. INSPECTION END

WARNING CHIME

AKS005NS

Preliminary Check CHECK POWER SUPPLY AND GROUND CIRCUIT

1. CHECK FUSE AND FUSIBLE LINK

Check BCM fuses and fusible link for blown-out.

Unit	Power source	Fuse and fusible link No.
BCM	Battery	M
		22
	Ignition switch ON or START	1

Refer to [DI-90, "Wiring Diagram — CHIME —"](#) .

OK or NG

OK >> GO TO 2.

NG >> If fuse or fusible link is blown, be sure to eliminate cause of malfunction before installing new fuse or fusible link. Refer to [PG-3, "POWER SUPPLY ROUTING CIRCUIT"](#) .

2. CHECK POWER SUPPLY CIRCUIT

1. Disconnect BCM connector.
2. Check voltage between BCM harness connector terminals and ground.

Terminals		(-)	Ignition switch position		
(+)	Terminal (Wire color)		OFF	ACC	ON
M4	55 (G)	Ground	Battery voltage	Battery voltage	Battery voltage
	42 (L/R)		Battery voltage	Battery voltage	Battery voltage
M3	38 (W/L)		0V	0V	Battery voltage

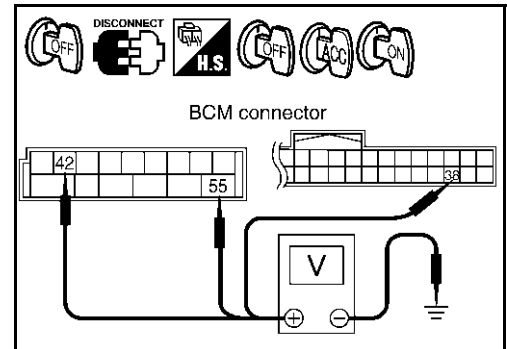

OK or NG

OK >> GO TO 3.

NG >> Check harness for open between BCM and fuse or fusible link.

3. CHECK GROUND CIRCUIT

1. Turn ignition switch OFF.
2. Check continuity between BCM harness connector M4 terminals 49 (B), 52 (B) and ground.

Continuity should exist.

OK or NG

OK >> INSPECTION END

NG >> Repair harness or connector.

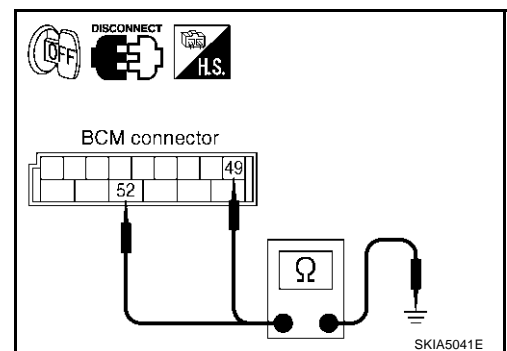

WARNING CHIME

CONSULT-II Function

AKS005NT

CONSULT-II executes the following functions by combining data reception and command transmission via the communication line from BCM. Work support, self-diagnosis, data monitor, and active test display.

DIAGNOSTIC ITEMS DESCRIPTION

BCM diagnosis position	Diagnosis mode	Description
BUZZER	Data monitor	The input data to the BCM control unit is displayed in real time.
	Active test	Operation of electrical loads can be checked by sending driving signal to them.
BCM	Self-diagnostic	BCM performs self-diagnosis of CAN communication.

CONSULT-II BASIC OPERATION PROCEDURE

CAUTION:

If CONSULT-II is used with no connection of CONSULT-II CONVERTER, malfunctions might be detected in self-diagnosis depending on control unit which carry out CAN communication.

1. With the ignition switch OFF, connect "CONSULT-II" and "CONSULT-II CONVERTER" to the data link connector, and turn the ignition switch ON.

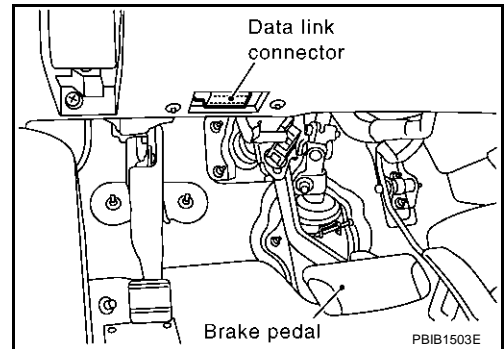

2. Touch "START (NISSAN BASED VHCL)".

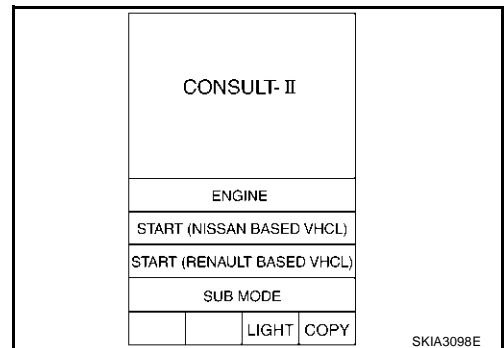

3. Touch "BCM" on "SELECT SYSTEM" screen. If "BCM" is not indicated, go to [LAN-4, "Precautions When Using CONSULT-II"](#)

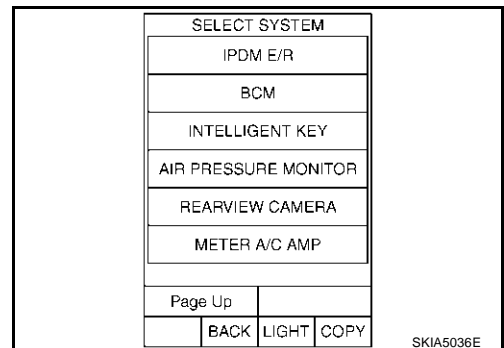

WARNING CHIME

4. Touch "BUZZER" or "BCM".
5. Select "DATA MONITOR" or "SELF-DIAG RESULTS".

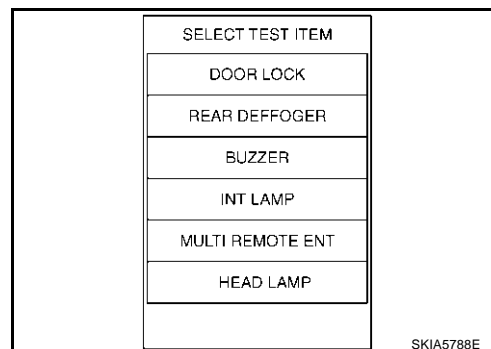

DATA MONITOR

Operation Procedure

1. Touch "BUZZER" on "SELECT TEST ITEM" screen.
2. Touch "DATA MONITOR" on "SELECT DIAG MODE" screen.
3. Touch "ALL SIGNALS" or "SELECTION FROM MENU" on "DATA MONITOR" screen.

ALL SIGNALS	Monitors main items.
SELECTION FROM MENU	Selects and monitors items.

4. If "SELECTION FROM MENU" is selected, touch the desired monitor item. If "ALL SIGNALS" is selected, all items required to control are monitored.
5. Touch "START".
6. During monitoring, touching "RECORD" can start recording the monitored item status.

Data Monitor Item

Monitored item	Description
IGN ON SW	Indicates [ON/OFF] condition of ignition switch.
KEY ON SW	Indicates [ON/OFF] condition of key switch.
DOOR SW-DR	Indicates [ON/OFF] condition of front door switch (driver side).
TAIL LAMP SW	Indicates [ON/OFF] condition of lighting switch.

ACTIVE TEST

Operation Procedure

1. Touch "BUZZER" on "SELECT TEST ITEM" screen.
2. Touch "ACTIVE TEST" on "SELECT DIAG MODE" screen.
3. Touch the item to be tested, and check the operation.
4. During the operation check, touching "OFF" deactivates the operation.

Active Test Item

Test item	Malfunction is detected when...
LIGHT WARN ALM	This test is able to check light warning chime operation. Light warning chime sounds for 2 seconds after touching "ON" on CONSULT-II screen.
IGN KEY WARN ALM	This test is able to check key warning chime operation. Key warning chime sounds for 2 seconds after touching "ON" on CONSULT-II screen.
SEAT BELT WARN ALM	This test is able to check seat belt warning chime operation. Seat belt warning chime sounds for 2 seconds after touching "ON" on CONSULT-II screen.

SELF-DIAGNOSTIC RESULTS

Operation Procedure

1. Touch "BCM" on "SELECT TEST ITEM" screen.
2. Touch "SELF-DIAG RESULTS" on "SELECT DIAG MODE" screen.
3. Self-diagnostic results are displayed.

WARNING CHIME

Display Item List

Monitored Item	CONSULT-II display	Description
CAN communication	CAN communication [U1000]	Malfunction is detected in CAN communication.
CAN communication system	CAN communication system 1 to 6 [U1000]	Malfunction is detected in CAN system.

NOTE:

If "CAN communication [U1000]" is indicated, after printing the monitor item, go to "CAN system". Refer to [LAN-4, "Precautions When Using CONSULT-II"](#) .

All Warnings Are Not Operated

AKS005NU

1. CHECK CHIME OPERATION

Select "BUZZER" on CONSULT-II, and perform "LIGHT WARN ALM", "IGN KEY WARN ALM" or "SEAT BELT WARN" of "ACTIVE TEST".

Does chime sound?

- YES >> Replace BCM. Refer to [BCS-28, "Removal and Installation of BCM"](#) .
- NO >> GO TO 2.

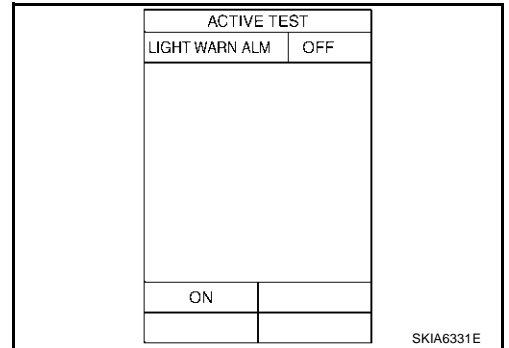

2. CHECK UNIFIED METER AND A/C AMP. INPUT SIGNAL

Select "METER A/C AMP" on CONSULT-II. Operate switches meet the requirements to sounds warning chime with "BUZZER" of "DATA MONITOR" and check operation status.

When meet the requirements to sounds warning chime : BUZZER ON

Except above : BUZZER OFF

OK or NG

- OK >> Replace combination meter.
- NG >> Replace BCM. Refer to [BCS-28, "Removal and Installation of BCM"](#) .

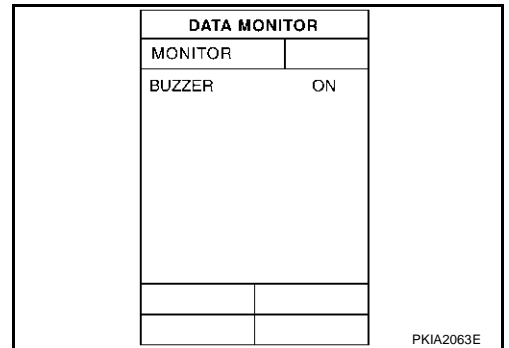

A
B
C
D
E
F
G
H
I
J
DI
L
M

WARNING CHIME

Key Warning Chime and Light Warning Chime Does Not Operate (Seat Belt Warning Chime Does Operate)

AKS005NV

1. CHECK BCM INPUT SIGNAL

Ⓟ With CONSULT-II

1. Select "BCM".
2. With "DATA MONITOR" of "BUZZER", confirm "DOOR SW-DR" when the driver side door is operated.

When driver side door is opened : DOOR SW-DR ON

When driver side door is closed : DOOR SW-DR OFF

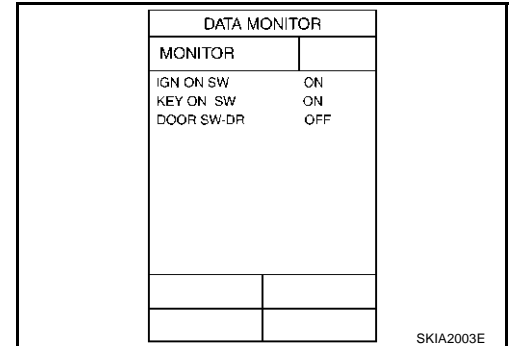

ⓧ Without CONSULT-II

Check voltage between BCM harness connector B14 terminal 62 (W) and ground.

When driver side door is opened : Approx. 0V

When driver side door is closed : Approx. 12V

OK or NG

- OK >> Replace BCM. Refer to [BCS-28, "Removal and Installation of BCM"](#).
- NG >> GO TO 2.

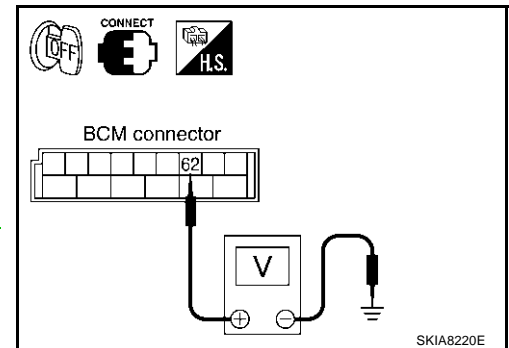

2. CHECK FRONT DOOR SWITCH (DRIVER SIDE) CIRCUIT

1. Turn ignition switch OFF.
2. Disconnect BCM connector and front door switch (driver side) connector.
3. Check continuity between BCM harness connector B14 terminal 62 (W) and front door switch (driver side) harness connector B26 terminal 1 (W).

Continuity should exist.

4. Check continuity between BCM harness connector B14 terminal 62 (W) and ground.

Continuity should not exist.

OK or NG

- OK >> GO TO 3.
- NG >> Repair harness or connector.

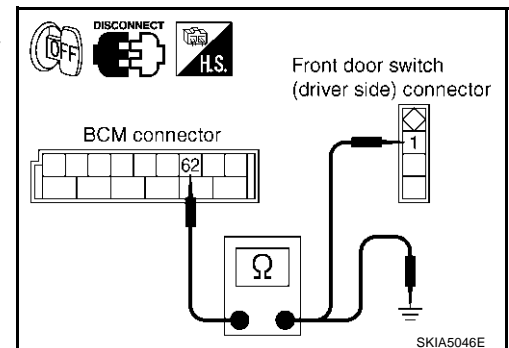

WARNING CHIME

3. CHECK FRONT DOOR SWITCH (DRIVER SIDE)

Check front door switch (driver side).

When driver side door switch is released : Continuity should exist.

When driver side door switch is pushed : Continuity should not exist.

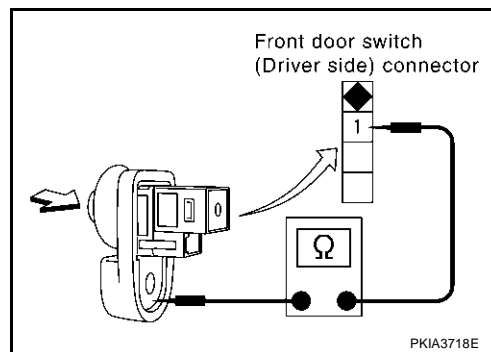

OK or NG

OK >> Replace BCM. Refer to [BCS-28, "Removal and Installation of BCM"](#).

NG >> Replace front door switch (driver side).

Key Warning Chime Does Not Operate (Without Intelligent Key)

1. CHECK FUSE

Check if the key switch 15A fuse [No. 22, located in the fuse block (J/B)] is blown. Refer to [DI-90, "Wiring Diagram — CHIME —"](#).

Is the fuse blown?

YES >> Replace fuse. Be sure to repair the cause of malfunction before installing new fuse.

NO >> GO TO 2.

2. CHECK WARNING CHIME OPERATION

Check the chime under conditions in exception of key warning chime (without Intelligent Key) operation.

Does warning chime sound?

YES >> GO TO 3.

NO >> Go to [DI-99, "All Warnings Are Not Operated"](#) or [DI-100, "Key Warning Chime and Light Warning Chime Does Not Operate \(Seat Belt Warning Chime Does Operate\)"](#).

WARNING CHIME

3. CHECK BCM INPUT SIGNAL

With CONSULT-II

1. Select "BCM".
2. With "DATA MONITOR" of "BUZZER", confirm "KEY ON SW" when the key is operated.

When key is inserted to ignition key cylinder : KEY ON SW ON

When key is removed from ignition key cylinder : KEY ON SW OFF

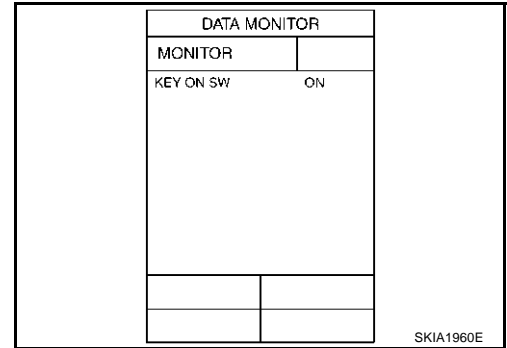

Without CONSULT-II

Check voltage between BCM harness connector M3 terminal 37 (B/W) and ground.

When key is inserted to ignition key cylinder : Approx. 12V

When key is removed from ignition key cylinder : Approx. 0V

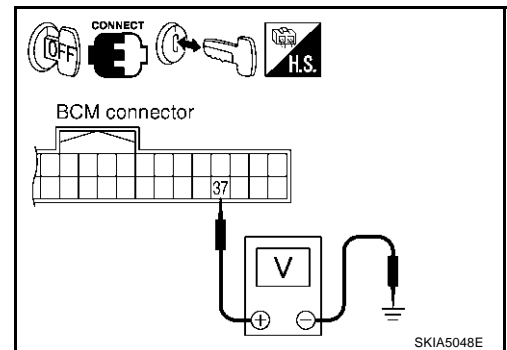

OK or NG

- OK >> Replace BCM. Refer to [BCS-28, "Removal and Installation of BCM"](#).
- NG >> GO TO 4.

4. CHECK KEY SWITCH

1. Disconnect key switch.
2. Check continuity between key switch connector M23 terminals 1 and 2.

When key is inserted to ignition key cylinder : Continuity should exist

When key is removed from ignition key cylinder : Continuity should not exist.

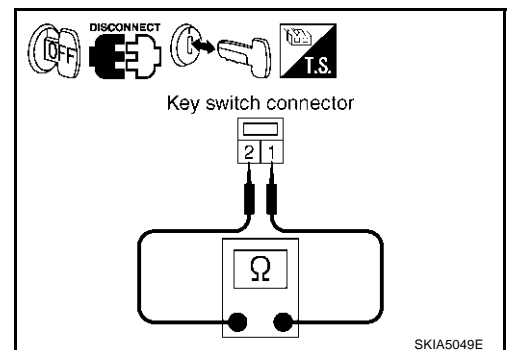

OK or NG

- OK >> GO TO 5.
- NG >> Replace key switch.

WARNING CHIME

5. CHECK KEY SWITCH CIRCUIT

1. Disconnect BCM connector.
2. Check continuity between BCM harness connector M3 terminal 37 (B/W) and key switch harness connector M23 terminal 1 (B/W).

Continuity should exist.

3. Check continuity between BCM harness connector M3 terminal 37 (B/W) and ground.

Continuity should not exist.

OK or NG

OK >> GO TO 6.

NG >> Repair harness or connector.

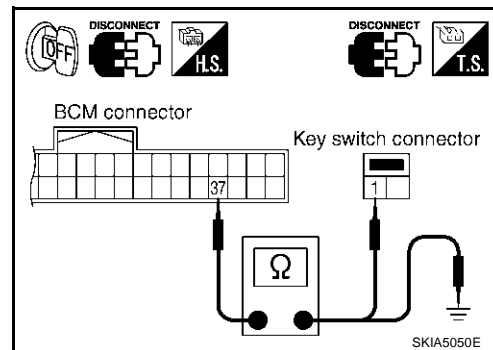

6. CHECK KEY SWITCH POWER SUPPLY CIRCUIT

Check voltage between key switch harness connector M23 terminal 2 (L/R) and ground.

Battery voltage should exist.

OK or NG

OK >> Replace BCM. Refer to [BCS-28, "Removal and Installation of BCM"](#).

NG >> Check harness for open or short between key switch and fuse.

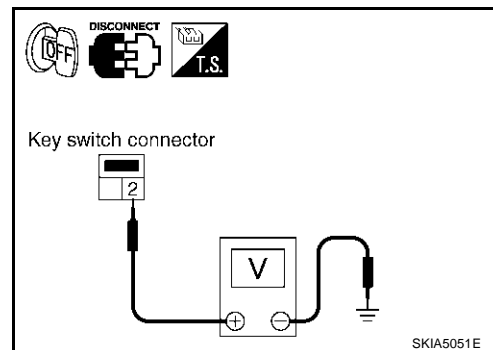

WARNING CHIME

Key Warning Chime Does Not Operate (With Intelligent Key, When Mechanical Key Is Used)

AKS0079U

1. CHECK FUSE

Check if the key switch and ignition knob switch 15A fuse (No. 22, located in the fuse and fusible link box) is blown. Refer to [DI-90, "Wiring Diagram — CHIME —"](#).

Is the fuse blown?

- YES >> Replace fuse. Be sure to repair the cause of malfunction before installing new fuse.
NO >> GO TO 2.

2. CHECK WARNING CHIME OPERATION

Check the chime under conditions in exception of key warning chime (when mechanical key is used) operation.

Does warning chime sound?

- YES >> GO TO 3.
NO >> Go to [DI-99, "All Warnings Are Not Operated"](#) or [DI-100, "Key Warning Chime and Light Warning Chime Does Not Operate \(Seat Belt Warning Chime Does Operate\)"](#).

3. CHECK BCM INPUT SIGNAL

Ⓟ With CONSULT-II

- Select "BCM".
- With "DATA MONITOR" of "BUZZER", confirm "KEY ON SW" when the key is operated.

**When key is inserted to ignition : KEY ON SW ON
key cylinder**

**When key is removed from : KEY ON SW OFF
ignition key cylinder**

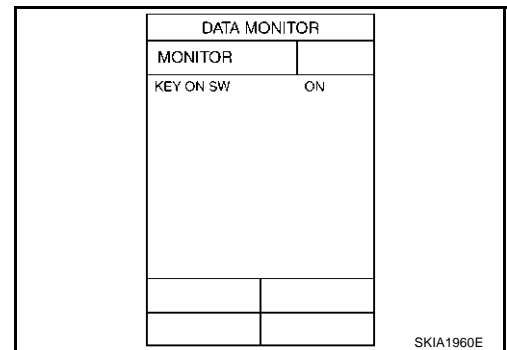

⊗ Without CONSULT-II

Check voltage between BCM harness connector M3 terminal 37 (B/W) and ground.

**When key is inserted to ignition : Approx. 12V
key cylinder**

**When key is removed from : Approx. 0V
ignition key cylinder**

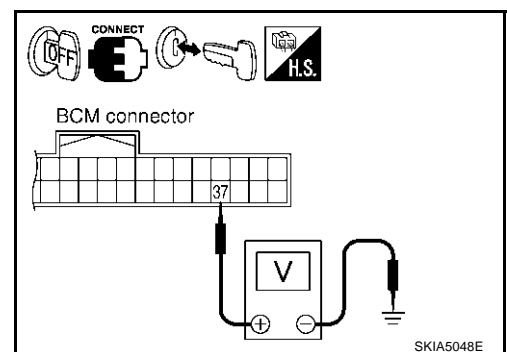

OK or NG

- OK >> Replace BCM. Refer to [BCS-28, "Removal and Installation of BCM"](#).
NG >> GO TO 4.

WARNING CHIME

4. CHECK KEY SWITCH POWER SUPPLY CIRCUIT

1. Disconnect key switch and ignition knob switch.
2. Check voltage between key switch and ignition knob switch harness connector M22 terminal 3 (L/R) and ground.

Battery voltage should exist.

OK or NG

OK >> GO TO 5.

NG >> Check harness for open or short between key switch and ignition knob switch and fuse.

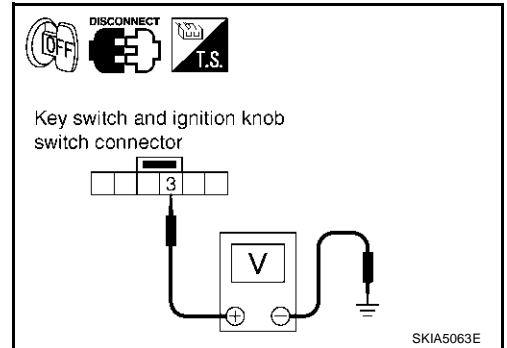

5. CHECK KEY SWITCH

Check continuity between key switch and ignition knob switch connector M22 terminals 3 and 4.

When key is inserted to ignition key cylinder : Continuity should exist

When key is removed from ignition key cylinder : Continuity should not exist.

OK or NG

OK >> GO TO 6.

NG >> Replace key switch and ignition knob switch.

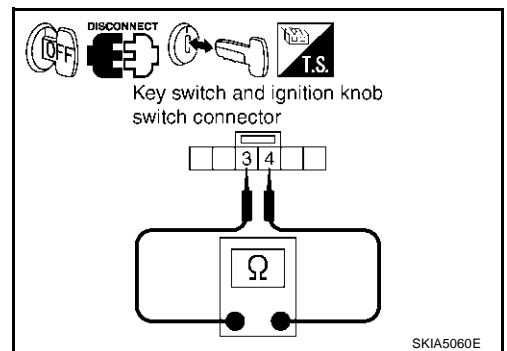

6. CHECK KEY SWITCH CIRCUIT

1. Disconnect BCM connector.
2. Check continuity between BCM harness connector M3 terminal 37 (B/W) and key switch and ignition knob switch harness connector M22 terminal 4 (B/W).

Continuity should exist.

3. Check continuity between BCM harness connector M3 terminal 37 (B/W) and ground.

Continuity should not exist.

OK or NG

OK >> Replace BCM. Refer to [BCS-28, "Removal and Installation of BCM"](#).

NG >> Repair harness or connector.

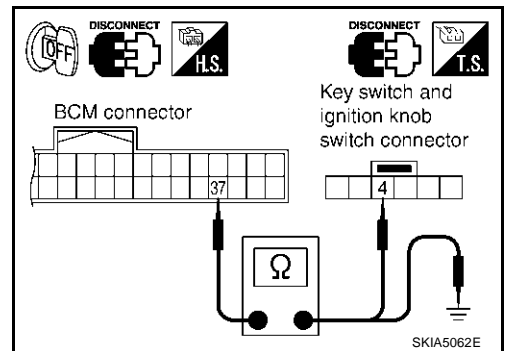

WARNING CHIME

Key Warning Chime Does Not Operate (With Intelligent Key, When Intelligent Key Is Carried With The Driver)

AKS0079V

1. CHECK FUSE

Check if the key switch and ignition knob switch 10A fuse (No. 38, located in the fuse and fusible link box) is blown. Refer to [DI-90, "Wiring Diagram — CHIME —"](#).

Is the fuse blown?

- YES >> Replace fuse. Be sure to repair the cause of malfunction before installing new fuse.
- NO >> GO TO 2.

2. CHECK WARNING CHIME OPERATION

Check the chime under conditions in exception of key warning chime (when Intelligent Key is carried with the driver) operation.

Does warning chime sound?

- YES >> GO TO 2.
- NO >> Go to [DI-99, "All Warnings Are Not Operated"](#) or [DI-100, "Key Warning Chime and Light Warning Chime Does Not Operate \(Seat Belt Warning Chime Does Operate\)"](#).

3. CHECK INTELLIGENT KEY UNIT SELF-DIAGNOSTIC

Perform the Intelligent Key unit self-diagnosis. Refer to [BL-153, "CONSULT-II Functions"](#).

OK or NG

- OK >> GO TO 3.
- NG >> Check the applicable parts.

4. CHECK INTELLIGENT KEY UNIT INPUT SIGNAL

Ⓟ With CONSULT-II

1. Select "INTELLIGENT KEY".
2. With "DATA MONITOR", confirm "PUSH SW" when the ignition knob switch is operated. Refer to [BL-153, "CONSULT-II Functions"](#).

When ignition knob switch is pushed : PUSH SW ON

When ignition knob switch is withdrawn : PUSH SW OFF

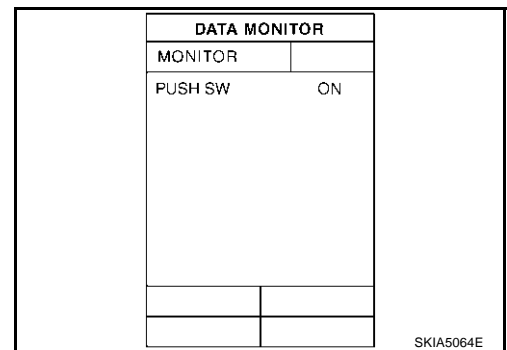

ⓧ Without CONSULT-II

Check voltage between Intelligent Key unit harness connector M34 terminal 27 (L/W) and ground.

When ignition knob switch is pushed : Approx. 12V

When ignition knob switch is withdrawn : Approx. 0V

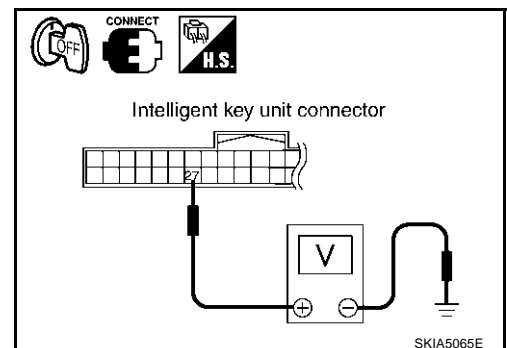

OK or NG

- OK >> Replace Intelligent Key unit. Refer to [BL-183, "Removal and Installation of Intelligent Key Unit"](#).
- NG >> GO TO 4.

WARNING CHIME

5. CHECK IGNITION KNOB SWITCH POWER SUPPLY CIRCUIT

1. Disconnect key switch and ignition knob switch.
2. Check voltage between key switch and ignition knob switch harness connector M22 terminal 1 (L/R) and ground.

Battery voltage should exist.

OK or NG

OK >> GO TO 5.

NG >> Check harness for open or short between key switch and ignition knob switch and fuse.

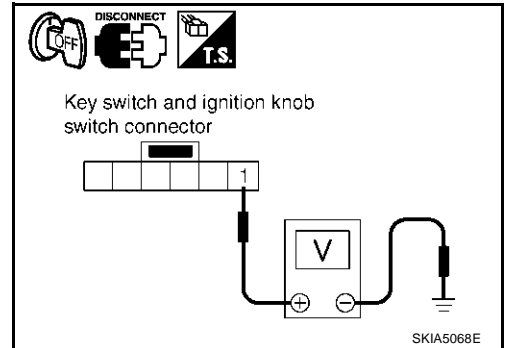

6. CHECK IGNITION KNOB SWITCH

Check continuity between key switch and ignition knob switch connector M22 terminals 1 and 2.

When ignition knob switch is pushed : Continuity should exist.

When ignition knob switch is withdrawn : Continuity should not exist.

OK or NG

OK >> GO TO 6.

NG >> Replace key switch and ignition knob switch.

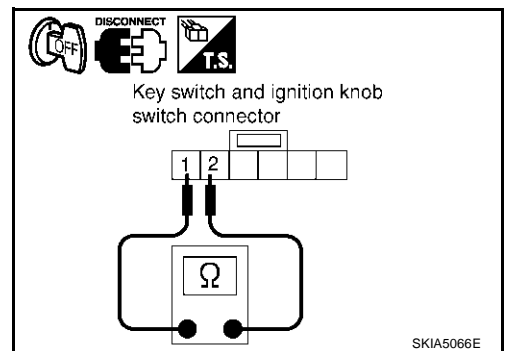

7. CHECK IGNITION KNOB SWITCH CIRCUIT

1. Disconnect Intelligent Key unit connector.
2. Check continuity between Intelligent Key unit harness connector M34 terminal 27 (L/W) and key switch and ignition knob switch harness connector M22 terminal 2 (L/W).

Continuity should exist.

3. Check continuity between Intelligent Key unit harness connector M34 terminal 27 (L/W) and ground.

Continuity should not exist.

OK or NG

OK >> Replace Intelligent Key unit. Refer to [BL-183, "Removal and Installation of Intelligent Key Unit"](#).

NG >> Repair harness or connector.

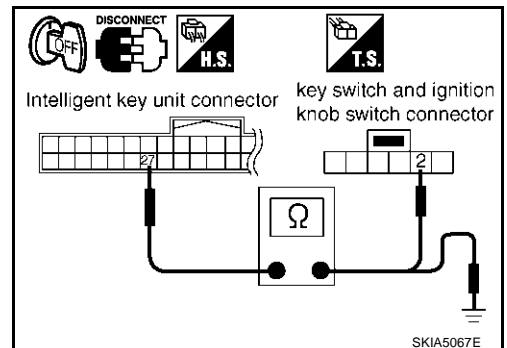

WARNING CHIME

AKS0070J

Light Warning Chime Does Not Operate

1. CHECK WARNING CHIME OPERATION

Check the chime under conditions in exception of light warning chime operation.

Does warning chime sound?

YES >> GO TO 2.

NO >> Go to [DI-99, "All Warnings Are Not Operated"](#) .

2. CHECK BCM INPUT SIGNAL

1. Select "BCM".
2. With "DATA MONITOR" of "BUZZER", confirm "TAIL LAMP SW" when the lighting switch is operated.

Lighting switch (1st position) : TAIL LAMP SW ON

Lighting switch (OFF) : TAIL LAMP SW OFF

OK or NG

OK >> Replace BCM. Refer to [BCS-28, "Removal and Installation of BCM"](#) .

NG >> Check lighting switch. Refer to [LT-182, "Combination Switch Inspection"](#) .

DATA MONITOR	
MONITOR	
TAIL LAMP SW	OFF

SKIA2081E

Seat Belt Warning Chime Does Not Operate

AKS005NX

1. CHECK WARNING CHIME OPERATION

Check the chime under conditions in exception of seat belt warning chime operation.

Does warning chime sound?

YES >> GO TO 2.

NO >> Go to [DI-99, "All Warnings Are Not Operated"](#) .

2. CHECK UNIFIED METER AND A/C AMP. INPUT SIGNAL

1. Select "METAR A/C AMP".
2. With "DATA MONITOR" of "METER A/C AMP", confirm "SEAT BELT W/L" when the seat belt is operated.

When seat belt is fastened : SEAT BELT W/L OFF

When seat belt is unfastened : SEAT BELT W/L ON

OK or NG

OK >> Replace BCM. Refer to [BCS-28, "Removal and Installation of BCM"](#) .

NG >> GO TO 3.

DATA MONITOR	
MONITOR	
SEAT BELT W/L	ON

SKIA6728E

WARNING CHIME

3. CHECK COMBINATION METER INPUT SIGNAL

1. Turn ignition switch ON.
2. Check voltage between combination meter harness connector M20 terminal 9 (LG/R) and ground.

When seat belt is fastened : Approx. 12V

When seat belt is unfastened : Approx. 0V

OK or NG

- OK >> Replace combination meter.
NG >> GO TO 4.

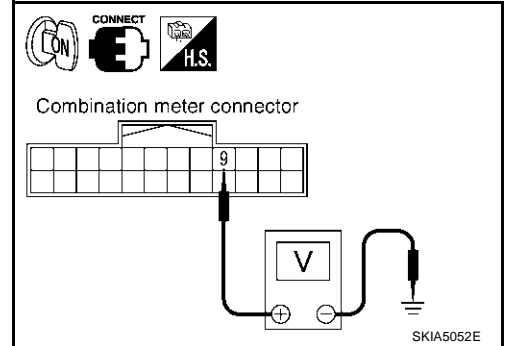

4. CHECK SEAT BELT BUCKLE SWITCH

1. Turn ignition switch OFF.
2. Disconnect seat belt buckle switch (driver side) connector.
3. Check continuity between seat belt buckle switch (driver side) connector B160 terminals 60 and 61A.

When seat belt is fastened : Continuity should not exist.

When seat belt is unfastened : Continuity should exist.

OK or NG

- OK >> GO TO 5.
NG >> Replace seat belt buckle switch (driver side).

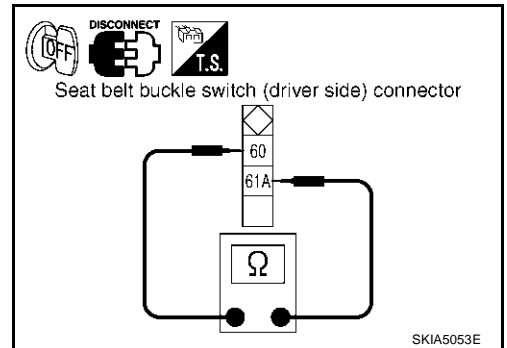

5. CHECK SEAT BELT BUCKLE SWITCH CIRCUIT

1. Disconnect combination meter connector.
2. Check continuity between combination meter harness connector M20 terminal 9 (LG/R) and seat belt buckle switch (driver side) harness connector B160 terminal 60 (R/B).

Continuity should exist.

3. Check harness continuity between combination meter harness connector M20 terminal 9 (LG/R) and ground.

Continuity should not exist.

OK or NG

- OK >> Check seat belt buckle switch (driver side) ground circuit.
NG >> Repair harness or connector.

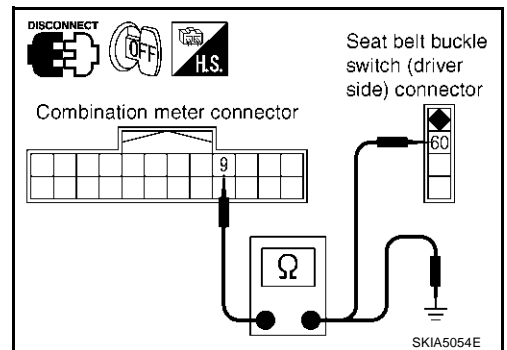

CLOCK

PFP:25820

CLOCK

Wiring Diagram — CLOCK —

AKS0056I

DI-CLOCK-01

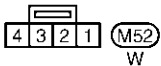
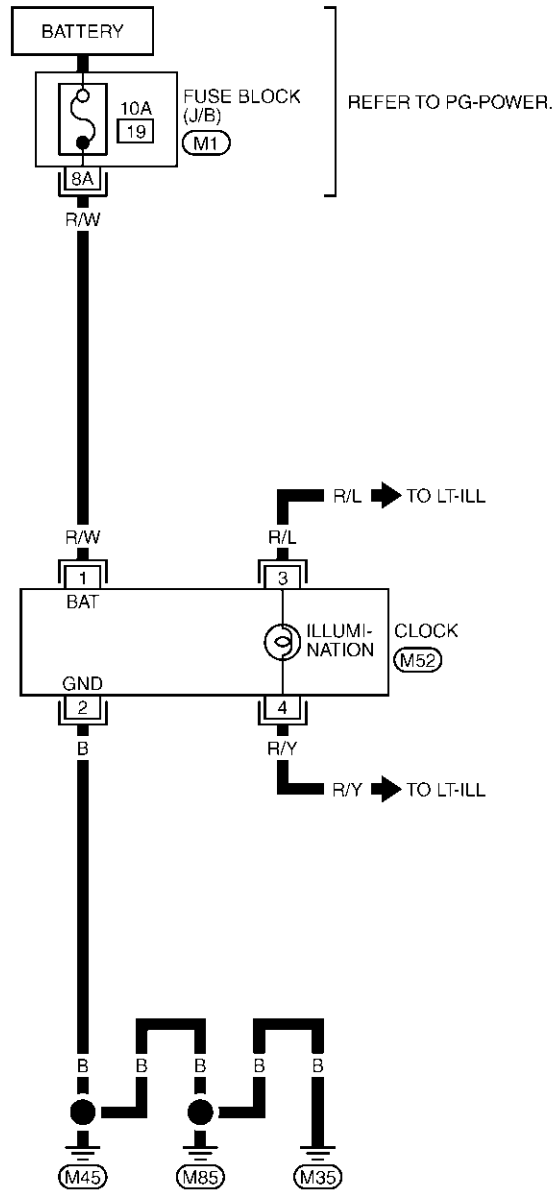

REFER TO THE FOLLOWING.
M1 -FUSE BLOCK-JUNCTION BOX (J/B)

TKWM0699E

CLOCK

Removal and Installation of Clock

AKS007G3

REMOVAL

1. Remove instrument clock finisher. Refer to [IP-12. "\(E\) Instrument Clock Finisher"](#).
2. Remove screws (2), and remove clock from instrument clock finisher.
3. Remove screws (2), and remove bracket.

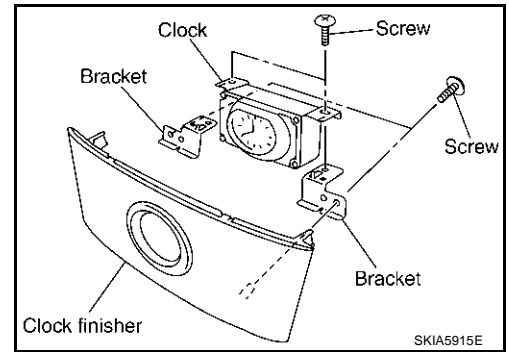

INSTALLATION

Install in the reverse order of removal.

A
B
C
D
E
F
G
H
I
J
DI
L
M

DI

REAR VIEW MONITOR

REAR VIEW MONITOR

PFP:28260

System Description

AKS0068D

- The rear view monitor is equipped to check the rearward of the vehicle with display when A/T selector lever is in reverse position.
- The lines of vehicle sides and the distance from the rear end of the vehicle are provided on display as a guide. It allows the driver to know the distance between the vehicle and a rearward object, and the width of the vehicle much easier.

POWER SUPPLY AND GROUND

Power is supplied at all time

- through 10A fuse [No. 19, located in fuse block (J/B)]
- to rear view camera control unit terminal 1.

When ignition switch is in ACC or ON position, power is supplied

- through 10A fuse [No. 6, located in fuse block (J/B)]
- to rear view camera control unit terminal 2.

When ignition switch is in ON or START position, power is supplied

- through 10A fuse (No. 83, located in IPDM E/R)
- to back-up lamp relay terminals 2 and 3.

Ground is supplied

- to rear view camera control unit terminal 3
- through grounds M35, M45 and M85, and
- to rear view camera terminal 2
- through grounds B15 and B45.

AV COMMUNICATION LINE

Rear view camera control unit is connected to the following units with AV communication line. Each unit transmits/receives data with AV communication line.

- NAVI control unit
- Display
- Display control unit
- A/C and AV switch

REAR VIEW CAMERA OPERATION

When A/T selector lever is reverse position, power is supplied

- through back-up lamp relay terminal 1
- to TCM terminal 7.

Then back-up lamp relay is energized,

- from back-up lamp relay terminal 5
- to rear view camera control unit terminal 4.

Then, rear view camera control unit is sent camera ON signal

- through rear view camera control unit terminal 8
- to rear view camera terminal 1.

An image taken by rear view camera is sent

- through rear view camera terminals 3 and 4
- to rear view camera control unit terminals 10 and 9.

Then an image is sent

- through rear view camera control unit terminals 12 and 14
- to the display terminals 15 and 16.

An image of rear view will be projected on the display.

REAR VIEW MONITOR

Side Distance Guideline

When A/T selector lever is in reverse position, rear view camera control unit is sent rear view camera guideline image

- through rear view camera control unit terminals 12 and 14
- to the display terminals 15 and 16.

Rear view camera guideline will be projected on the display.

Display shows image from rear view camera image and rear view camera guideline.

Component Parts and Harness Connector Location

AKS0068E

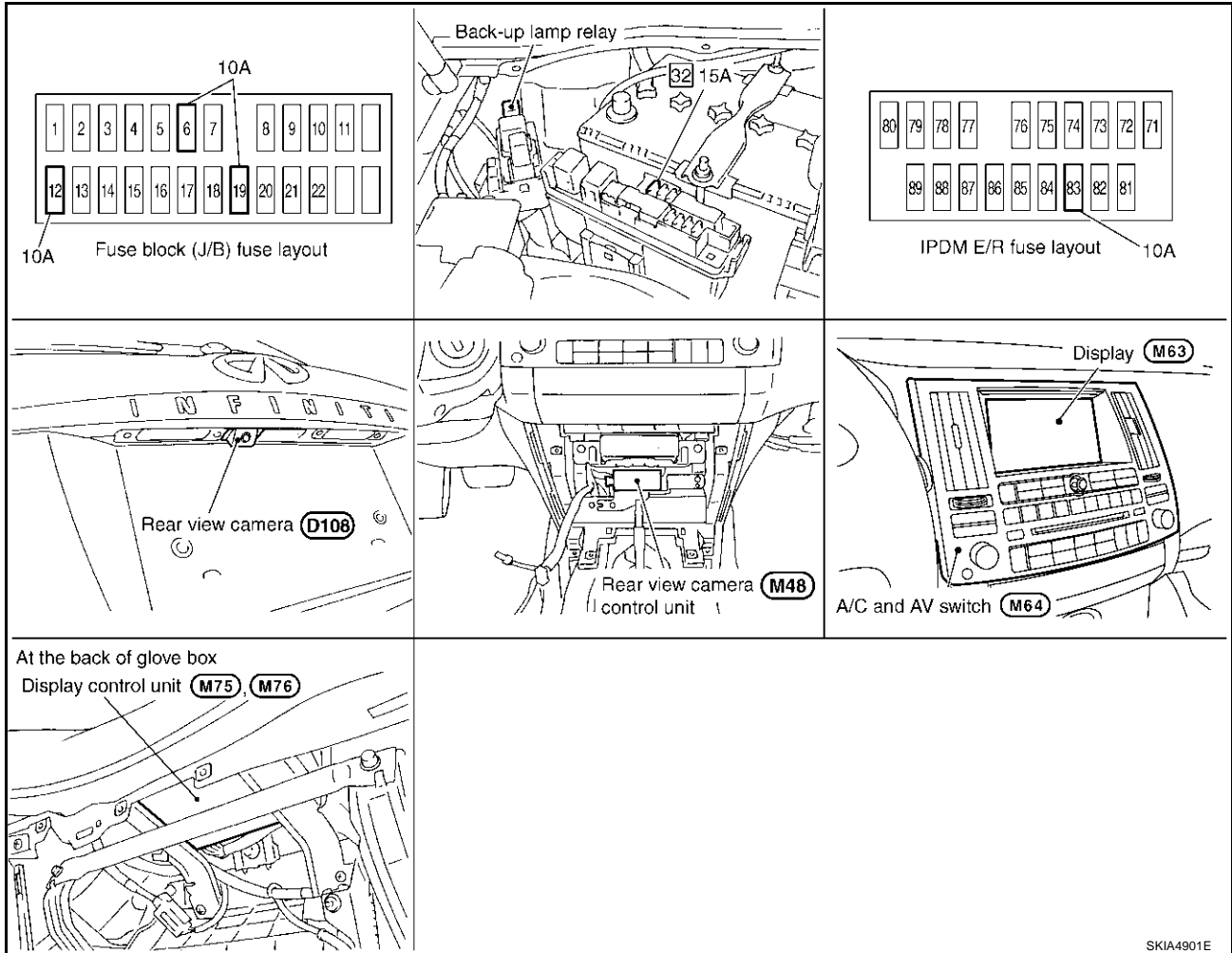

A
B
C
D
E
F
G
H
I
J
DI
L
M

REAR VIEW MONITOR

Schematic

AKS0068F

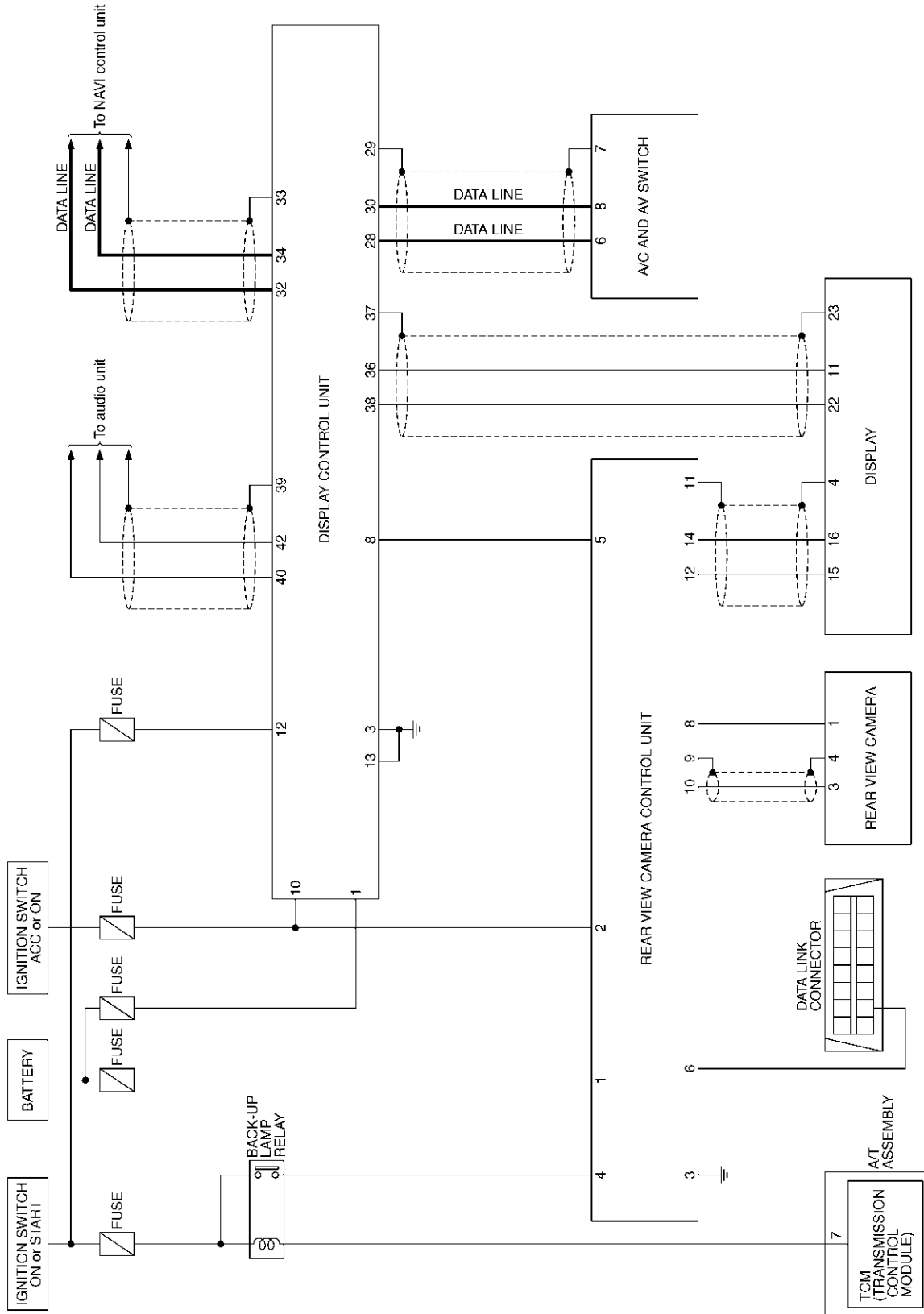

TKWH0243E

REAR VIEW MONITOR

Wiring Diagram — R/VIEW —

AKS0068G

DI-R/VIEW-01

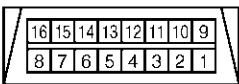
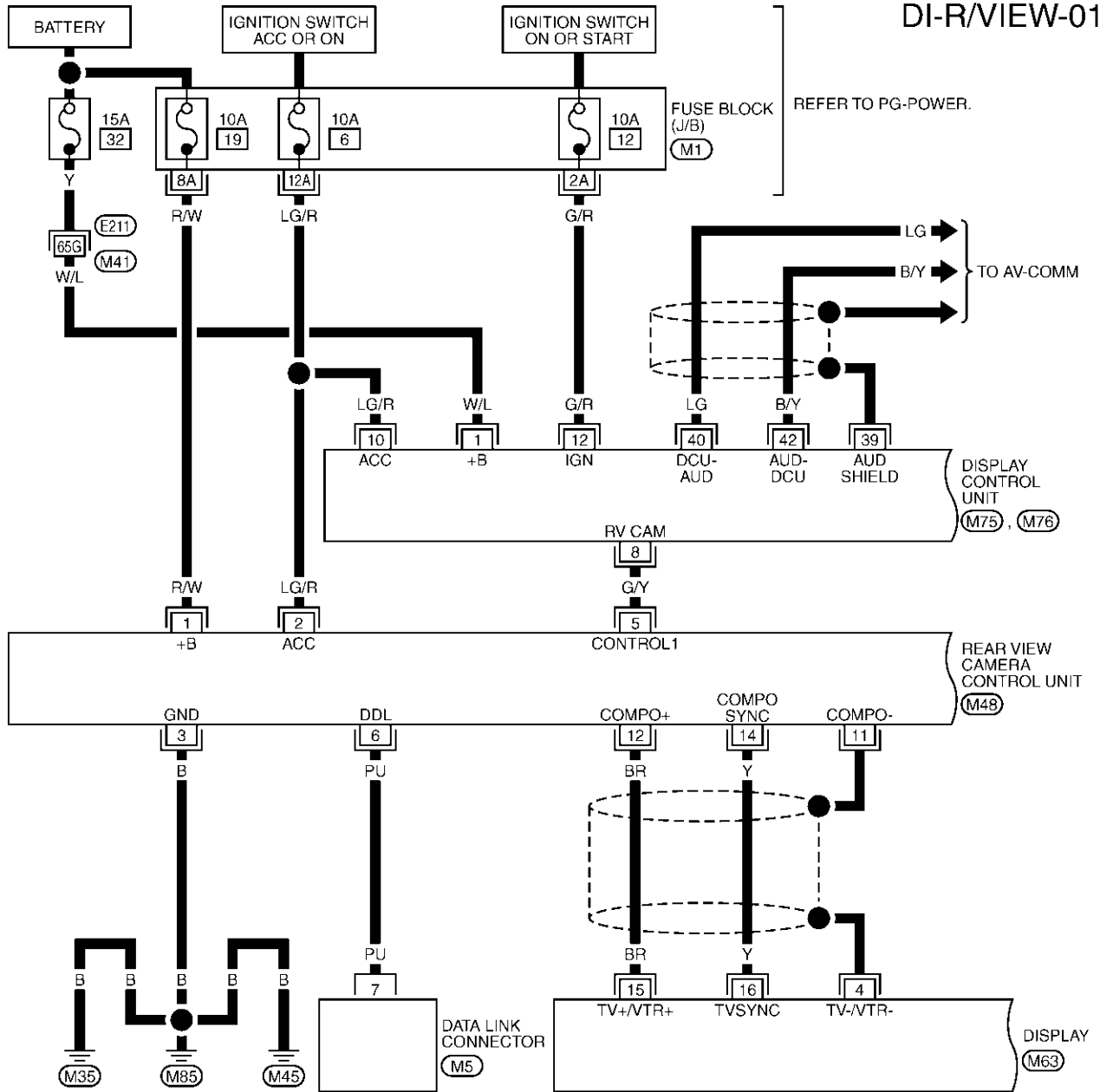

(M5)
W

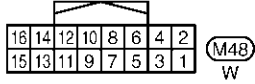

(M48)
W

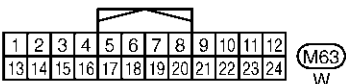

(M63)
W

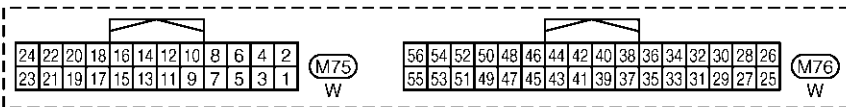

(M75)
W

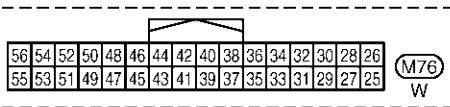

(M76)
W

REFER TO THE FOLLOWING.

(E21) - SUPER MULTIPLE JUNCTION (SMJ)

(M1) - FUSE BLOCK-JUNCTION BOX (J/B)

TKWM0701E

REAR VIEW MONITOR

DI-R/VIEW-02

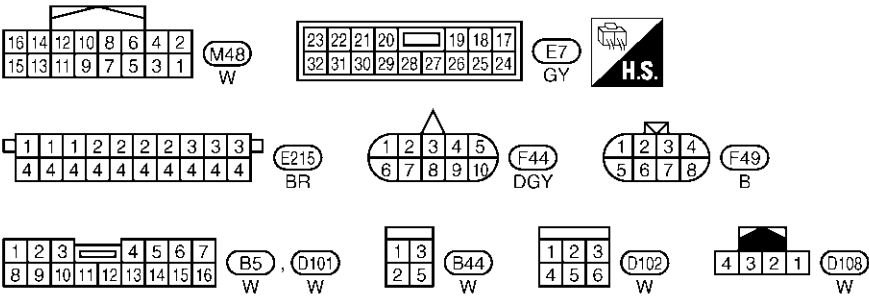
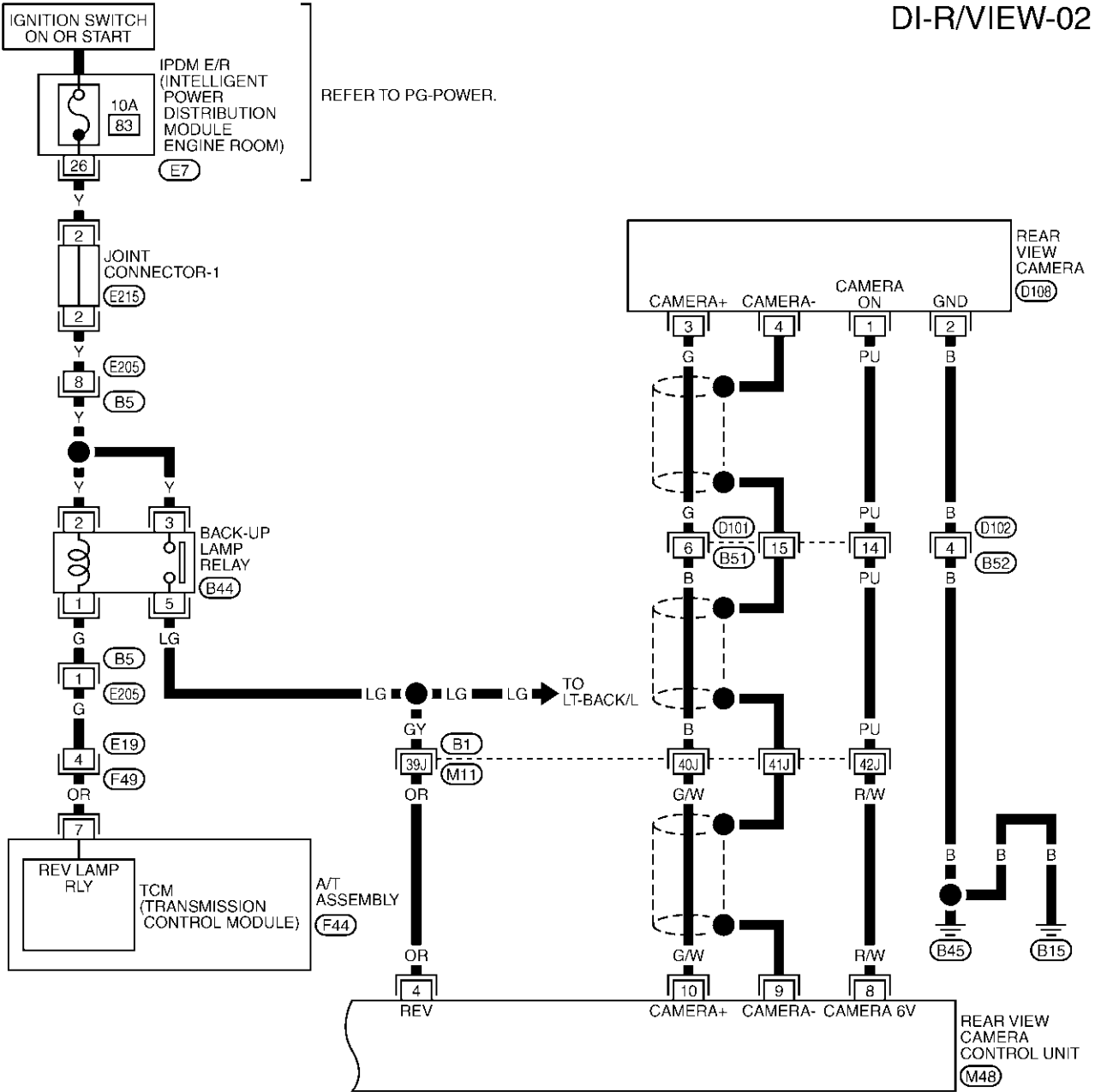

REFER TO THE FOLLOWING.
B1 -SUPER MULTIPLE JUNCTION (SMJ)

TKWM0702E

REAR VIEW MONITOR

DI-R/VIEW-03

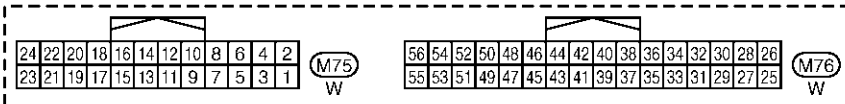
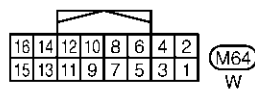
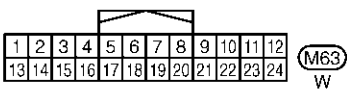
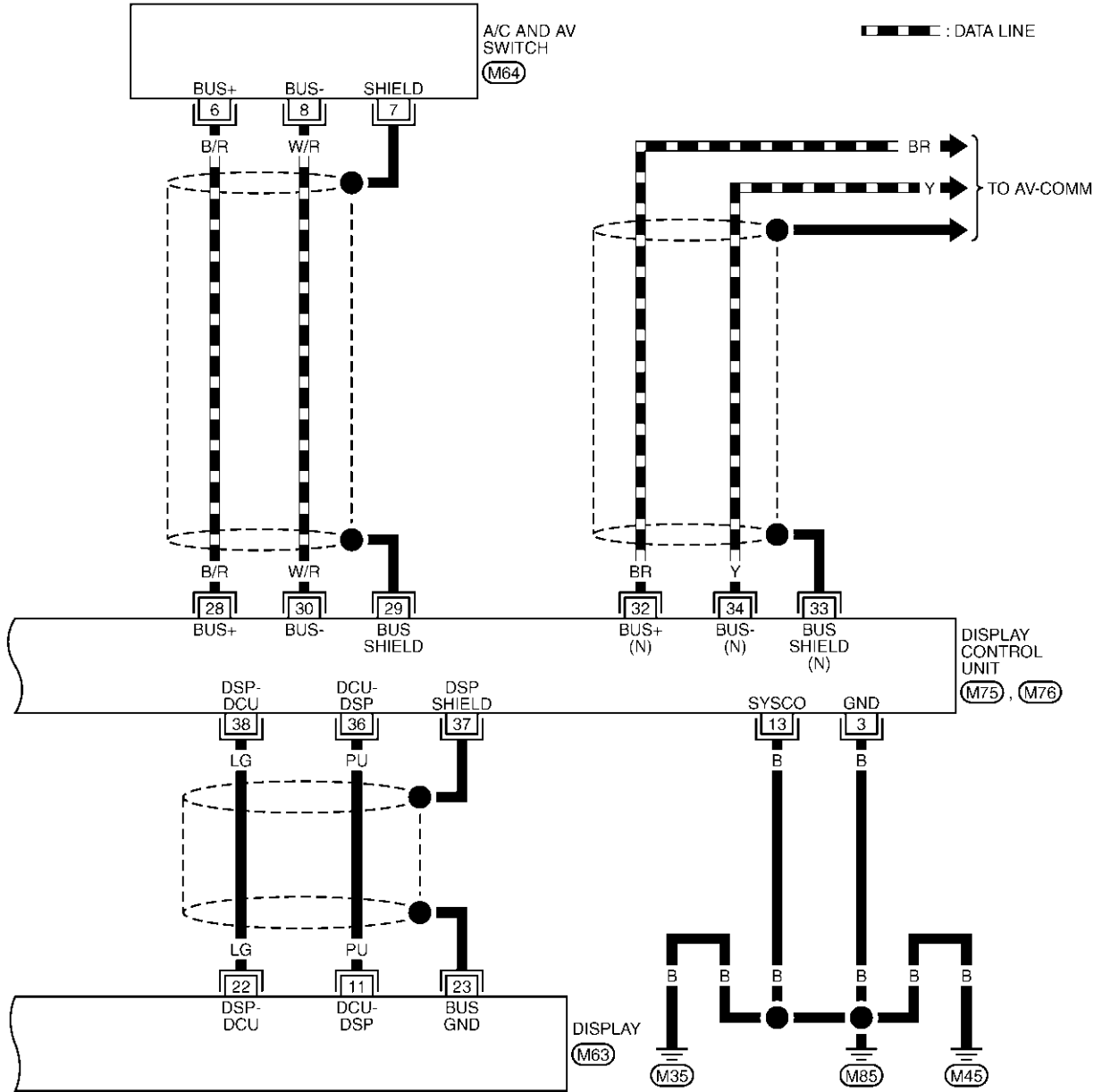

TKWM0703E

REAR VIEW MONITOR

Terminals and Reference Value for Rear View Camera Control Unit

AKS006BH

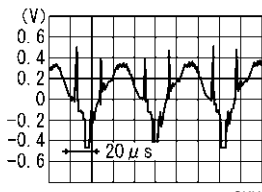
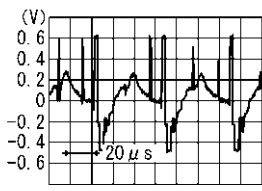
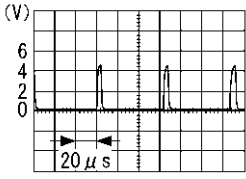
Terminal No.	Wire color	Item	Condition		Reference value
			Ignition switch	Operation	
1	R/W	Battery power supply	OFF	—	Battery voltage
2	LG/R	Ignition switch ACC or ON	ACC	—	Battery voltage
3	B	Ground	ON	—	Approx. 0V
4	OR	Reverse signal input	ON	A/T selector lever R-position	Battery voltage
				A/T selector lever in other than "R" position	Approx. 0V
5	G/Y	CONTROL 1	ON	A/T selector lever R-position	Approx. 0V
				—	Approx. 0V
6	PU	DDL	—	—	—
8	R/W	Camera power output	ON	A/T selector lever R-position	Approx. 6V
9	—	Camera image input (-)	ON	—	Approx. 0V
10	G/W	Camera image input (+)	ON	A/T selector lever R-position	 <p style="text-align: right; font-size: small;">SKIA4894E</p>
11	—	Shield ground	—	—	—
12	BR	Composite image output	ON	A/T selector lever R-position	 <p style="text-align: right; font-size: small;">SKIA4896E</p>
14	Y	Composite image synchronization signal output	ON	A/T selector lever R-position	 <p style="text-align: right; font-size: small;">SKIA5896E</p>

REAR VIEW MONITOR

CONSULT-II Function

AKS007FM

CONSULT-II executes the following functions by combining data reception and command transmission via the communication line from rear view camera control unit.

System part	Check item, diagnosis mode	Description
REARVIEW CAMERA	Work support	It can adjust the side distance guidelines which overlap the rear view monitor image.
	Data monitor	Displays rear view camera control unit input data in real time.
	ECU part number	Displays part number of rear view camera control unit.

CONSULT-II BASIC OPERATION

CAUTION:

If CONSULT-II is used with no connection of CONSULT-II CONVERTER, malfunctions might be detected in self-diagnosis depending on control unit which carry out CAN communication.

1. With the ignition switch OFF, connect "CONSULT-II" and "CONSULT-II CONVERTER" to the data link connector, then turn ignition switch ON.

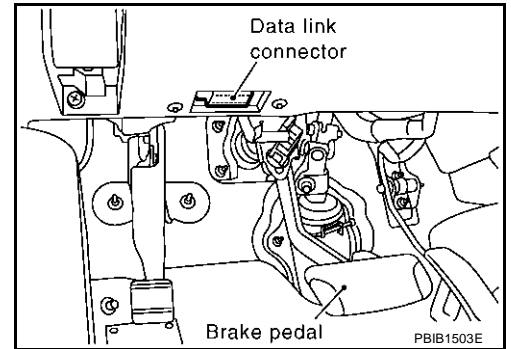

2. Touch "START (NISSAN BASED VHCL)".

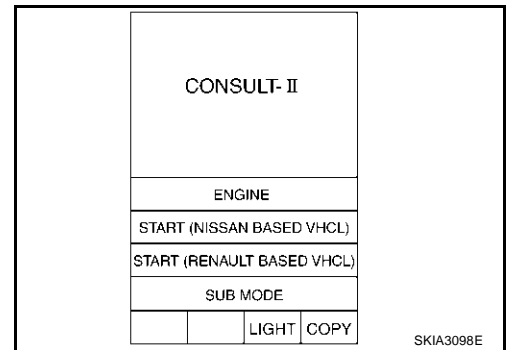

3. Touch "REARVIEW CAMERA" on "SELECT SYSTEM" screen. If "BCM" is not indicated, go to [GI-40, "CONSULT-II Data Link Connector \(DLC\) Circuit"](#).

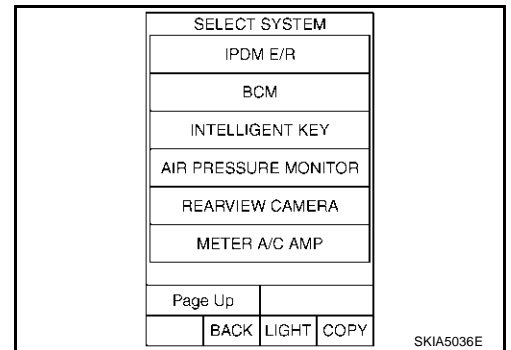

REAR VIEW MONITOR

4. Select "WORK SUPPORT", "DATA MONITOR" or "ECU PART NUMBER".

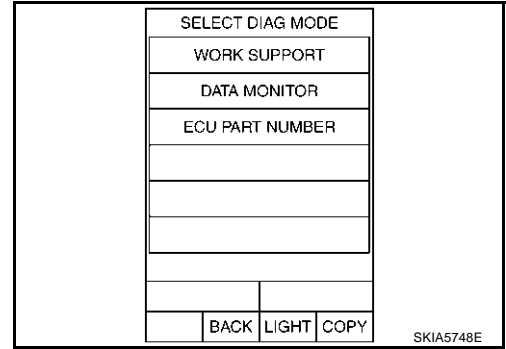

WORK SUPPORT

Operation Procedure

1. Touch "DATA MONITOR" on "SELECT DIAG MODE" screen.
2. Touch either "SELCT GUIDELINE PATTERN" or "ADJ GUIDELINE POSITION" on the "WORK SUPPORT" screen.

SELCT GUIDELINE PATTERN	Side distance guideline is optional from two patterns.
ADJ GUIDELINE POSITION	Side distance guideline is adjustable toward up and down, right and left.

Refer to [DI-121, "SIDE DISTANCE GUIDELINE CORRECTION PROCEDURE"](#) for detail.

DATA MONITOR

Operation Procedure

1. Touch "DATA MONITOR" on "SELECT DIAG MODE" screen.
2. Touch either "ALL SIGNALS" or "SELECTION FROM MENU" on the "DATA MONITOR" screen.

ALL SIGNALS	Monitors all signals.
SELECTION FROM MENU	Selects and monitors individual signal.

3. When "SELECTION FROM MENU" is selected, touch individual items to be monitored. When "ALL SIGNALS" is selected, all items will be monitored.
4. Touch "START".
5. Touch "RECORD" while monitoring, then the status of the monitored item can be recorded. To stop recording, touch "STOP".

Display Item List

Display item [Unit]	ALL SIGNALS	SELECTION FROM MENU	Contents
R POSI SIG [ON/OFF]	X	X	Indicates [ON/OFF] condition of R range position signal input.

REAR VIEW MONITOR

AKS0068L

Side Distance Guideline Correction

This mode is used to modify the side distance guidelines if they are dislocated from the rear view monitor image, because of variations of body/camera mounting conditions.

SIDE DISTANCE GUIDELINE CORRECTION PROCEDURE

1. Create a correction line to modify the screen.
Draw lines on the rearward of the vehicle passing through the following points: 0.2 m (7.87 inch) from both sides of the vehicle, and
 - *1: 0.5 m (1.5 feet)
 - *2: 1 m (3 feet)
 - *3: 2 m (7 feet)
 - *4: 3 m (10 feet)
 and from the rear end of the bumper
2. With the ignition switch OFF, connect "CONSULT-II" and "CONSULT-II CONVERTER" to the data link connector, then turn ignition switch ON. Touch "REARVIEW CAMERA" on CONSULT-II.

CAUTION:

Stop engine for the safety when correcting side distance guideline.

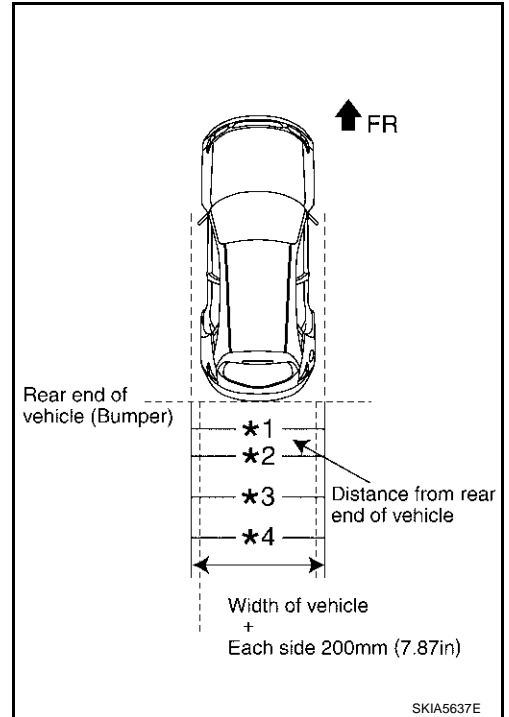

3. Shift the A/T select lever is "R" range position.

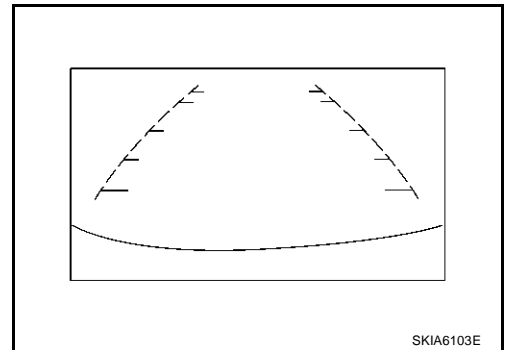

4. Touch "SELCT GUIDELINE PATTERN" on "SELECT WORK ITEM" screen.

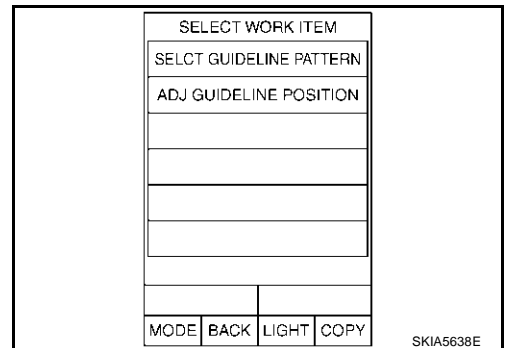

A
B
C
D
E
F
G
H
I
J
DI
L
M

REAR VIEW MONITOR

5. Touch "UP" or "DOWN", and select the guide line, "PATTERN NO. 0" or "PATTERN NO. 1", which is the closest to the corrected line.
6. Touch "SAVE", and confirm the guide line.
7. Touch "END".

SELECT GUIDELINE PATTERN			
CHANGE SHIFT IN R-POSITION			
ADJUST MONITOR			
PATTERN NO.		0	
UP			
SAVE			
MODE	BACK	LIGHT	COPY

SKIA5639E

8. Touch "ADJ GUIDELINE POSITION" on "SELECT WORK ITEM" screen.

SELECT WORK ITEM			
SELECT GUIDELINE PATTERN			
ADJ GUIDELINE POSITION			
MODE	BACK	LIGHT	COPY

SKIA5638E

9. Adjust the guide line touching "X UP", "X DOWN", "Y UP" or "Y DOWN" so that the corrected line can fit the guide line.
10. Touch "SAVE", and confirm the guide line.
11. Touch "END" to finish correcting.

ADJ GUIDELINE POSITION			
CHANGE SHIFT IN R-POSITION			
ADJUST MONITOR			
X VALUE ADJ		0	
Y VALUE ADJ		0	
X DOWN		X UP	
Y DOWN		Y UP	
SAVE			
MODE	BACK	LIGHT	COPY

SKIA5642E

REAR VIEW MONITOR

Power Supply and Ground Circuit Inspection

AKS0068M

1. CHECK FUSE

Make sure the fuses for rear view camera control unit is blown.

Unit	Power source	Fuse No.
Rear view camera control unit	Battery	19
	Ignition switch ACC or ON	6

OK or NG

OK >> GO TO 2.

NG >> If fuse is blown, be sure to eliminate cause of malfunction before installing new fuse. Refer to [PG-3, "POWER SUPPLY ROUTING CIRCUIT"](#) .

2. CHECK POWER SUPPLY CIRCUIT

1. Disconnect rear view camera control unit connector.
2. Check voltage between rear view camera control unit and ground.

Terminals		OFF	ACC
(+)			
Connector	Terminal (Wire color)	(-)	
M48	1 (R/W)	Ground	Battery voltage
	2 (LG/R)	Ground	0V

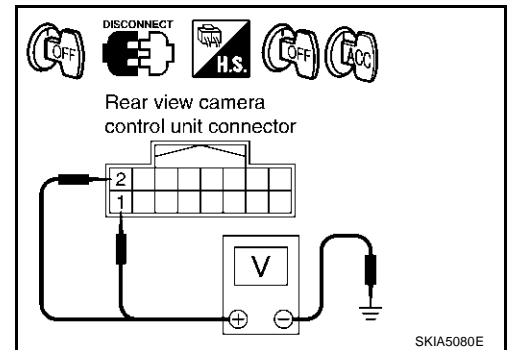

OK or NG

OK >> GO TO 3.

NG >> Check harness for open between rear view camera control unit and fuse.

3. CHECK REAR VIEW CAMERA CONTROL UNIT GROUND CIRCUIT

1. Turn ignition switch OFF.
2. Check continuity between rear view camera control unit harness connector M48 terminal 3 (B) and ground.

Continuity should exist.

OK or NG

OK >> GO TO 4.

NG >> Repair harness or connector.

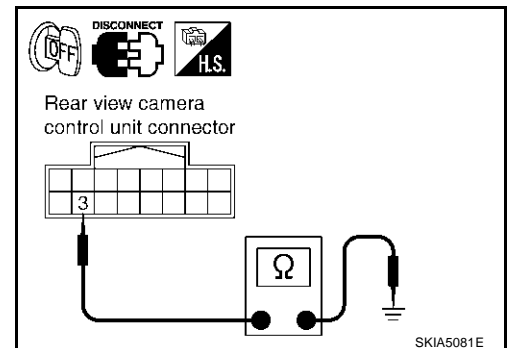

REAR VIEW MONITOR

4. CHECK REAR VIEW CAMERA GROUND CIRCUIT

1. Disconnect rear view camera connector.
2. Check continuity between rear view camera harness connector D108 terminal 2 (B) and ground.

Continuity should exist.

OK or NG

- OK >> INSPECTION END
NG >> Repair harness or connector.

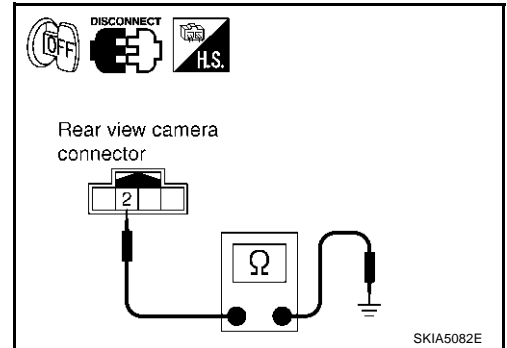

Rear View Is Not Displayed With The A/T Selector Lever In R-position

AKS0068N

1. BACK-UP LAMP INSPECTION

1. Turn ignition switch ON.
2. Shift A/T selector lever to R-position.

Dose back-up lamp illuminate?

- YES >> GO TO 2.
NO >> Check back-up lamp system. Refer to [LT-194, "BACK-UP LAMP"](#) in LT section.

2. CHECK REVERSE POSITION INPUT SIGNAL

With CONSULT-II

Select "DATA MONITOR" of "REARVIEW CAMERA". Operate ignition switch with "R POSI SIG" of "DATA MONITOR" and check operate status.

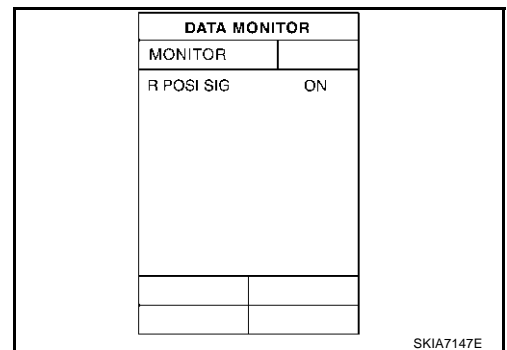

Without CONSULT-II

1. Turn ignition switch OFF.
2. Disconnect rear view camera control unit connector.
3. Turn ignition switch ON.
4. Shift A/T selector lever to R-position.
5. Check voltage between rear view camera control unit harness connector M48 terminal 4 (OR) and ground.

Battery voltage should exist.

OK or NG

- OK >> GO TO 3.
NG >> Check harness for open or short between rear view camera control unit and back-up lamp relay.

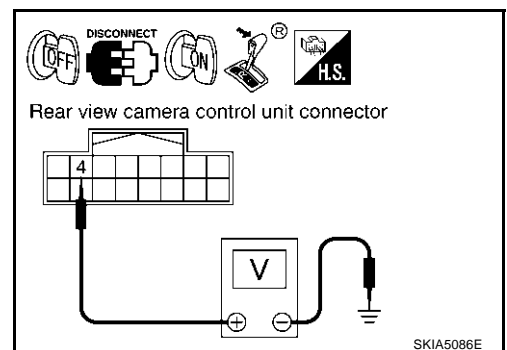

REAR VIEW MONITOR

3. CHECK DISPLAY CONTROL UNIT OUTPUT SIGNAL

1. Turn ignition switch OFF.
2. Disconnect rear view camera control unit connector.
3. Turn ignition switch ON.
4. Check voltage between rear view camera control unit harness connector M48 terminal 5 (G/Y) and ground.

Approx. 5V

OK or NG

- OK >> GO TO 5.
NG >> GO TO 4.

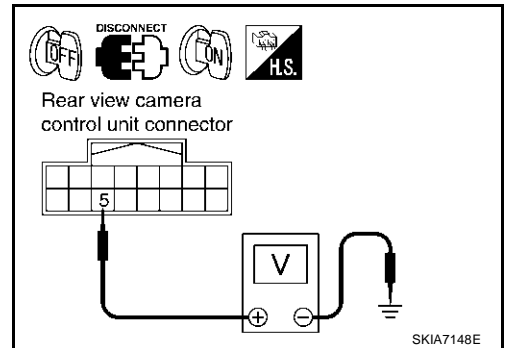

4. CHECK DISPLAY CONTROL UNIT CIRCUIT

1. Turn ignition switch OFF.
2. Disconnect display control unit connector.
3. Check continuity between rear view camera control unit harness connector M48 terminal 5 (G/Y) and display control unit harness connector M75 terminal 8 (G/Y).

Continuity should exist.

4. Check continuity between rear view camera control unit harness connector M48 terminal 5 (G/Y) and ground.

Continuity should not exist.

OK or NG

- OK >> Replace display control unit.
NG >> Repair harness or connector.

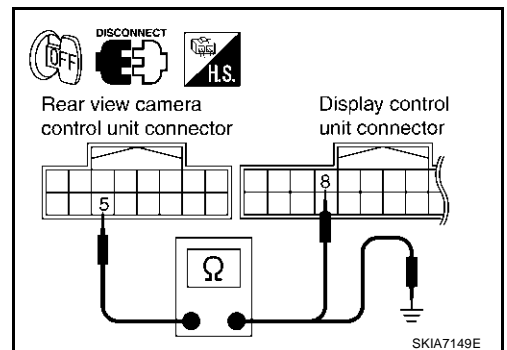

5. CHECK CONTROL 1 SIGNAL

1. Turn ignition switch OFF.
2. Connect rear view camera control unit connector.
3. Shift A/T selector lever to R-position.
4. Check voltage between rear view camera control unit harness connector M48 terminal 5 (G/Y) and ground.

Approx. 0V

OK or NG

- OK >> GO TO 6.
NG >> Replace rear view camera control unit.

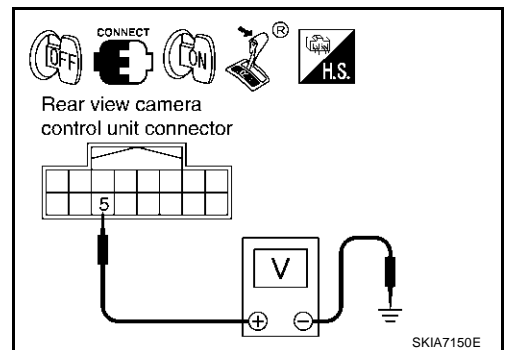

REAR VIEW MONITOR

6. CHECK REAR VIEW CAMERA OPEN CIRCUIT

1. Turn ignition switch OFF.
2. Disconnect rear view camera connector.
3. Check the following.
 - Continuity between rear view camera control unit harness connector M48 terminal 8 (R/W) and rear view camera harness connector D108 terminal 1 (PU)

Continuity should exist.

- Continuity between rear view camera control unit harness connector M48 terminal 9 and rear view camera harness connector D108 terminal 4

Continuity should exist.

- Continuity between rear view camera control unit harness connector M48 terminal 10 (G/W) and rear view camera harness connector D108 terminal 3 (G)

Continuity should exist.

OK or NG

- OK >> GO TO 7.
- NG >> Repair harness or connector.

7. CHECK REAR VIEW CAMERA SHORT CIRCUIT

Check the following.

- Continuity between rear view camera control unit harness connector M48 terminal 8 (R/W) and ground

Continuity should not exist.

- Continuity between rear view camera control unit harness connector M48 terminal 9 and ground

Continuity should not exist.

- Continuity between rear view camera control unit harness connector M48 terminal 10 (G/W) and ground

Continuity should not exist.

OK or NG

- OK >> GO TO 8.
- NG >> Repair harness on connector.

8. CHECK POWER SUPPLY AND GROUND CIRCUIT

Check power supply and ground circuit. Refer to [DI-123, "Power Supply and Ground Circuit Inspection"](#).

OK or NG

- OK >> GO TO 9.
- NG >> Repair or replace power supply and ground circuit.

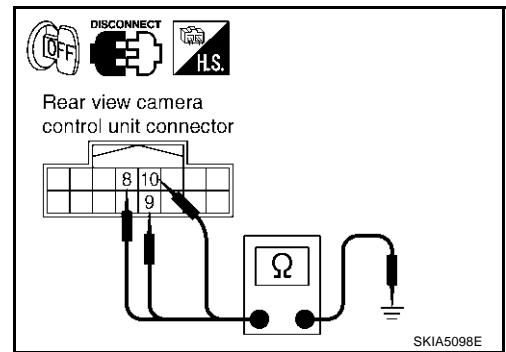
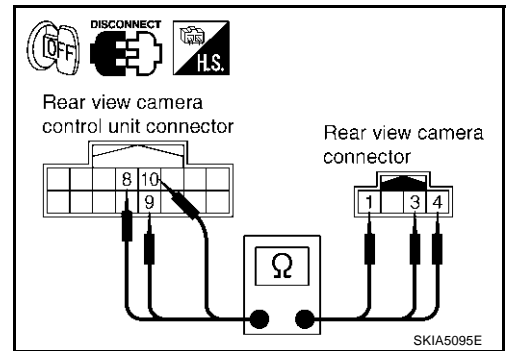

REAR VIEW MONITOR

9. CHECK REAR VIEW CAMERA CONTROL UNIT OUTPUT SIGNAL

1. Connect rear view camera control unit connector.
2. Turn ignition switch ON.
3. Shift A/T selector lever to R-position.
4. Check voltage between rear view camera control unit harness connector M48 terminal 8 (R/W) and ground.

Approx. 6V

OK or NG

- OK >> GO TO 10.
NG >> Replace rear view camera control unit.

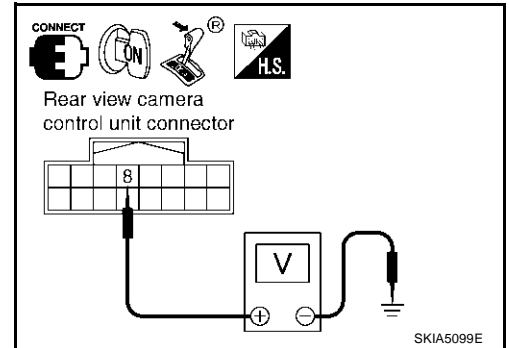

10. CHECK REAR VIEW CAMERA SIGNAL

1. Connect rear view camera connector.
2. Turn ignition switch ON.
3. Shift A/T selector lever to R-position.
4. Check voltage signal between rear view camera control unit harness connector M48 terminal 10 (G/W) and ground.

10 (G/W) - Ground:

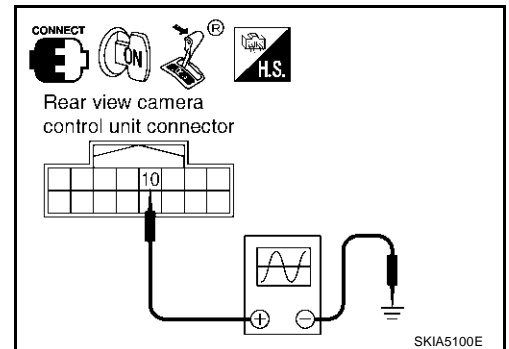
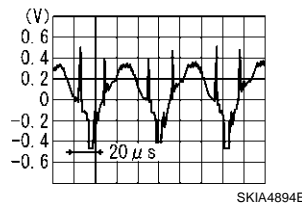

OK or NG

- OK >> GO TO 11.
NG >> Replace rear view camera.

11. CHECK COMPOSITE SIGNAL CIRCUIT

1. Turn ignition switch OFF.
2. Disconnect rear view camera control unit connector and display connector.
3. Check continuity between rear view camera control unit harness connector M48 terminal 12 (BR) and display harness connector M63 terminal 15 (BR).

Continuity should exist.

4. Check continuity between rear view camera control unit harness connector M48 terminal 12 (BR) and ground.

Continuity should not exist.

OK or NG

- OK >> GO TO 12.
NG >> Repair harness or connector.

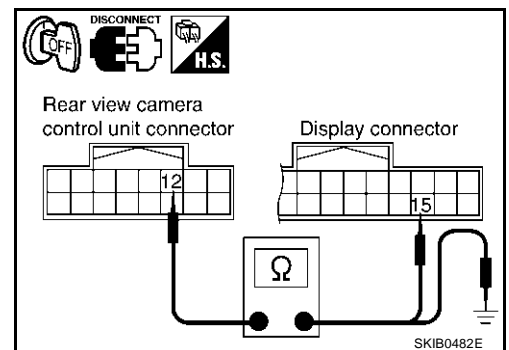

REAR VIEW MONITOR

12. CHECK COMPOSITE SIGNAL GROUND CIRCUIT

1. Check continuity between rear view camera control unit harness connector M48 terminal 11 and display harness connector M63 terminal 4.

Continuity should exist.

2. Check continuity between rear view camera control unit harness connector M48 terminal 11 and ground.

Continuity should not exist.

OK or NG

OK >> GO TO 13.

NG >> Repair harness or connector.

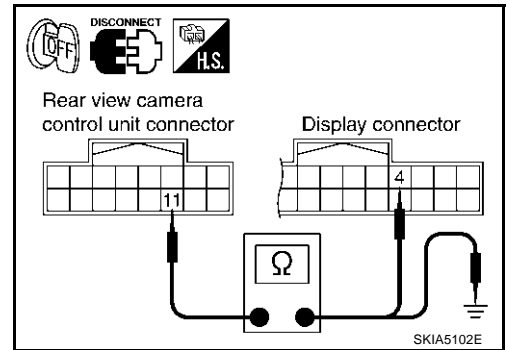

13. CHECK COMPOSITE SIGNAL

1. Connect rear view camera control unit connector and display connector.
2. Turn ignition switch ON.
3. Check voltage signal between rear view camera control unit harness connector M48 terminal 12 (BR) and ground.

12 (BR) - Ground:

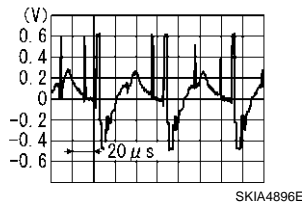

OK or NG

OK >> Replace display.

NG >> Replace rear view camera control unit.

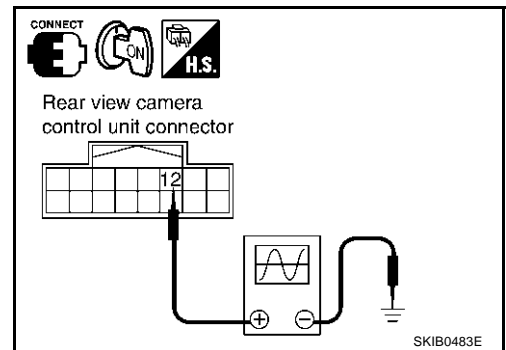

REAR VIEW MONITOR

AKS0068P

The Rear View Image Is Distorted

1. CHECK SYNCHRO SIGNAL OPEN OR SHORT CIRCUIT

1. Turn ignition switch OFF.
2. Disconnect rear view camera control unit connector and display connector.
3. Check continuity between rear view camera control unit harness connector M48 terminal 14 (Y) and display harness connector M63 terminal 16 (Y).

Continuity should exist.

4. Check continuity between rear view camera control unit harness connector M48 terminal 14 (Y) and ground.

Continuity should not exist.

OK or NG

OK >> GO TO 2.

NG >> Repair harness or connector.

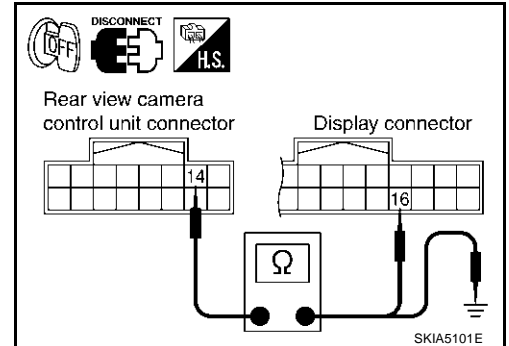

2. CHECK COMPOSITE SIGNAL GROUND CIRCUIT

1. Check continuity between rear view camera control unit harness connector M48 terminal 11 and display harness connector M63 terminal 4.

Continuity should exist.

2. Check continuity between rear view camera control unit harness connector M48 terminal 11 and ground.

Continuity should not exist.

OK or NG

OK >> GO TO 3.

NG >> Repair harness or connector.

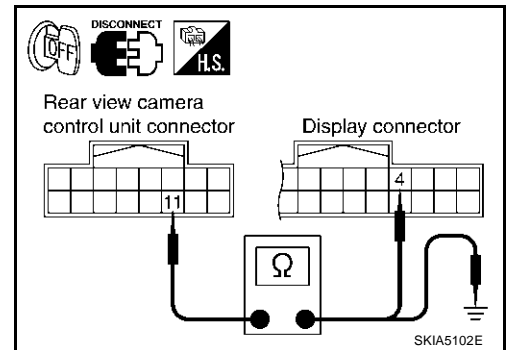

3. CHECK REAR VIEW CONTROL UNIT SYNCHRO SIGNAL

1. Connect rear view camera control unit connector and display connector.
2. Turn ignition switch ON.
3. Check voltage signal between rear view camera control unit harness connector M48 terminal 14 (Y) and ground.

14 (Y) - Ground:

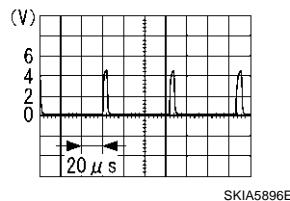

OK or NG

OK >> Replace rear view camera control unit.

NG >> Replace display.

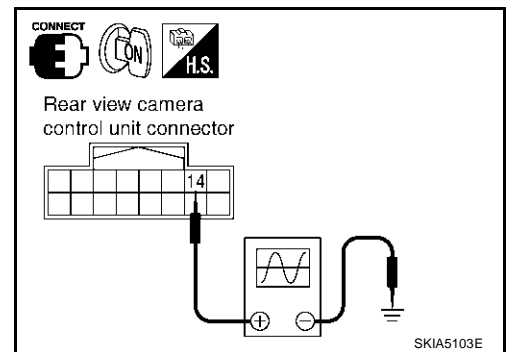

REAR VIEW MONITOR

Removal and Installation of Rear View Camera Control Unit

AKS0068Q

REMOVAL

1. Remove instrument clock finisher and A/T console finisher. Refer to [IP-11, "WORK STEP"](#) .
2. Remove screws (2), and remove rear view camera control unit.

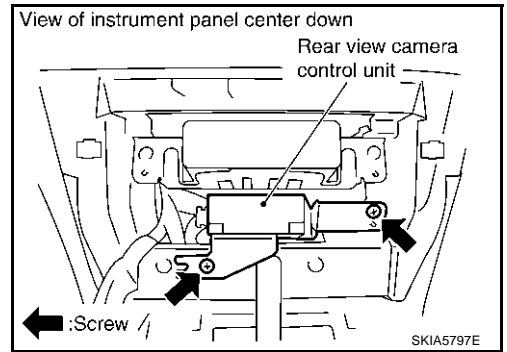

INSTALLATION

Install in the reverse order of removal.

Removal and Installation of Rear View Camera

REMOVAL

1. Remove back door finisher lower. Refer to [EI-46, "Removal and Installation"](#) .
2. Cut off back door module along the line.
3. Remove connector.

AKS0068R

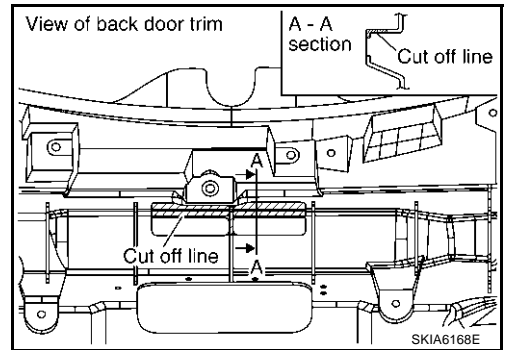

4. Remove screws (2), and remove rear view camera.

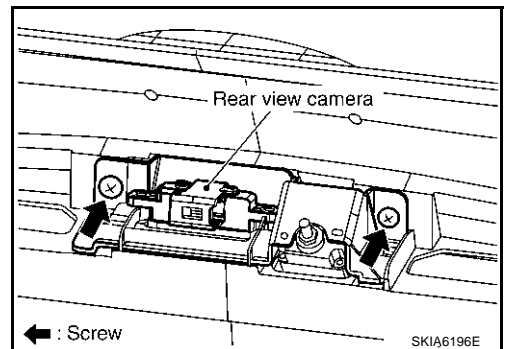

INSTALLATION

Install in the reverse order of removal.